

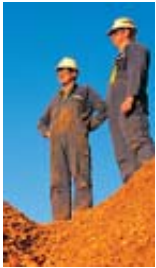

Department of **Consumer  
and Employment Protection**

Resources Safety Division



# Road transport in receptacles of more than 500 L or kg – Dangerous goods safety guidance note T08/08

Details of publications produced by Resources Safety can be obtained by contacting:

Resources Safety  
Department of Consumer and Employment Protection  
Locked Bag 14  
CLOISTERS SQUARE WA 6850

Telephone: +61 8 9358 8002 (general queries)  
+61 8 9358 8154 (publication orders)

NRS: 13 36 77

Facsimile: +61 8 9358 8000

Email: ResourcesSafety@docep.wa.gov.au (general queries)  
RSDcomms@docep.wa.gov.au (publication orders)

Web: [www.docep.wa.gov.au/ResourcesSafety](http://www.docep.wa.gov.au/ResourcesSafety)

# Contents

<b>Introduction</b> .....	<b>4</b>
<b>Duties</b> .....	<b>4</b>
<b>General obligations</b> .....	<b>5</b>
Vehicle licensing.....	5
Driver licensing.....	5
Design approval .....	5
Maintenance checks.....	6
Insurance.....	6
Documentation .....	6
Transport and emergency procedures.....	7
Vehicle placarding.....	8
Personal protective and safety equipment.....	8
Segregation .....	8
Attachment systems.....	8
<b>Specific obligations</b> .....	<b>9</b>
Spill protection.....	9
Tank-to-cabin clearance.....	9
Exhaust .....	9
Vehicle stability.....	9
Rear bumper .....	10
Road clearance .....	11
Vehicle rollover protection.....	11
Tail shaft.....	11
Battery .....	11
Wiring .....	11
Drive-away protection.....	12
Pumps .....	12
Hose assemblies.....	12
<b>Additional obligations for flammable dangerous goods</b> .....	<b>12</b>
Cabling .....	12
Battery isolation switch.....	13
Vehicle rollover device .....	13
Fill and discharge lights.....	13
Hazardous locations.....	13
Sparking equipment .....	13
<b>Further information</b> .....	<b>13</b>

# Introduction

When dangerous goods are transported by road in receptacles with a capacity greater than 500 litres or net mass greater than 500 kilograms (> 500 L/kg), certain duties and obligations apply under the Dangerous Goods Safety (Road and Rail Transport of Non-explosives) Regulations 2007 and the seventh edition of the *Australian Code for the Transport of Dangerous Goods by Road and Rail* (ADG7) to ensure the goods are transported safely.

This guidance note assists those transporting dangerous goods on Western Australian roads to comply with the relevant safety requirements for:

- road tank vehicles;
- conventional vehicles that are provided with transportable tanks; and
- tank containers or intermediate bulk containers (IBCs) that are filled or emptied while on the vehicle.

It does not apply to transport:

- of explosives and infectious or radioactive substances;
- on roads excluded from public access;
- of retail distribution loads that comply fully with ADG7 chapter 7.3; and
- where the aggregate quantity of the dangerous goods in the load is less than 25 per cent of the placard load limit, and the dangerous goods are being transported by someone who is not in the dangerous goods transport business.

If your receptacle has a capacity or net mass of 500 L/kg or less, refer to Dangerous Goods Safety Guidance Note T07.

*Note: As a transitional measure, either ADG6 or ADG7 may be followed until 31 December 2009. ADG7 takes full effect from 1 January 2010.*

## Duties

Anyone involved in dangerous goods transport tasks has a duty of care to ensure that the goods are transported in a safe manner. In addition to the vehicle requirements, everyone involved in the transport operation must be sufficiently trained and competent to undertake tasks safely.

Contracting or subcontracting tasks related to the transport of dangerous goods does not relieve consignors and prime contractors of their responsibility to ensure that the dangerous goods are transported safely and in accordance with the legislative requirements. If you are contracting out work relating to the transport of dangerous goods, you need to ensure that:

- contractors meet the requirements of the legislation; and
- all persons employed by contractors are sufficiently trained and competent to undertake all tasks safely.

All responsible parties involved in the transport of dangerous goods must comply with procedures for breakdowns, general precautions and recommended routes for transport of dangerous goods in accordance with chapter 13 of ADG7.

# General obligations

## Vehicle licensing

- Road vehicles transporting dangerous goods in receptacles > 500 L/kg must be licensed. Licensing information is available from the Resources Safety website.
- A copy of the dangerous goods vehicle licence should accompany the dangerous goods vehicle.
- Prime movers and dollies do not require a dangerous goods vehicle licence as they are not considered to be vehicles that transport dangerous goods.

## Driver licensing

- A person who drives a vehicle on which dangerous goods are carried in receptacles with individual capacities > 500 L/kg requires a dangerous goods driver licence. Licensing information is available from the Resources Safety website.
- The licence must be carried with the person while driving a vehicle transporting dangerous goods.

*Note: Drivers and vehicles transporting IBCs do not require licensing if the total capacity on the vehicle is no more than 3,000 litres and they are not filled or emptied on the vehicle.*

## Design approval

Tanks and receptacles > 500 L/kg used to transport dangerous goods must be approved by a 'Competent Authority'. In Western Australia, this is Resources Safety for Classes 1 to 5, 6.1 and 8 and some Class 9 dangerous goods.

## Tank approval

- Tanks must be built in accordance with an 'approved' design (e.g. for new tanks, Australian Standard AS 2809:2008 *Road tank vehicles for dangerous goods*). Contact Resources Safety regarding the application for approval of a design. Sufficient detail must be provided to demonstrate compliance with the applicable standards for the tank and vehicle as required by ADG7.

*Note: Depending on the adequacy of the supporting documentation, the approval process may be involved and lengthy.*

- Third-party certification by a recognised body may be accepted as evidence of compliance with a particular standard.
- A compliance plate must be fixed to the tank and include specified information and other requirements as stated in ADG7 chapter 6.9.

## IBC approval

- IBCs must be approved by a Competent Authority and built in accordance with ADG7. Contact Resources Safety regarding the application for approval of a design. Sufficient detail must be provided to demonstrate compliance with ADG7.

*Note: Depending on the adequacy of the supporting documentation, the approval process may be involved and lengthy.*

## Maintenance checks

### Tank maintenance checks

- Tanks must have a maintenance plate fixed displaying the dates of:
  - maintenance checks (every 2.5 years); and
  - pressure tests (in accordance with ADG7 and every five years as specified in the edition of AS 2809 current at the time the tank was put into service).

### IBC maintenance checks

- ADG7 details the maintenance checks that should be followed for IBCs.
- Record the results of initial and periodic testing of IBCs in test reports, which are kept by the owner of the IBC until at least the date of the next inspection.
- Metal, rigid plastic and composite IBCs must be inspected to the satisfaction of the Competent Authority before they are put into service (including after remanufacture), and thereafter at intervals not exceeding five years, as specified in ADG7 section 6.5.4.

## Insurance

- Vehicles used to transport placard loads of dangerous goods must have insurance cover of at least \$5,000,000 per event covering:
  - property damage, personal injury and other damage arising out of any fire, explosion, leakage or spillage of dangerous goods in, on or from the vehicle or a container transported on the vehicle; and
  - costs incurred by or on behalf of a government authority in a clean-up operation.

## Documentation

### Emergency information

- The latest edition of Australian Standard Handbook HB76 *Dangerous Goods – Initial Emergency Response Guide* (SAA/SNZ HB76) or emergency procedure guides covering the dangerous goods being transported and vehicle fire must be carried in the emergency holder in a prominent position in the driver's compartment — preferably on the inside of the driver's door.

*Note: Any vehicle carrying a placard load of dangerous goods must be fitted with an emergency information holder marked with the words 'Emergency procedure guides' or 'Emergency information' in red letters at least 10 mm high on a white background. The holder must be secured on the inside of a door of the cabin in a conspicuous position. If this is not possible, it may be positioned adjacent to the door.*

## Transport documentation

- Transport documentation for all dangerous goods loaded on the vehicle must be carried in the emergency information holder. Refer to Dangerous Goods Safety Guidance Note T02 for further information.

## Transport and emergency procedures

### Transport procedures

- The use of a vehicle to carry dangerous goods in receptacles of capacity > 500 L/kg, places responsibilities on all parties involved, including an obligation to:
  - ensure compliance with statutory requirements;
  - maintain the vehicle and associated equipment to a satisfactory standard;
  - provide certain information to other affected parties;
  - adequately document each load; and
  - take all reasonable safety precautions to protect the public.

### Emergency procedures

- Consignors of dangerous goods must ensure that:
  - expert information and advice on the hazardous properties of the dangerous goods being consigned are available at all times in the event of an emergency; and
  - appropriate neutralising and absorbing agents can be made available if required.
- The prime contractor is responsible for ensuring an emergency plan is available for the transport of placard loads of dangerous goods.

### Emergency responders

- From 1 March 2009, a prime contractor transporting a placard load of dangerous goods in Western Australia must either:
  - be an approved emergency responder; or
  - have a contract with an approved emergency responder.

The role of an emergency responder is to control the clean up response that may result from an incident involving a road vehicle transporting the goods.

## Vehicle placarding

- Vehicles transporting dangerous goods in receptacles > 500 L/kg must be placarded in accordance with ADG7 chapter 5. As a guide, the following points should be noted:
  - **Dangerous goods with same UN number in receptacles > 500 L/kg**  
A class or division label and subsidiary risk label, if applicable, and emergency information panels are required.
  - **Dangerous goods with different UN numbers in receptacles > 500 L/kg**  
A class or division label for each class or division of dangerous goods is required and, if applicable, subsidiary risk label, mixed class label or both. If the goods comprise a mixed load of refined petroleum products then mixed load (refined petroleum product) emergency information panels are required. If the goods are not a mixed load of refined petroleum products then multi-load emergency information panels are required.
  - **Dangerous goods of same class and sub-risk, if applicable, in receptacles > 500 L/kg and ≤ 500 L/kg**  
Emergency information panels and labels are required as if there were only dangerous goods in receptacles > 500 L/kg. Class or division labels and subsidiary risk labels, if applicable, are also required except where the subsidiary risk is already indicated by a class or division label.
  - **Dangerous goods of different class and sub-risk, if applicable, in receptacles > 500 L/kg and ≤ 500 L/kg**  
Emergency information panels and mixed class labels may be used.
- Class labels must be at least 250 mm x 250 mm.
- Class or division labels or mixed class labels must be positioned at the front of the vehicle, with an emergency information panel on each side of all trailers loaded with dangerous goods in receptacles > 500 L/kg and to the rear of the vehicle.

## Personal protective and safety equipment

- Refer to Dangerous Goods Safety Guidance Note T03 for further information

## Segregation

- Incompatible dangerous goods must be segregated in accordance with ADG7 part 9.

## Attachment systems

- A transport unit on a vehicle must be securely attached to the vehicle in accordance with ADG7 chapter 8.2. The attachment device must be designed to restrain twice the gross mass of the transport unit when fully laden.
- Portable tanks and freight containers must be secured on a vehicle using either four engaged twist locks or another equally effective method.

*Note: Chains are not usually considered to be suitable.*

# Specific obligations

## Spill protection

- Protect valves, safety relief devices, fittings and accessories from the risk of damage in the event of an accident. They should not protrude beyond the width of the vehicle as damage can lead to product spillage.
- Shields or diverters must be provided where potential spillage or leakage could create a hazard. The effect of corrosives on safety components (e.g. brake piping), possibility of flammable liquid spillage onto hot engine or exhaust components and likely movement or spray of spillage should be considered.

## Tank-to-cabin clearance

- Under no conditions may the distance between the cab and tank be less than 75 mm.

## Exhaust system

- Direct the vehicle exhaust system discharge away from the tank or any of its openings. For vehicles transporting flammable liquids, the exhaust system should be appropriately shrouded.

## Vehicle stability

- The maximum stability angle ('A' in Figure 1) is:
  - 62° for a road tank vehicle for other than Class 2 dangerous goods;
  - 64° for a rigid road tank vehicles for Class 2 dangerous goods (gases), designed in accordance with the edition of AS 2809.3 or AS 2809.6 current at the time the tank was put into service; and
  - 64° for a portable tank being transported on a road vehicle.

*Note: Figure 2 shows a typical example of how to determine the centroid height (shown in Figure 1), which is the height of the centre of mass of a fully laden tanker. Tankers with non-uniform barrels require special consideration.*

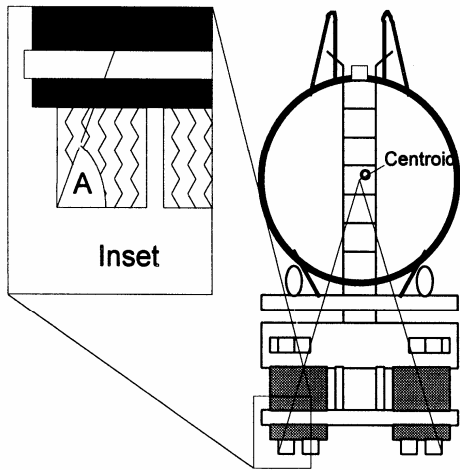

**Figure 1** Measurement of vehicle stability angle

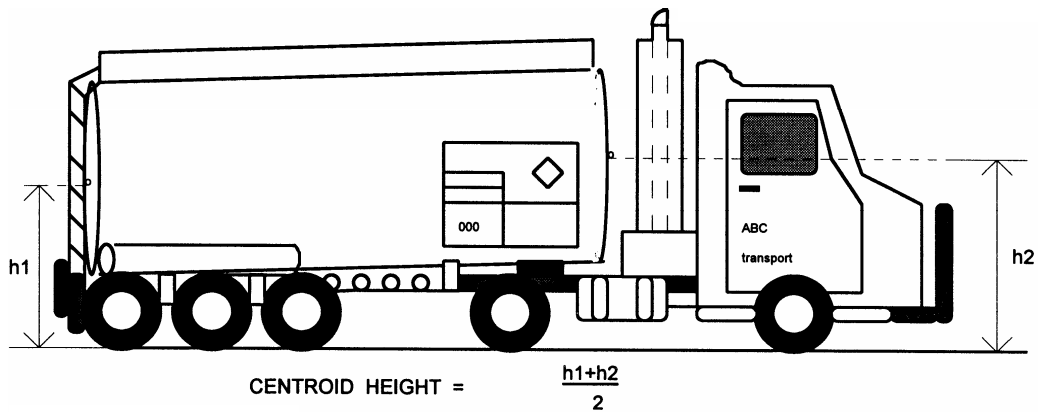

**Figure 2** Measurement of centroid height  
*Note: Measurements made with vehicle fully laden*

## Rear bumper

- The rear bumper must:
  - be structurally sound;
  - be attached only to the chassis or subframe of the vehicle;
  - be 150 mm clear of the bulk container or the rearmost vertical projection of the tank or any component or fitting (Figure 3); and
  - extend at least the full width of the tank.

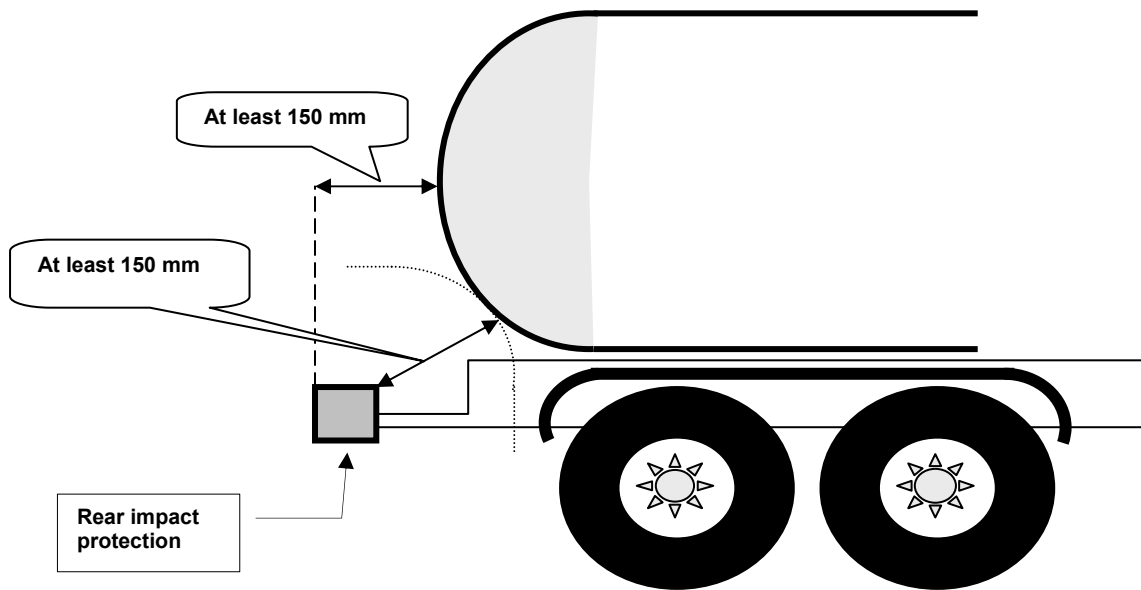

**Figure 3** Location of rear bumper in relation to tank

## Road clearance

- When the vehicle is unladen, the ground clearance for tank components and protection devices must not be less than 250 mm within 1 m of any axle, or 350 mm for any other location.
- Tank filling and discharge connections that are rigidly attached to the tank must not extend lower than 40 mm below the plane through the centre-line of the axles.

## Vehicle rollover protection

- For roll-over protection requirements, refer to the edition of AS 2809 current at the time the tank was put into service.

## Tail shaft

- The bulk container and any components carrying dangerous goods must be protected from contact with the tail shaft mechanism in the event of it flailing.

## Battery

- The vehicle battery must be firmly secured, easily accessible and have a substantial electrically insulated, acid-resistant lid.

## Wiring

- Normal automotive wiring practice is adequate for non-flammable dangerous goods vehicles provided potential hazards resulting from leaks and spillage have been

considered. The wiring requirements for vehicles transporting flammable dangerous goods are detailed in *Additional obligations for flammable dangerous goods*.

## Drive-away protection

- The road tank vehicle needs to be immobilised whenever any there is a transfer to or from it.

*Note: Wheel chocks or other external wheel-locking devices must not be used as the primary method of immobilisation.*

- The method of immobilisation must be such that it cannot operate while the road tank vehicle is being normally driven.

## Pumps

- Pumps for handling the cargo of a road tank vehicle must be fit-for-purpose.

## Hose assemblies

- Hose assemblies used for transferring dangerous goods must be chemically compatible with the dangerous goods to be transferred. They must comply and be tested in accordance with ADG7 and relevant Australian Standards.
- Do not use a hose assembly if visual inspection or hydrostatic testing indicates it is damaged or leaking.

# Additional obligations for flammable dangerous goods

## Cabling

- Cables outside and to the rear of the cabin must be protected:
  - in accordance with the editions of Australian Standards AS/NZS 2053.1 *Conduits and fittings for electrical installations – General requirements*, AS/NZS 2053.2 *Conduits and fittings for electrical installations – Rigid plain conduits and fittings of insulating material* and AS/NZS 2053.7 *Conduits and fittings for electrical installations – Rigid metal conduits and fittings* applicable when the vehicle was built; or
  - Australian Standard AS D26:1972 *Tube fittings with Dryseal American standard taper pipe and unified threads for automotive and industrial use* (i.e. flared fittings); or
  - by an alternative means having at least equivalent effectiveness.

## Battery isolation switch

- A battery isolation switch must be located on the driver's side and to the immediate rear outside the cabin. It must be clearly labelled and easily accessible from outside the cab.

## Vehicle rollover device

- Road tank vehicles must be fitted with a vehicle rollover device that automatically shuts down the engine and isolates the battery. The device should not activate at less than 45° to the vertical.

## Fill and discharge lights

- The lens of any light used to illuminate fill and discharge points must be waterproof and suitably protected by a stout wire guard or be sufficiently strong (thick) to give equivalent protection.

## Hazardous locations

- Any electrical equipment that may be required to be active during cargo transfer and is located within a hazardous zone (see the latest edition of Australian Standard series AS 2430 *Classification of hazardous areas*) must be suitable for use in such a zone. The following hazardous zones are deemed to exist during the whole period of cargo transfer and for 5 minutes thereafter:

**Class 1, Zone 1** – within 500 mm of any point of product release

**Zone 2** – from the rear of the cabin and 8 m radially from any uncapped valve or transfer connection from ground level to a height of 500 mm.

## Sparking equipment

- Any sparking equipment such as relays or switches with make-and-break contacts mounted 500 mm or greater from the rear of the cabin or in a hazardous location must be suitable for use in Zone 1.

## Further information

Contact Resources Safety – Dangerous Goods Safety Branch:

Phone 08 9358 8002

Email [dgsb@docep.wa.gov.au](mailto:dgsb@docep.wa.gov.au)

Web [www.docep.wa.gov.au/ResourcesSafety](http://www.docep.wa.gov.au/ResourcesSafety)