

ASSESSMENT STAGES FOR PARALLEL PROCESSING OF WELL AND SURVEY APPROVALS

This process is Quality Management System Certified to ISO 9001:2008 standard

Dated: 24 May 2010

Definitions

DEC – Department of Environment and Conservation
 PS – Petroleum Safety/Resources Safety Division
 DRET – Department of Resources Energy & Tourism
 Fisheries - Department of Fisheries
 NOPSA - National Offshore Petroleum Safety Authority
 OPGGSA06 – Offshore Petroleum and Greenhouse Gas Storage Act 2006
 PGERA67 – Petroleum and Geothermal Energy Resources Act 1967
 PSLA82 – Petroleum (Submerged Lands) Act 1982
 WAFIC – Western Australian Fishing Industry Council
 NT – Native Title

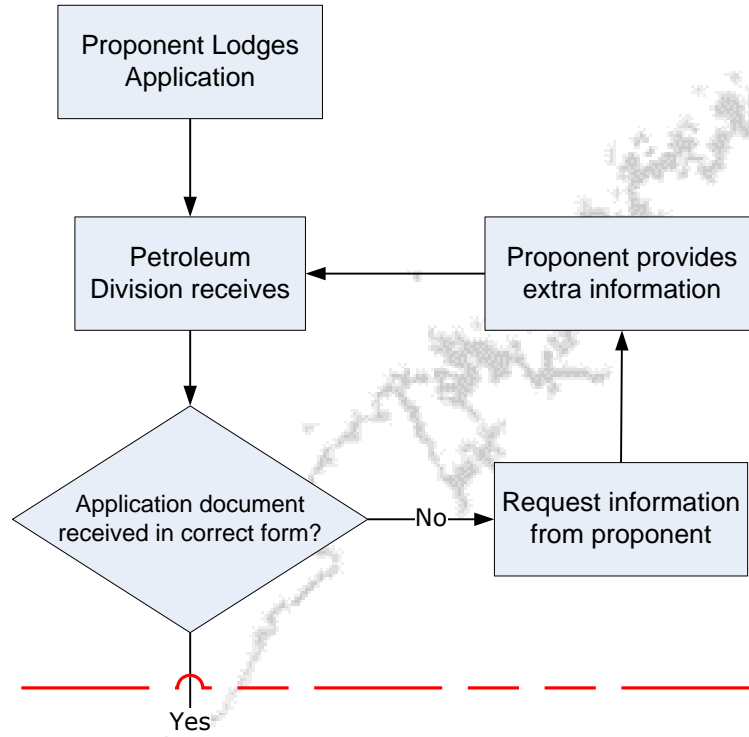

Screening (10 days)

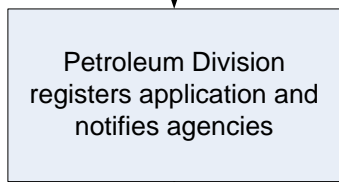

Assessment (20 days)

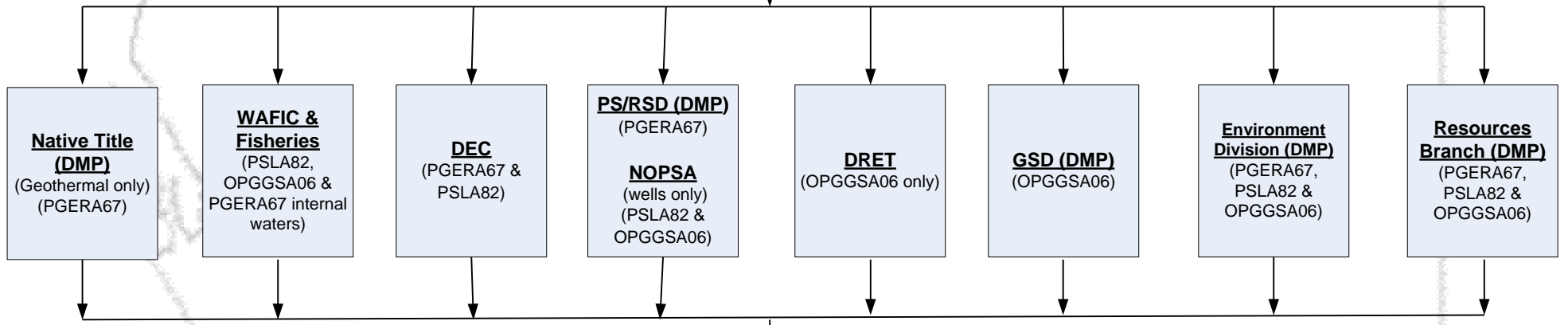

Agencies may directly contact proponent to clarify issues

Section 15A (PGERA) referrals if required (DEC, Heritage, DIA, etc)

Determination (Approval) (10 days)

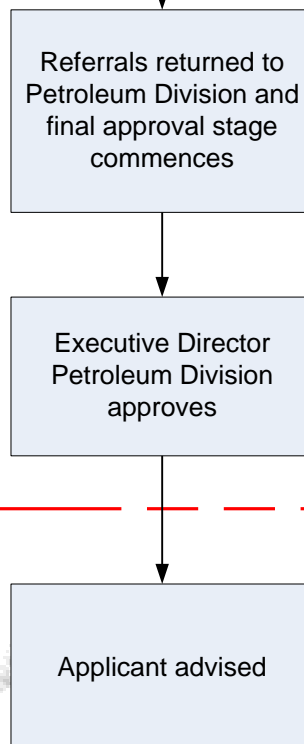

Approval process complete when Executive Director Petroleum Division approves the application