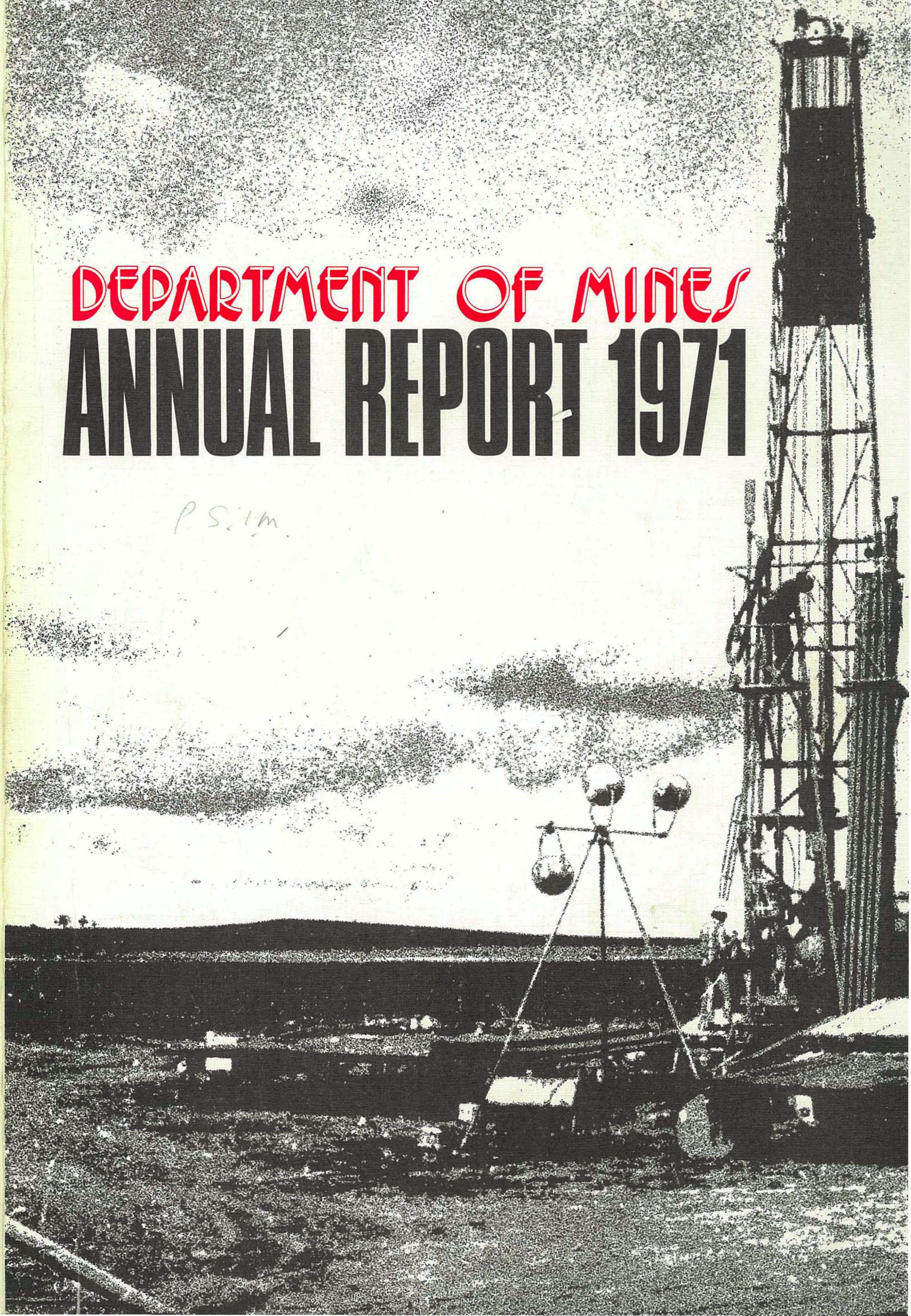


# DEPARTMENT OF MINES ANNUAL REPORT 1971

P. S. M.





R E P O R T O F T H E  
**DEPARTMENT *of* MINES**  
W E S T E R N A U S T R A L I A  
F O R T H E Y E A R 1 9 7 1

By Authority: WILLIAM C. BROWN, Government Printer  
1972

10551/9/72

*To Hon. Minister for Mines.*

*Sir,*

*I have the honour to submit the Annual Report of the Department of Mines of the State of Western Australia for the year 1971, together with the reports from the officers controlling Sub-Departments, and Comparative Tables furnishing statistics relative to the Mining Industry.*

*G. H. COOPER,  
Under Secretary for Mines.*

*Perth, 1972.*

# TABLE OF CONTENTS

## DIVISION I.

	Page
Part 1.—General Remarks .....	7
Iron Ore .....	7
Petroleum .....	7
Gold .....	8
Coal .....	8
Alumina .....	8
Nickel .....	8
Other Minerals .....	8
Part 2.—Comparative Statistics, 1970 and 1971	
Table 1.—Summary of Mineral Production .....	9
Table 1 (a).—Quantity and Value of Minerals produced other than Gold and Silver .....	10
Table 1 (b).—Quantity and Value of Gold and Silver exported and minted .....	10
Table 2.—Royalties .....	11
Table 3.—Amount of Gold reported from each Goldfield .....	11
Diagram of Gold output, value and tonnage, 1915–1971 .....	Facing 12
Table 4.—Output of Gold from the Commonwealth of Australia .....	12
Table 5.—Coal output, value, men employed, output per man .....	12
Graph of Coal output, value and tonnage, 1943–1971 .....	Facing 12
Graph of Coal output of deep and open-cut tonnages, 1955–1971 .....	Facing 12
Table 6.—Mining Tenements applied for and in force under the Mining Act .....	13
Table 6 (a).—Mining Leases applied for and in force under Special Acts .....	13
Table 6 (b).—Permits, Licences and Leases applied for and in force under the Petroleum Act .....	14
Table 6 (c).—Leases under the Mining Act in force in each Goldfield, Mineral field or District .....	14
Table 6 (d).—Claims and Authorised Holdings under the Mining Act in force in each Goldfield, Mineral field or District .....	15
Table 7.—Average number of men engaged in mining .....	16
Part 3.—State Aid to Mining—	17
State Batteries .....	17
Prospecting Scheme .....	17
Geological Survey .....	17
Part 4.—Government Chemical Laboratories .....	17
Part 5.—Explosives Branch .....	17
Part 6.—Mine Workers' Relief Act and Miners' Phthisis Act .....	17
Part 7.—Surveys and Mapping Branch .....	17
Part 8.—Staff .....	18

## DIVISION II.

Report of the State Mining Engineer .....	19
---	----

## DIVISION III.

Report of the Superintendent of State Batteries .....	39
Return of Parcels treated and Tons crushed at State Batteries for year 1971 .....	41
Tailings Treatment, 1971 .....	41
Statement of Revenue and Expenditure for year (Milling) .....	42
Statement of Revenue and Expenditure for year (Tailings Treatment) .....	43

## DIVISION IV.

Report of the Director, Geological Survey .....	45
---	----

## DIVISION V.

Report of the Superintendent, Surveys and Mapping .....	121
---	-----

## DIVISION VI.

Report of the Director, Government Chemical Laboratories .....	127
--	-----

## DIVISION VII.

Report of the Chief Inspector of Explosives .....	163
---	-----

## DIVISION VIII.

Report of the Chairman, Miners' Phthisis Board and Superintendent, Mines Workers' Relief Act .....	167
--	-----

## STATISTICS.

Mining Statistics .....	171
-------------------------	-----

## WESTERN AUSTRALIA

# Report of the Department of Mines for the Year 1971

## DIVISION I

### PART 1— GENERAL REMARKS

*The Honourable Minister for Mines:*

I have the honour to submit for your information a report on the Mining Industry for the year 1971.

The estimated value of the mineral output of the State (including gold, coal and petroleum) for the year was \$646,519,063, an increase of \$67,143,978 compared with that for the preceding year and constitutes an all-time record, 11.6 per cent. higher than the figure set in 1970.

To the end of 1971 the progressive value of the whole mineral production of the State amounted to \$3,336,411,405 of which gold accounted for \$1,105,007,682.

Minerals other than gold and coal rose in value to \$628,863,140, an increase of \$66,384,395 above that for 1970 to establish a new record. This increase was due mainly to the continued expansion of iron ore, nickel and alumina production.

The production increases were reflected in royalty revenue for the year which rose from \$19 million in 1970 to \$24.5 million in 1971.

#### IRON ORE

Iron ore production for export and local use continued to grow, rising from 42,506,000 tons valued at \$328,316,000 in 1970 to 51,204,000 tons valued at \$385,009,000 in 1971. This value would have been even greater but for the devaluation of the American dollar in August of that year.

Five companies were producing iron ore throughout the State during the year, whilst construction of the Robe River project under the Iron Ore (Cleveland-Cliffs) Agreement was, by the end of the year, in an advanced stage.

Hammersley Iron Pty. Limited was the largest producer of iron ore and exported just over 20 million tons of iron ore (including almost 2.3 million tons of pellets) valued at a little over \$159 million from Mt. Tom Price through Dampier.

Mt. Newman Mining Co. Pty. Limited was the second largest producer and exported through Port Hedland almost 18.3 million tons of Mt. Whaleback

iron ore valued at about \$131.7 million. Of this, 763,000 tons were shipped to the Eastern States of Australia.

Goldsworthy Mining Limited ranked third in production with almost 6.6 million tons of iron ore exported from the Mt. Goldsworthy deposit at a value of almost \$50 million.

Dampier Mining Company Limited continued production of iron ore from Cockatoo and Koolan Islands and reported just over 2.4 million tons of ore exported overseas and valued at about \$15.6 million, and almost 1.4 million tons valued at a little over \$9.7 million shipped to steelworks, of The Broken Hill Proprietary Company Limited, within Australia. Also, this company reported 1.8 million tons of iron ore from Koolyanobbing (valued at about \$13.6 million) railed to Kwinana. Of this, 541,300 tons were shipped to the Eastern States and 385,500 tons exported overseas.

Western Mining Corporation reported production of 663,000 tons from Koolanooka valued at about \$5.2 million f.o.b. Geraldton.

#### PETROLEUM (Crude Oil)

Sales of oil from Barrow Island during 1971 decreased slightly from 16.6 million barrels valued at \$53.7 million in 1970 to 16.4 million barrels valued at \$36.5 million in 1971. The marked decrease in value resulted mainly from the world-wide drop, late in 1970, in prices for crude oil.

Offshore drilling activity continued during 1971 and promising discoveries of gas were made at Scott Reef, North Rankin, Rankin and Goodwyn wells.

#### (Natural Gas)

The natural gas pipeline from Dongara to Pinjarra was completed late in 1971, and by the end of the year some gas was being reticulated to industry and domestic consumers in the metropolitan area. Consumption was steadily increasing at the end of the year.

## GOLD

The estimated value of gold received at the Perth Mint plus that exported in gold-bearing material was \$11,921,570, an increase of \$852,521 compared with the figure for 1970. This increase was due mainly to significantly higher premiums obtained on the premium market and to some extent an increase in production of 6,401 fine ounces.

The quantity of gold advised as being received at the Perth Mint (347,071·08 fine ounces) together with that contained in gold-bearing material exported for treatment (938·24 fine ounces) totalled 348,009·32 fine ounces, an increase of 6,401·25 fine ounces over the previous year's production.

Details of gold production for the year reported directly to the Department, as distinct from that received at the Mint are set out in Table I. The total tonnage of gold ore treated was 1,675,109 tons being 64,911 tons more than for 1970.

West Australian gold included in sales on overseas premium markets by the Gold Producers' Association Ltd., for the period September, 1970, to August, 1971, totalled 367,809 fine ounces. The premium received in excess of the Mint value amounted to \$1,317,849 an overall average of \$3·7868 per fine ounce as compared with an average of \$1·0691 per fine ounce for the period September, 1969, to August, 1970.

Subsidy payments by the Commonwealth Government during the year under the Gold-Mining Industry Assistance Act totalled \$1,823,776, a decrease of \$1,195,463 compared with the previous year. This decrease in subsidy payments is the result of the higher prices obtained for gold sold on the free market. Where a producer receives an amount in excess of the official price of \$31·25 per fine ounce as a result of sales on overseas premium markets or otherwise, the subsidy payable is reduced by seventy-five per cent. of the amount of the excess. Of the subsidy paid \$1,795,969 went to large producers and \$27,806 went to small producers

## COAL

Coal production from Collie during the year showed a decrease of 26,110 tons against that for 1970 and the overall average value per ton rose by 3 cents.

Figures for the last three years were—

	1969	1970	1971
Tons	1,090,530	1,197,734	1,171,624
Total Value	\$4,804,089	\$5,827,291	\$5,734,353
Average value per ton	\$4·4052	\$4·8653	\$4·8943
Average Effective Workers	628	835	623
Proportion of Deep Mined Coal	43·31%	39·02%	34·86%

## ALUMINA (from Bauxite)

Alcoa of Australia (W.A.) N.L. increased its output of alumina for 1971 from its Kwinana refinery to 1,255,000 tons having an estimated value of \$80 million. The tonnage increase over that for 1970 was 300,000.

## NICKEL

The total value of nickel in concentrates and nickel briquettes and powder amounted to an estimated \$95 million in 1971 as compared with \$87·4 million in 1970. The various sources of the nickel ores and concentrates which are at present all handled at some stage by Western Mining Corporation are commented on in some detail in the State Mining Engineer's report.

## OTHER MINERALS

Other minerals to yield over a million dollars for the year were Ilmenite—\$7·9 million, Salt—\$7·6 million, Manganese—\$2·1 million, Tin concentrates \$1·8 million, Leucocxene—\$1 million, whilst Pig Iron valued at \$3·7 million was recovered by the Charcoal Iron and Steel Industry at Wundowie.

Despite the down-turn in world trade generally due to the international monetary crisis of 1971, the mining industry in Western Australia appears to be very soundly based. Genuine mineral exploration, expansion of present projects and development of new projects are being steadily pursued. It is felt that the industry is fully prepared to cope with any improvement in trade and can look forward to the future with justifiable optimism.

PART 2—COMPARATIVE STATISTICS

TABLE 1  
SUMMARY

Mineral Production : Quantity, Value, Persons Engaged

	1970	1971	Variation
<b>IRON ORE—</b>			
<i>Reported to Department—</i>			
Tons ....	42,604,644	51,297,774	+ 8,693,130
Value (\$A) ....	\$331,821,787	\$388,706,948	+ \$56,885,161
Persons Engaged ....	2,183	2,754	+ 571
<b>PETROLEUM—CRUDE OIL—</b>			
<i>Reported to Department—</i>			
Barrels ....	16,663,905	16,352,920	— 310,985
† Value (\$A) ....	\$53,710,900	\$36,466,886	— \$17,244,014
<i>Persons Engaged—</i>			
Effective Workers (excluding absentees) ....	166	108	— 60
<b>GOLD—</b>			
<i>Reported to Department (Mine Production)—</i>			
Ore Tons ....	1,740,020	1,675,109	— 64,911
Gold (fine ounces) ....	349,999	344,757	— 5,242
Average Grade (dwts. per ton) ....	4.023	4.116	+ .093
<i>Persons Engaged—</i>			
(a) Effective Workers (excluding absentees) ....	1,942	1,775	— 167
(b) Total Pay Roll ....	2,157	1,962	— 195
<i>Mint and Export (Realised Production)—</i>			
Gold (fine ounces) ....	341,608	348,009	+ 6,401
Estimated Value (\$A) (including Overseas Gold Sales Premium)	\$11,069,049	\$11,921,570	+ \$852,521
<b>COAL—</b>			
<i>Reported to Department (Mine Production)—</i>			
Tons ....	1,197,734	1,171,624	— 26,110
Value (\$A) ....	\$5,827,291	\$5,734,353	— \$92,938
<i>Persons Engaged—</i>			
Effective Workers (excluding absentees) ....	635	623	— 12
<b>OTHER MINERALS—</b>			
<i>Reported to Department—</i>			
Value (\$A) ....	\$176,946,058	\$203,689,306	+ \$26,743,248
<i>Persons Engaged—</i>			
Effective Workers (excluding absentees) ....	3,586	4,244	+ 658
<b>TOTAL ALL MINERALS—</b>			
Value (\$A) ....	\$579,375,085	\$646,519,063	+ \$67,143,978
<i>Persons Engaged—</i>			
Effective Workers ....	8,512	9,502	+ 990

† Based on the price assessed from time to time by the Tariff Board for Barrow Island crude oil at Kwinana.

TABLE 1 (a)  
Quantity and Value of Minerals, other than Gold and Silver, produced during Years 1969 and 1970  
Western Australia

Mineral	1970		1971		Increase or Decrease for Year Compared with 1970	
	Quantity	Value	Quantity	Value	Quantity	Value
Alumina (from Bauxite) ....	Tons 949,987.00	\$A 60,799,000	Tons 1,255,209.00	\$A 80,333,200	+ Tons 305,222.00	+ \$A 19,534,200
Asbestos (Chrysotile) ....	.....	.....	50.60	2,125	+ 50.60	+ 2,125
Barytes ....	565.05	6,916	.....	.....	+ 565.05	+ 6,916
Beryl ....	15.55	5,796	63.42	17,703	+ 47.87	+ 11,907
Bismuth ....	lbs. 3,780.00	6,867	.....	.....	- lbs. 3,780.00	- 6,867
Building Stone (Quartzite) ....	Tons 1,516.00	7,240	1,269.00	5,490	- Tons 247.00	- 1,750
(Quartz) ....	4,960.00	60,682	9,838.00	117,077	+ 4,878.00	+ 56,395
(Granite—Facing Stone) ....	.....	.....	638.00	18,016	+ 638.00	+ 18,016
(Sandstone) ....	.....	.....	30.00	180	+ 30.00	+ 180
(Spongolite) ....	140.50	1,859	145.00	1,965	+ 4.50	+ 106
Clays (Bentonite) ....	115.50	774	20.00	120	+ 95.50	+ 654
(Cement Clay) ....	22,413.07	47,551	7,731.23	11,022	- 14,681.84	- 36,529
(Fireclay) ....	130,810.00	120,051	91,040.00	66,123	- 39,770.00	- 53,928
(Kaolin) ....	187.48	1,113	.....	.....	- 187.48	- 1,113
(White Clay—Ball Clay) ....	850.00	9,631	656.00	7,432	- 194.00	- 2,199
(Brick, Pipe and Tile Clay) ....	30,558.00	50,947	65,421.25	33,547	+ 34,863.25	+ 17,400
Coal ....	1,197,733.50	5,827,291	1,171,623.64	5,734,353	- 26,109.86	- 92,938
Cobalt (Metallic By-Product Nickel Mining) ....	332.73	1,197,680	202.43	801,560	- 130.30	- 396,120
Copper (Metallic By-Product Nickel Mining) ....	2,095.66	2,037,360	989.04	998,400	- 1,156.62	- 1,038,960
Copper Ore and Concentrates ....	2,978.20	662,762	1,990.92	283,322	- 987.28	- 379,440
Cupreous Ore and Concentrates ....	603.99	126,890	428.13	52,643	- 175.86	- 74,247
Felspar ....	645.00	9,675	414.50	6,217	- 230.50	- 3,458
Glass Sand ....	95,569.00	*34,046	172,963.14	*82,927	+ 77,394.14	+ 48,881
Gypsum ....	89,987.11	247,915	166,769.78	515,256	+ 76,782.67	+ 267,341
Iron Ore (Pig Iron Recovered) ....	61,537.00	3,505,910	59,245.00	3,697,908	+ 2,292.00	+ 191,998
(Exported) ....	40,626,314.65	308,950,211	48,920,181.71	361,587,134	+ 8,293,867.06	+ 52,636,923
(Pellets) ....	1,879,689.81	19,365,666	2,283,318.42	23,421,906	+ 404,128.61	+ 4,056,240
Lead Ores and Concentrates ....	456.59	64,779	40.16	3,899	- 416.43	- 60,880
Limestone* ....	1,168,849.67	1,246,403	1,284,680.05	1,373,218	+ 115,830.38	+ 126,815
Lithium Ores (Petalite) ....	771.00	12,259	1,647.50	26,190	+ 876.50	+ 13,931
Magnesite ....	2,180.00	31,600	60.00	900	- 2,120.00	- 30,700
Manganese (Metallurgical Grade) ....	202,373.50	3,743,921	123,308.00	2,138,974	- 74,065.50	- 1,604,947
Mineral Beach Sands (Ilmenite) ....	550,660.15	5,984,389	690,495.07	7,940,866	+ 139,834.92	+ 1,956,477
(Monazite) ....	4,693.23	621,603	3,090.28	447,876	- 1,602.95	- 173,727
(Rutile) ....	2,251.61	200,483	218.75	29,008	- 2,032.86	- 171,475
(Leucoxene) ....	12,130.30	634,171	10,936.30	1,012,004	- 1,194.00	+ 377,833
(Zircon) ....	60,956.02	1,508,811	30,775.31	926,866	- 30,180.71	- 581,945
(Xenotime) ....	55.00	71,922	56.00	73,921	+ 1.00	+ 1,999
Nickel Concentrates ....	265,439.84	85,524,150	297,952.21	91,900,900	+ 32,512.37	+ 6,376,750
Nickel Ore ....	40,116.05	1,892,880	82,219.17	2,998,040	+ 52,103.12	+ 1,105,160
Ochre (Red) ....	608.54	6,085	.....	.....	+ 608.54	+ 6,085
Peat ....	974.25	20,888	1,490.00	29,031	+ 515.75	+ 8,143
Platinum (Metallic By-Product Nickel Mining) ....	Troy ozs. 1,449.18	155,454	.....	.....	- Troy ozs. 1,449.18	- 155,454
Petroleum—Crude Oil ....	bbls 16,663,905.00	53,710,900	bbls 16,352,920.00	36,466,886	- bbls 310,985.00	- 17,244,014
(Natural Gas) ....	.....	.....	m.c.f. 1,221,221.00	158,759	+ m.c.f. 1,221,221.00	+ 158,759
Pyrites Ore and Concentrates (For Sulphur) ....	Tons 1,398.79	15,765	.....	.....	- Tons 1,398.79	- 15,765
Salt ....	1,815,935.62	6,476,489	2,370,378.00	7,622,123	+ 554,442.38	+ 1,145,634
Semi Precious Stones ....	lbs. 72,269.00	45,224	lbs. 275,300.50	91,560	+ lbs. 203,031.50	+ 46,336
Talc ....	Tons 31,293.93	742,257	Tons 23,617.00	747,281	- Tons 2,676.93	+ 5,024
Tanto/Columbite Ores and Concentrates ....	68.58	246,510	73.85	383,650	+ 5.27	+ 137,140
Tin Concentrates ....	759.06	1,606,537	848.29	1,794,081	+ 89.23	+ 187,544
Vermiculite ....	299.42	1,797	54.10	325	- 245.32	- 1,472
Total ....	.....	567,649,110	.....	633,961,984	.....	+ 66,312,874

TABLE 1 (b)  
Quantity and Value of Gold and Silver Exported and Minted during Years 1970 and 1971

Minerals	1970		1971		Increase or Decrease for Year Compared with 1970	
	Quantity	Value	Quantity	Value	Quantity	Value
Gold (Exported and Minted)....	Fine oz. 341,608.07	\$A †11,069,049	Fine Oz. 343,009.32	\$A †11,921,570	+ Fine Oz. 6,401.25	+ \$A 852,521
Silver (Exported and Minted) ....	418,769.71	656,926	445,850.72	635,509	+ 27,081.01	- 21,417
Total ....	.....	11,725,975	.....	12,557,079	.....	+ 831,104
Grand Total ....	.....	579,375,085	.....	646,519,063	.....	+ 67,143,978

\* Incomplete. † Including Overseas Gold Sales Premium.



TABLE 2  
ROYALTIES

Mineral	Royalty Collected		Increase or Decrease Compared with 1970
	1970	1971	
Alumina	218,722.45	339,045.90	+ 120,323.45
Amethyst	.50	1.77	+ 1.27
Asbestos	....	7.59	+ 7.59
Barytes	31.18	....	- 31.18
Bentonite	5.80	1.00	- 4.80
Beryl	....	115.00	+ 115.00
Bismuth	36.70	....	- 36.70
Building Stone	464.41	1,087.69	+ 623.28
Chalcedony	....	28.26	+ 28.26
Chrysoprase	185.00	329.88	+ 144.88
Clay	7,324.84	5,376.34	- 1,948.50
Coal	29,267.23	30,562.04	+ 1,294.81
Cobalt	469.30	460.34	- 8.96
Dravite	8.42	17.50	+ 9.08
Felspar	33.35	19.25	- 14.10
Glass Sand	4,498.20	8,774.59	+ 4,276.39
Gypsum	3,134.48	7,027.92	+ 3,893.44
Ilmenite	37,588.49	45,760.36	+ 8,171.87
Iron Ore	15,901,333.34	21,497,907.05	+ 5,596,573.71
Leucosene	1,000.67	297.02	- 703.65
Limestone	18,677.00	22,910.63	+ 4,233.63
Magnesite	327.00	3.00	- 324.00
Manganese	27,695.93	22,992.22	- 4,703.71
Monazite	1,094.53	2,231.86	+ 1,137.33
Moss Opal	3.46	63.75	+ 60.29
Natural Gas	....	2,670.53	+ 2,670.53
Nickel	593,656.22	628,128.65	+ 34,472.43
Ochre	30.43	....	- 30.43
Oil (Crude)	2,054,396.99	1,784,216.59	- 270,180.40
Petalite	108.50	123.40	+ 14.90
Platinum	298.29	....	- 298.29
Pyrites	735.60	....	- 735.60
Rutile	138.25	32.74	- 105.51
Salt	76,891.32	117,019.12	+ 40,127.80
Talc	3,948.51	2,499.29	- 1,449.22
Tanto Columbite	601.16	2,564.73	+ 1,963.57
Tin	132.90	165.27	+ 32.37
Vermiculite	14.97	2.70	- 12.27
Xenotime	118.06	167.05	+ 48.99
Zircon	3,498.79	2,425.31	- 1,073.48
	18,986,472.27	24,525,036.34	+ 5,538,564.07

TABLE 3

Showing for every Goldfield the amount of Gold reported to the Mines Department as required by the Regulations, also the percentage for the several Goldfields of the total reported (and the average value of the yield in pennyweights per ton of ore treated).

Goldfield	Reported Yield		Percentage for each Goldfield		† Average Yield per ton of ore treated	
	1970	1971	1970	1971	1970*	1971*
1. Kimberley	Fine Ozs.	Fine Ozs.	Per cent.	Per cent.	Dwts.	Dwts.
2. West Kimberley	....	....	....	....	....	....
3. Pilbara	531	306	.152	.089	17.241	9.281
4. West Pilbara	....	45	....	.013	....	....
5. Ashburton	....	....	....	....	....	....
6. Gascayne	826	....	.236	....	28.844	....
7. Peak Hill	9	20	.002	.006	....	....
8. East Murchison	206	38	.059	.010	10.953	3.855
9. Murchison	6,639	14,610	1.895	4.233	4.520	4.568
10. Yalgoo	....	17	....	.005	....	4.519
11. Mt. Margaret	787	739	.225	.214	7.282	14.812
12. North Coolgardie	129	110	.037	.032	2.628	2.537
13. Broad Arrow	381	277	.109	.080	9.491	1.996
14. North-East Coolgardie	808	307	.231	.089	2.285	1.635
15. East Coolgardie	284,284	276,410	81.133	80.096	3.700	3.792
16. Coolgardie	628	451	.179	.131	2.130	14.679
17. Yilgarn	3,004	1,880	.857	.545	9.275	9.698
18. Dundas	50,928	49,160	14.535	14.245	6.768	6.977
19. Phillips River†	1,119	730	.319	.212	5.348	....
20. South-West Mineral Field	19	....	.005	....	10.428	....
21. State Generally	92	....	.026	....	....	....
	350,390	345,098	100.000	100.000	4.023	4.116

\* Gold at \$A31.25 per fine oz. or \$A1.5625 per pennyweight.  
† Includes By-product of Copper Mining.  
‡ Averages exclude alluvial and dollied gold.

TABLE 4

*The Output of Gold from the Commonwealth of Australia during 1971*

State	Output of Gold	Value*†	Percentage of Total
Western Australia	348,009	10,875,281	53.92
Northern Territory	169,658	5,301,813	26.29
Queensland	61,468	1,920,875	9.52
Tasmania	53,365	1,667,656	8.27
New South Wales	9,444	295,125	1.46
Victoria	3,471	108,469	.54
South Australia	20	625	...
Total	645,435	20,169,844	100.00

\* \$A31.25 per fine ounce.

† Exclusive of Overseas Gold Sales Premium by Gold Producers' Association

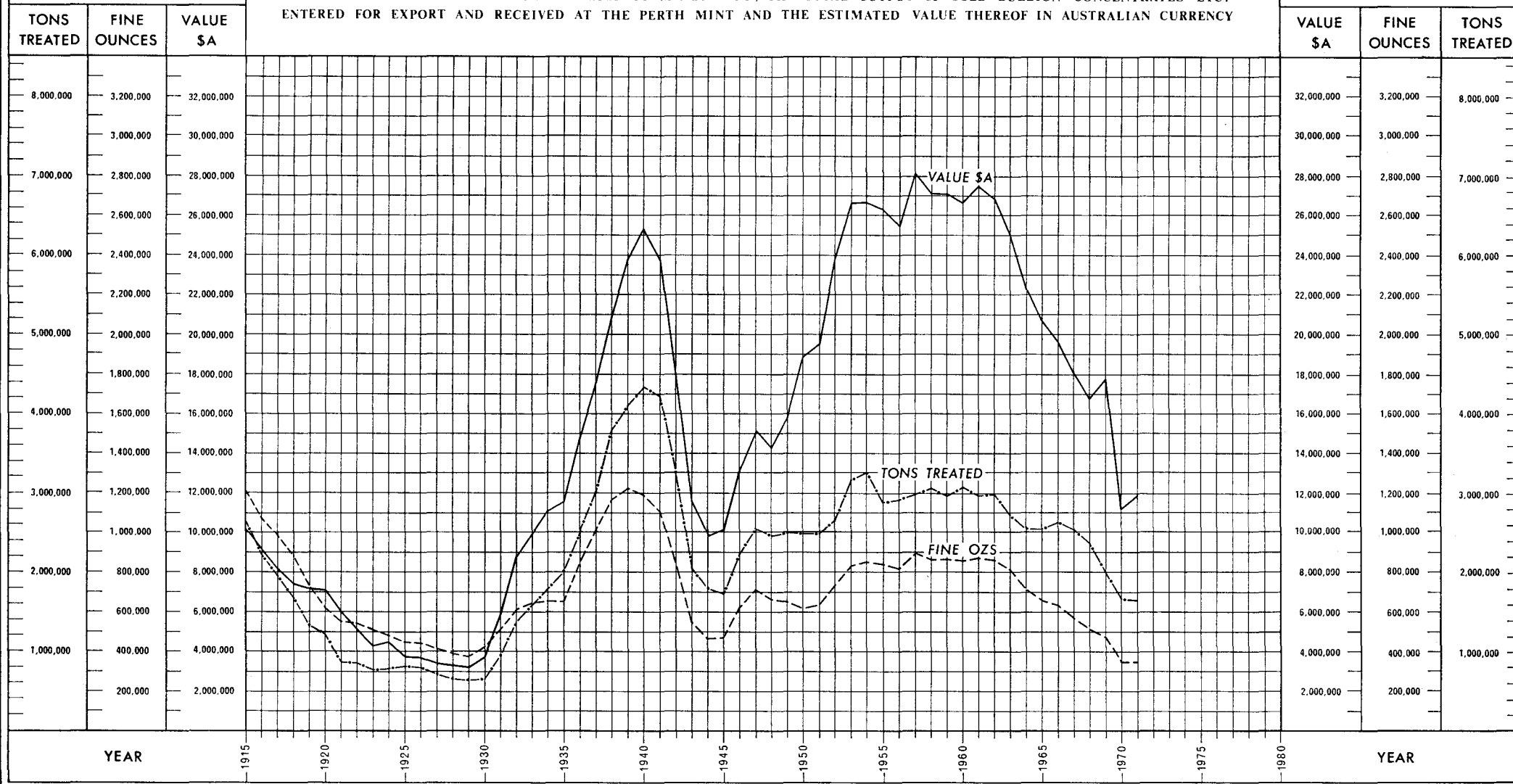
TABLE 5

*Total Coal output from Collie River Mineral Field, 1970 and 1971, estimated Value therefrom, Average Number of Men Employed and Output per Man.*

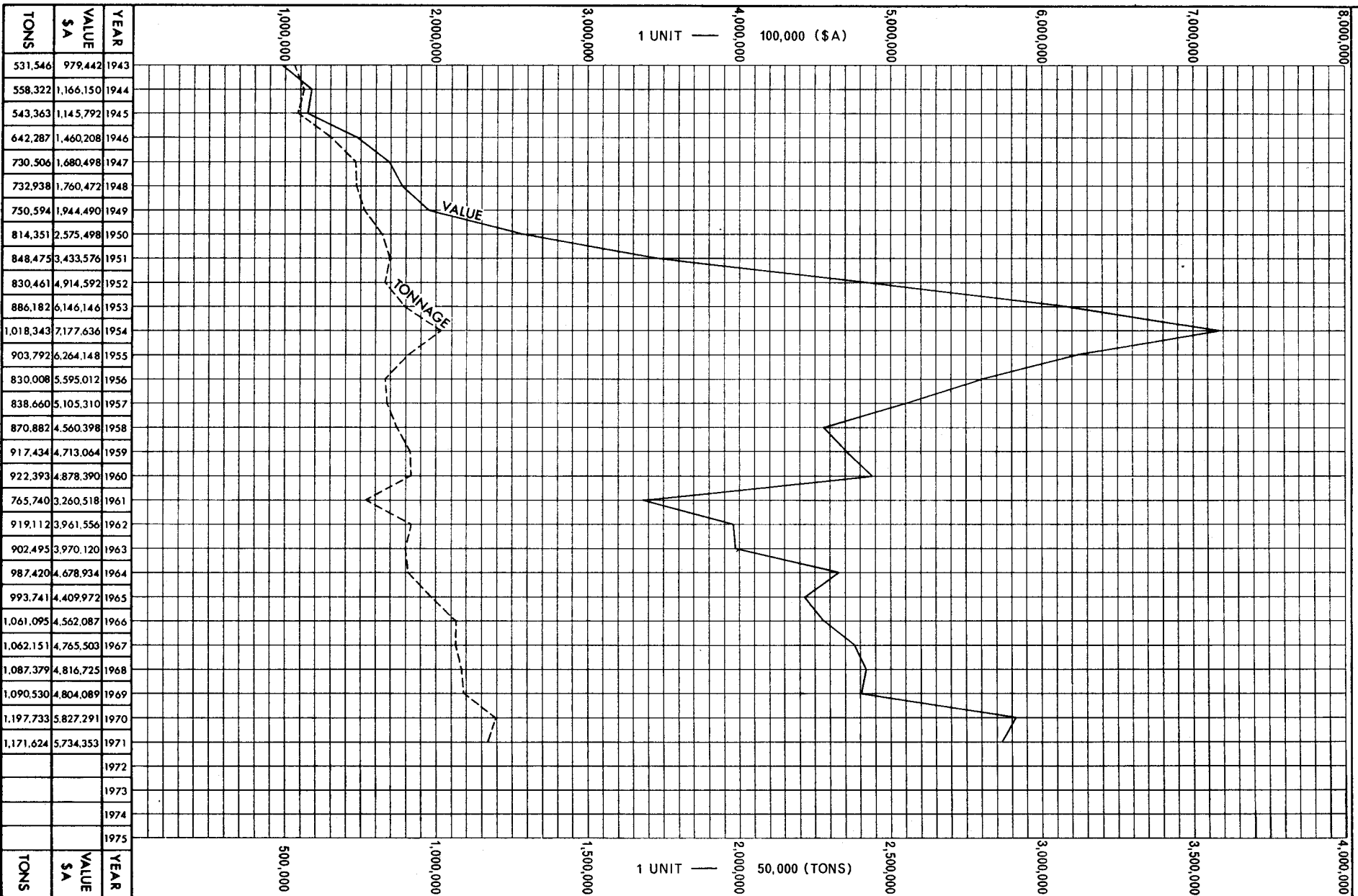
Year	Total Output	Estimated Value	Men Employed			Output per Man Employed		
			Above Ground	Under Ground	Open Cuts	In Open Cuts	Under Ground	Above and Under Ground
Deep Mining—	Tons	\$A	No.	No.	No.	Tons	Tons	Tons
1970	467,298	2,829,376	96	335	...	...	1,394	1,082
1971	408,380	2,874,291	97	317	...	...	1,288	986
Open Cut Mining—								
1970	730,436	2,997,915	...	...	204	3,581	...	...
1971	763,244	2,860,062	...	...	209	3,652	...	...
Totals—								In all Mines
1970	1,197,734	5,827,291	96	335	204	...	...	1,886
1971	1,171,624	5,734,353	97	317	209	...	...	1,881

# DIAGRAM OF GOLD OUTPUT

SHOWING TONNAGES TREATED AS REPORTED TO MINES DEPT., THE TOTAL OUTPUT OF GOLD BULLION CONCENTRATES ETC. ENTERED FOR EXPORT AND RECEIVED AT THE PERTH MINT AND THE ESTIMATED VALUE THEREOF IN AUSTRALIAN CURRENCY



**GRAPH OF COAL OUTPUT**  
SHOWING QUANTITIES AND VALUES AS REPORTED TO MINES DEPARTMENT



**GRAPH OF TREND IN COAL OUTPUT**  
 SHOWING COMPARISON OF ANNUAL TONNAGE AND PERCENTAGES  
 BETWEEN DEEP AND OPEN CUT MINING

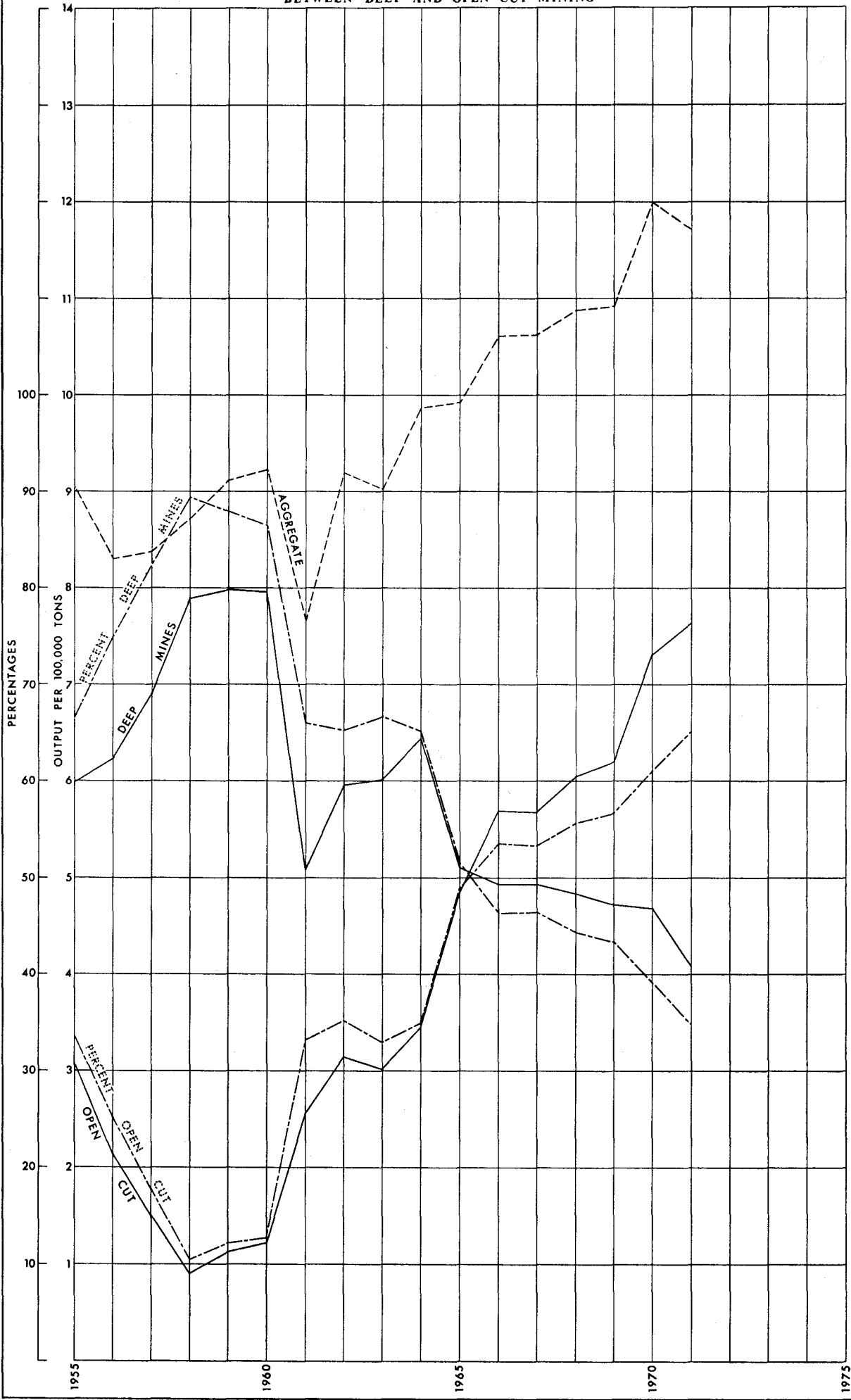


TABLE 6

MINING ACT, 1904.

## LEASES AND OTHER HOLDINGS UNDER VARIOUS ACTS RELATING TO MINING.

Total Number and Acreage of Mining Tenements applied for during 1971 and in force as at 31st December, 1971 (compared with 1970)

	Applied for				In Force			
	1970		1971		1970		1971	
	No.	Acres	No.	Acres	No.	Acres	No.	Acres
<b>Gold—</b>								
Gold Mining Leases	226	4,761	130	5,411	1,375	26,308	1,370	26,022
Dredging Claims	15	4,500	.....	.....	5	1,182	2	600
Prospecting Areas	276	5,696	236	4,286	221	4,191	149	2,801
Temporary Reserves	.....	.....	.....	.....	173	49,949	42	11,083
<b>Totals</b>	<b>517</b>	<b>14,957</b>	<b>366</b>	<b>9,697</b>	<b>1,774</b>	<b>81,630</b>	<b>1,563</b>	<b>40,506</b>
<b>Coal—</b>								
Coal Mining Leases	60	19,944	1,254	363,767	52	15,016	52	15,016
Prospecting Areas	27	74,190	401	1,060,529	.....	.....	15	43,920
Temporary Reserves	.....	.....	8	550,592	2	4,320	2	4,320
<b>Totals</b>	<b>87</b>	<b>94,134</b>	<b>1,663</b>	<b>1,974,888</b>	<b>54</b>	<b>19,336</b>	<b>69</b>	<b>63,256</b>
<b>Other Minerals—</b>								
Mineral Leases	100	25,278	234	65,282	299	45,933	347	59,731
Dredging Claims	712	207,903	305	85,858	413	32,982	411	38,098
Mineral Claims	42,866	12,150,760	14,394	3,902,212	20,272	5,344,357	27,795	7,593,074
Prospecting Areas	198	38,722	44	958	86	2,023	34	751
Temporary Reserves	116	6,483,840	31	5,773,210	655	40,615,982	534	30,115,538
<b>Totals</b>	<b>43,992</b>	<b>18,906,503</b>	<b>15,008</b>	<b>9,827,520</b>	<b>21,725</b>	<b>46,041,277</b>	<b>29,121</b>	<b>37,807,187</b>
<b>Other Holdings—</b>								
Miner's Homestead Leases	2	302	.....	.....	335	33,786	334	33,373
Miscellaneous Leases	.....	.....	20	17,430	102	1,660	104	1,817
Residence Areas	1	1	2	2	62	50	62	51
Business Areas	2	2	5	5	26	15	28	24
Machinery Areas	4	16	.....	.....	26	78	21	57
Tailings Areas	2	10	.....	.....	24	97	24	89
Garden Areas	9	43	2	6	70	243	70	245
Quarrying Areas	45	1,016	58	1,170	45	854	87	1,701
Water Rights	11	346	7	1,489	141	3,210	125	2,781
Licenses to Treat Tailings	79	.....	38	.....	22	.....	54	.....
<b>Totals</b>	<b>155</b>	<b>1,736</b>	<b>132</b>	<b>20,102</b>	<b>853</b>	<b>39,993</b>	<b>909</b>	<b>40,138</b>
<b>Grand Totals</b>	<b>44,751</b>	<b>19,017,330</b>	<b>17,169</b>	<b>11,832,207</b>	<b>24,406</b>	<b>46,182,236</b>	<b>31,662</b>	<b>37,951,087</b>

TABLE 6 (a)

## SPECIAL ACTS

Leases applied for during 1971 and in force at 31st December, 1971 (Compared with 1970)

Mineral	Applied for				In Force			
	1970		1971		1970		1971	
	No.	Acres	No.	Acres	No.	Acres	No.	Acres
Bauxite	.....	.....	.....	.....	7	3,137,280	7	3,137,280
Iron	1	32,000	1	161,426	5	451,106	5	451,106
Salt	.....	.....	.....	.....	2	593,430	2	593,430
<b>Totals</b>	<b>1</b>	<b>32,000</b>	<b>1</b>	<b>161,426</b>	<b>14</b>	<b>4,181,816</b>	<b>14</b>	<b>4,181,816</b>

TABLE 6 (b)  
PETROLEUM ACTS

Permits, Licences and Leases applied for during 1971 and in force as at 31st December, 1971 (Compared with 1970)

Holding	Applied for				In Force			
	1970		1971		1970		1971	
	No.	Blocks	No.	Blocks	No.	Blocks	No.	Blocks
Onshore—								
Petroleum Act, 1967—								
Exploration Permits	44	4,273	5	393	38	5,517	53	6,510
Production Licences	....	....	3	14	....	....	3	14
Petroleum Lease (Barrow Island)	....	....	....	....	1	8	1	8
Totals	44	4,273	8	407	39	5,525	57	6,532
Petroleum Pipelines Act, 1969—								
Pipeline Licences	1	(252.8 miles)	2	(44.26 miles)	1	(252.8 miles)	3	(272.38 miles)
Totals	1	(252.8 miles)	2	(44.26 miles)	1	(252.8 miles)	3	(272.38 miles)
Offshore—								
Petroleum (Submerged Lands) Act, 1969:								
Exploration Permits	....	....	11	2,868	35	8,808	34	8,727
Production Licences	....	....	....	....	....	....	....	....
Petroleum Lease (Barrow Marine)	....	....	....	....	1	12	1	12
Totals	....	....	11	2,868	36	8,820	35	8,739
Grand Totals	44	4,273	19	3,275	75	14,345	92	15,271

(A part block contains approximately 30 sq. miles and the numbers given above include part blocks.)

TABLE 6 (c)  
MINING ACT, 1904

Leases in Force at 31st December, 1971 in each Goldfield, Mineral Field or District

Goldfield, Mineral Field, or District	Gold Mining Leases		Mineral Leases		Miner's Homestead Leases		Miscellaneous Leases	
	No.	Acres	No.	Acres	No.	Acres	No.	Acres
Ashburton	....	....	6	112	....	....	....	....
Black Range	50	1,205	....	....	....	....	....	....
Broad Arrow	28	450	2	562	....	....	....	....
Bulong	5	78	....	....	....	....	1	3
Collie	....	....	....	....	....	....	49	14,491
(Private Property)	....	....	....	....	....	....	2	520
Coolgardie	85	1,678	147	38,761	22	1,859	6	60
Cue	12	255	3	510	4	1,113	....	....
Day Dawn	18	350	7	1,151	1	20	....	....
Dundas	418	9,283	....	....	19	935	....	....
East Coolgardie	314	5,570	....	....	63	3,280	61	1,144
Gascoyne	9	190	....	....	....	....	....	....
Greenbushes	....	....	65	9,266	10	551	....	....
Kanowna	10	169	....	....	12	702	....	....
Kimberley	1	24	....	....	....	....	....	....
Kunanalling	3	59	....	....	2	520	....	....
Kurnalpi	3	72	....	....	....	....	....	....
Lawlers	15	278	....	....	5	1,110	....	....
Marble Bar	83	1,299	3	144	....	....	13	260
Meekatharra	35	178	....	....	11	1,866	1	1
Menzies	17	330	....	....	7	740	1	10
Mount Magnet	82	1,335	4	38	1	10	....	....
Mount Malcolm	22	382	....	....	9	1,270	....	....
Mount Margaret	3	54	....	....	7	58	....	....
Mount Morgans	2	33	....	....	....	....	....	....
Niagara	2	29	....	....	1	20	....	....
Northampton	....	....	8	149	....	....	....	....
(Private Property)	....	....	2	33	....	....	....	....
Nullagine	27	489	....	....	2	22	3	49
Peak Hill	....	....	15	547	5	250	1	15
Phillips River	3	30	12	266	105	14,614	....	....
(Private Property)	....	....	1	291	....	....	....	....
South-West	2	48	2	63	....	....	1	5
(Private Property)	....	....	13	3,102	....	....	....	....
Ularring	14	236	....	....	1	20	....	....
West Kimberley	....	....	23	755	....	....	....	....
West Pilbara	....	....	13	218	3	35	10	223
Wiluna	5	116	11	1,834	17	3,879	....	....
Yalgoo	9	139	2	33	1	10	....	....
Yerilla	18	352	6	1,800	1	10	....	....
Yilgarn	63	1,077	2	96	25	479	7	52
(Private Property)	12	234	....	....	....	....	....	....
Outside Proclaimed	....	....	....	....	....	....	....	....
Totals	1,370	26,022	347	59,731	334	33,373	156	16,833
Gold Mining Leases on Crown Land	....	....	....	....	1,358	25,788 acres	....	....
Gold Mining Leases on Private Property	....	....	....	....	12	234 "	....	....
Mineral Leases on Crown Land	....	....	....	....	331	56,305 "	....	....
Mineral Leases on Private Property	....	....	....	....	16	3,426 "	....	....
Miner's Homestead Leases on Crown Land	....	....	....	....	334	33,373 "	....	....
Other Leases on Crown Land	....	....	....	....	154	16,313 "	....	....

TABLE 6 (d)  
MINING ACT, 1904

Claims and Authorised Holdings in Force at 31st December, 1971 in each Goldfield, Mineral Field or District

Goldfield, Mineral Field or District	Prospecting Areas		Dredging Claims		Mineral Claims		Residence Areas		Business Areas		Machinery Areas		Tailings Areas		Garden Areas		Water Rights		Quarrying Areas		
	Number	Acres	Number	Acres	Number	Acres	Number	Acres	Number	Acres	Number	Acres	Number	Acres	Number	Acres	Number	Acres	Number	Acres	
Ashburton	1	24			378	99,889													2	48	
Black Range	5	120			699	207,439	4	1													
Broad Arrow	15	286	2	600	534	143,129	1	1	1	1							3	8			
Bulong	3	56			397	111,673															
Collie																					
(Private Property)																					
Coolgardie	33	633			2,396	663,118	3	3			1	1			4	11	6	51	25	568	
Cue	11	168			761	219,001	2	1									1	3			
Day Dawn	1	24			110	31,717									4	20					
Dundas	3	60			1,483	405,558							1	5	1	3	2	12			
East Coolgardie	8	107			502	134,155	33	33			1	2	10	46	9	42	11	32	4	42	
Gascoyne	1	24	2	410	441	113,586													15	346	
Greenbushes					1	20	1	1							9	35	2	31			
Kanowna	2	45			693	193,835									2	7	1	1			
Kimberley	3	52			1,229	346,230									1	2			3	48	
Kunanalling	2	36	2	600	585	162,451											2	24			
Kurnalpi					770	222,970															
Lawlers	1	24			770	221,313					2	6					1	1			
Marble Bar	4	92	380	32,458	2,403	599,025	2	1	5	5	7	19	2	10	14	53	37	1,136	11	165	
Meekatharra	20	15,299			1,240	364,182	1	1													
Menzies	2	21			933	252,476									1	1	4	10			
Mount Magnet	14	286			344	106,411	1	1							7	8	3	6			
Mount Malcolm	8	167			693	198,507									8	31	4	4			
Mount Margaret	1	24			1,266	368,314											3	3			
Mount Morgans	3	58			1,186	348,513															
Niagara	2	12			172	50,973											3	6			
Northampton	5	120			28	3,197															
(Private Property)					13	1,777															
Nullagine	5	120	12	2,330	898	144,311					2	2	3	4	2	5	15	49			
Peak Hill	7	99			503	137,054	1	1	2	2	2	8	2	5			1	10	6	144	
Phillips River					133	30,258					1	2	1	2					2	10	
(Private Property)					32	8,953															
South West	3	72	8	1,517	198	21,929													1	7	
(Private Property)	3	72	3	426	203	32,483															
Ularring	1	24			357	103,991					1	1	2	4			6	6			
West Kimberley	10	28,920	1	300	111	30,903					2	10					1	12	11	163	
West Pilbara	2	36	3	52	920	235,946	4	4	13	13					4	19	8	29	5	112	
Wiluna	1	24			1,209	356,671					1	1	1	3			5	1,325			
Yalgoo	5	108			1,196	340,512			6	2	1	5	1	5			1	10	1	24	
Yerilla	2	30			818	234,992											5	12			
Yilgarn	8	157			952	280,426	9	3	1	1					4	8			1	24	
(Private Property)	3	72			235	64,718															
Outside Proclaimed					3	468															
Totals	198	47,472	413	38,693	27,795	7,593,074	62	51	28	24	21	57	24	89	70	245	125	2,781	87	1,701	



TABLE 7

## MEN EMPLOYED

Average number of Men reported as engaged in Mining during 1970 and 1971

Goldfield	District	Gold		Other Minerals		Total	
		1970	1971	1970	1971	1970	1971
Kimberley							
West Kimberley				335	339	335	339
Pilbara	Marble Bar	2	3	510	540	512	543
	Nullagine	20	8	2	18	22	26
West Pilbara				793	977	793	979
Ashburton				332	305	332	305
Gascoyne		4		5	2	9	2
Peak Hill		1	2	529	867	530	869
East Murchison	Lawlers	6	6			6	6
	Wiluna	1				1	
	Black Range	2	2			2	2
Murchison	Cue		1				1
	Meekatharra	2	2	2		4	2
	Day Dawn						
Yalgoo	Mt. Magnet	116	116			116	116
			2	3	5	3	7
Mt. Margaret	Mt. Morgans		2				2
	Mt. Malcolm	3	2			3	2
	Mt. Margaret						
North Coolgardie	Menzies	2	2			2	2
	Ularring	1	1			1	1
	Niagara						
Broad Arrow	Yerilla	2	1			2	1
		3	5	136	412	139	417
North-East Coolgardie	Kanowna	3	4			3	4
	Kurnalpi	1				1	
East Coolgardie	East Coolgardie	1,488	1,372			1,488	1,372
	Bulong	2	2			2	2
Coolgardie	Coolgardie	4	4	1,264	1,475	1,268	1,479
	Kunanalling	3				3	
Yilgarn		23	9	98	100	121	109
Dundas		253	227		4	253	231
Phillips River				122		122	
South-West Mineral Field				1,713	1,945	1,713	1,945
Northampton Mineral Field				7	2	7	2
Greenbushes Mineral Field				80	103	80	103
Outside Proclaimed Goldfield				4	10	4	10
Collie Coalfield				635	623	635	623
<b>Total—All Minerals</b>		<b>1,942</b>	<b>1,775</b>	<b>6,570</b>	<b>7,727</b>	<b>8,512</b>	<b>9,502</b>

	1970	1971
<b>Minerals Other than Gold—</b>		
Alumina (from Bauxite)	1,165	1,374
Barytes	4	
Beryl	2	2
Building Stone	12	12
Bismuth	1	
Clays	19	12
Coal	635	623
Copper	122	20
Cupreous Ore (Fertiliser)	39	20
Felspar	6	11
Glass Sand	13	7
Gypsum	10	5
Iron Ore	2,183	2,754
Lead	7	2
Limestone	26	22
Manganese	22	24
Mineral Beach Sands	372	399
Nickel	1,381	1,861
Peat	5	2
Petroleum (Crude Oil)	166	108
(Natural Gas)		14
Salt	220	259
Semi-precious Stones	8	16
Talc	12	13
Tanto Columbite	3	3
Tin	137	164
Vermiculite		2
<b>Total, Other Minerals</b>	<b>6,570</b>	<b>7,727</b>

## PART 3—STATE AID TO MINING

### (a) State Batteries

At the end of the year there were 17 State Batteries including the Northampton Base Metal Plant.

From inception to the end of 1971, gold, silver, tin, tungsten, lead, copper and tantalite ores to the value of \$41,268,164 have been treated at the State Batteries. Included in the above amount is \$16,285,076 gold premium and \$210,703 premium paid by sales of gold by the Gold Producers Association Ltd. \$39,280,114 came from 3,656,573 tons of gold ore, \$470,834 from 84,016.35 tons of tin ore, \$39,366 from 4,143½ tons of tungsten ore, \$1,389,134 from 62,736½ tons of lead ore, \$11,932 from 220½ tons of copper ore and \$72,721 from 2,158½ tons of tantalite ore, and silver valued at \$4,063 recovered as a By-Product from the cyaniding of Gold Tailings.

During the year 27,985½ tons of gold ores were crushed for 9,914 oz. bullion, estimated to contain 8,402 oz. fine gold equal to 6 dwts. per ton. The average value of sands after amalgamation was 1 dwt. 15 gr. per ton, making the average head value 7 dwts. 15 gr. per ton. Cyanide plants produced 1,394 oz. fine gold, giving a total estimated production for the year of 9,796 oz. fine gold valued at \$343,228.

The working expenditure for the year for all plants was \$553,960 and the revenue was \$54,726 giving a working loss of \$499,234 which does not include depreciation, interest or Superannuation. Since the inception of State Batteries, the Capital expenditure has been \$1,878,931 made up of \$1,471,920 from General Loan Funds; \$322,195 from Consolidated Revenue; \$57,244 from Assistance to Gold Mining Industry; and \$27,572 from Assistance to Metalliferous Mining.

Head Office expenditure including Workers Compensation Insurance and Pay Roll Tax was \$87,668 compared with \$74,546 for 1970.

The actual expenditure from inception to the end of 1971 exceeds revenue by \$7,034,396.

### (b) Prospecting Scheme

At the end of the year 19 persons were in receipt of prospecting assistance as compared with 21 at the end of 1970.

Total Expenditure for 1971 was \$11,395 and refunds amounted to \$2,869.

Assisted prospectors crushed 461 tons of ore during the year for 216 oz. of gold.

Progressive total figures since the inception of the scheme are:

Expenditure \$1,026,916.

Refunds \$200,414.

Ore Crushed 125,693 tons

Gold Won 57,992 oz.

The rate of assistance remained at \$17.50 per man per week in the more remote localities and \$15.00 per man per week in the less isolated areas.

### (c) Geological Survey of Western Australia

The year 1971 was one of sustained activity in mineral exploration and again great demands on the services of the Geological Survey were made in providing regional geology, specialists services and information from the Survey's library and other records.

The scope of the advice and information available from the Branch is well known and its officers provide advice to the mining and allied industries where required, and advise on exploration and development of mineral production and water supplies.

## PART 4—GOVERNMENT CHEMICAL LABORATORIES

This Branch has wide functions covering both the governmental and private sectors of the community as the names of the Divisions indicate:

- (1) Agriculture Division.
- (2) Engineering Chemistry Division.
- (3) Foods, Drugs, Toxicology and Industrial Hygiene Division.
- (4) Industrial Chemistry Division.
- (5) Mineralogy, Mineral Technology and Geochemistry Division.
- (6) Water Division.
- (7) Kalgoorlie Metallurgical Laboratory.

The seventh Division was transferred to the Government Chemical Laboratories late in 1971 after being for many years an adjunct of the School of Mines, formerly under the administration of the Mines Department, but now part of the W.A. Institute of Technology. The Metallurgical Laboratory's main functions remain unaltered and are reported on by the Director in Division VI of this report.

## PART 5—EXPLOSIVES BRANCH

The Explosives Branch continued to carry out its normal functions of ensuring that the quality of explosives and their transport and storage together with flammable liquids complied with State requirements.

The year saw an increase in activity with licences under the Flammable Liquids Regulations alone rising from 3,900 in 1970 to 5,000 at the end of 1971.

The activities of the Branch are set out in detail in Division VII of this Report.

## PART 6—MINE WORKERS' RELIEF ACT AND MINERS' PHTHISIS ACT

Under arrangement with this Department the State Public Health Department continued the periodical X-ray examination of mine workers throughout the year.

A total of 10,683 examinations were made, of which 4,265 were made under the Mine Workers' Relief Act and 6,418 under the Mines Regulation Act. Of the latter, 5,989 were new applicants and 429 were re-examinees.

Compensation payments under the Miners' Phthisis Act amounted to \$9,712 compared with \$9,462 for the previous year. The number of beneficiaries under the Act as at 31st December, 1971, was 42 being 3 ex-miners and 39 widows.

## PART 7—SURVEYS AND MAPPING BRANCH

Surveys of mining tenements continued at a high level and 4,129 surveys were completed in 1971 at a cost of \$500,935 compared with 2,343 at a cost of \$292,306 in 1970. 41,272 applications were charted during the year compared with 28,024 in 1970.

## PART 8-STAFF

During 1971 the number of staff in the Registration Branch of the Department was increased which together with the introduction of some new methods helped considerably to cope with the accumulation of work created by the intense pegging activity of immediately preceding years.

However, it was still necessary for many members of the staff both in Perth and at numerous out-station Offices to work long hours of overtime in an endeavour to deal with the work situation.

I am pleased to record my sincere appreciation of the work done by all concerned.

In this summary I have referred only to specific items of the Department's functions. Detailed reports of the activities of each Branch are contained in Divisions II to VIII hereunder.

G. H. COOPER,  
Under Secretary for Mines.

Department of Mines,  
Perth.

## DIVISION II

# Report of the State Mining Engineer for the Year 1971

### *Under Secretary for Mines,*

I hereby submit the Annual Report for the State Mining Engineer's Branch, which is divided into the following sections—

#### Mineral and Metal Production—

by J. K. N. Lloyd, Assistant State Mining Engineer;

#### Mine Inspection and Accident Statistics—

by J. M. Faichney, Mining Engineer/Senior Inspector of Mines (Perth);

#### Petroleum Exploration and Production—

by A. J. Sharp, Petroleum Engineer;

#### Coal Mining—

by R. S. Ferguson, Mining Engineer/Senior Inspector of Coal Mines;

#### Drilling Operations—

by D. A. Macpherson, Drilling Engineer;

#### Board of Examiners—

by W. J. Cahill, Secretary, Board of Examiners.

### MINERALS, METALS AND OIL

The value of mineral and petroleum production in Western Australia for the year 1971 was \$646,660,150 compared with \$579,611,726 for the previous year.

The value of iron ore production was again the highest for the year at \$385,009,040 followed by nickel ore and concentrates valued at \$94,898,940, alumina at \$80,333,200 and crude oil at \$36,466,886. The decline in value of crude oil from \$53,710,900 for a similar production in 1970 was due to a reduction in price of Australian produced crude oil.

The Dongara natural gas field commenced production in October, 1971 and in December, 1971 was transmitting gas at an average rate of 26 million cu. ft. per day.

Gold production at 345,098 fine ounces was 5,292 ounces less than for 1970. The calculated value was higher at \$12,091,687 which included \$1,317,849 distributed by the Gold Producers Association representing \$3.79 per fine ounce for the gold sold.

### DRILLING

During 1971 the Drilling Section was responsible for the drilling of 26,204 feet in 82 bores and the test pumping of 46 bores.

Apart from drilling to investigate foundation conditions and obtain strata samples for harbour facilities at Wyndham, Port Hedland and Bunbury, the remainder was exploratory drilling for ground water which was mainly carried out in the De Grey River and Cooya Pooya surroundings in the North West and at Wiluna, Watheroo, Muchea, Gnangara and Gwelup.

### STAFF

#### Appointments—

G. J. Dodge, Mining Engineer—District Inspector of Mines	....	....	....	31-5-71
J. J. Zuvich, Mining Engineer—District Inspector of Mines	....	....	....	12-10-71
R. A. C. Williams, Mining Engineer—Special Inspector of Mines	....	....	....	15-10-71
D. Geldard, Ventilation Officer	....	....	....	17-5-71
A. D. Spencer, Workmen's Inspector of Mines	....	....	....	2-8-71
E. W. Jacobson, Workmen's Inspector of Mines	....	....	....	26-7-71
T. M. Sullivan, Workmen's Inspector of Mines	....	....	....	2-8-71

#### Resignation—

J. L. Hunt, Workmen's Inspector of Mines	....	....	....	4-3-71
--	------	------	------	--------

#### Retirement—

A. H. McGillivray, Workmen's Inspector of Mines	....	....	....	4-3-71
---	------	------	------	--------

A. Y. WILSON,  
State Mining Engineer.

### MINERAL AND METAL PRODUCTION

*J. K. N. Lloyd—Assistant State Mining Engineer*

Mineral production for the year 1971 is described in this report which is based on information obtained from various sources including the Statistical and Mines Inspection Sections of the Department.

Statistics relating to the mining industry are tabulated as follows:—

- Table 1—Mineral and Metal Output
- Table 2—Development Footages
- Table 3—Principal Gold Producers

TABLE 1  
Mineral and Metal Output

Product	1970		1971	
	Tons	Value	Tons	Value
Alumina	949,987·00	\$A 60,799,000	1,255,209·00	\$A 80,333,200
Asbestos	.....	.....	50·60	2,125
Barite	565·05	6,916	.....	.....
Bentonite	115·50	774	20·00	120
Beryl	15·55	5,797	63·42	17,703
Bismuth	1·69	6,867	.....	.....
Building Stone	6,616·50	69,781	11,920·00	142,728
Clays	184,818·55	229,293	164,848·48	118,124
Coal	1,197,733·50	5,827,291	1,171,623·64	5,734,353
Cobalt	332·73	1,197,680	202·43	801,560
Copper—				
Ore and Concentrates	2,978·20	662,762	1,990·92	283,322
Fertilizer Grade	603·99	126,890	428·13	52,643
Metal	2,095·66	2,037,360	939·04	998,400
Felspar	645·00	9,675	414·50	6,218
Glass Sand	95,569·00	34,046	172,963·14	82,927
Gold (fine ounces)	350,389·61	11,326,577	345,098·34	12,091,687
Gypsum	89,987·11	247,915	166,769·78	515,256
Ilmenite	550,660·15	5,984,389	690,495·07	7,940,866
Iron Ore	42,506,004·46	328,315,877	51,304,000·13	385,009,040
Iron Ore—Pig Iron	98,640·00	3,505,910	93,774·00	3,697,908
Lead Ore and Concentrates	456·59	64,779	40·16	3,899
Leucoxene	12,130·30	634,171	10,936·30	1,012,004
Limestone	1,168,849·67	1,246,403	1,284,680·05	1,373,218
Lithium Ore—Petalite	771·00	12,259	1,647·50	26,190
Magnesite	2,180·00	31,600	60·00	900
Manganese	202,373·50	3,743,921	123,308·00	2,138,974
Monazite	4,693·23	621,603	3,090·28	447,876
Nickel Ore and Concentrates	305,555·89	87,417,030	380,171·38	94,898,940
Ochre	608·54	6,085	.....	.....
Petroleum—				
Crude oil (barrels)	16,663,905·00	53,710,900	16,352,920·00	36,466,886
Natural Gas (1,000 cu. ft.)	.....	.....	1,221,221·00	158,759
Platinum (ounces Troy)	1,449·18	155,454	.....	.....
Pyrite	1,398·79	15,765	.....	.....
Rutile	2,251·61	200,483	218·75	29,008
Salt	1,815,935·62	6,476,489	2,370,378·00	7,622,123
Semi-precious Stones	32·26	45,224	123·79	91,560
Silver (fine ounces)	418,769·71	656,926	445,850·72	635,509
Talc	31,293·93	742,257	28,617·00	747,281
Tantalo-Columbite	68·58	246,510	73·85	383,650
Tin Concentrate	759·06	1,606,537	848·29	1,794,081
Vermiculite	299·42	1,797	54·10	325
Xenotime	55·00	71,922	56·00	73,921
Zircon	60,956·02	1,508,811	30,775·31	926,866
<b>Totals</b>	.....	579,611,726	.....	646,660,150

TABLE 2  
Development Footages Reported by the Principal Mines

Gold or Mineral Field	Mine	Decline and Shaft Sinking	Driving	Cross Cutting	Rising and Winzing	Exploratory Drilling	Total
		feet	feet	feet	feet	feet	feet
Gold—							
Murchison	Hill 50 Gold Mine N.L.	157	920	616	415	5,528	7,636
Dundas	Central Norseman Gold Corpn. N.L.	.....	82	.....	582	535	1,199
East Coolgardie	Gold Mines of Kalgoorlie (Aust.) Ltd.	.....	5,603	.....	2,231	7,827	15,661
	Lake View and Star Ltd.	.....	715	344	1,143	3,894	6,096
	<b>Totals in Gold Mines</b>	157	7,320	960	4,371	17,784	30,592
Nickel—							
Coolgardie	Western Mining Corpn. Ltd.	7,595	28,495	.....	10,285	275,060	321,435
	Metals Exploration N.L.	753	2,481	669	1,478	13,162	18,543
	International Nickel Aust. Ltd.	572	87	352	117	3,587	4,715
	Anaconda Australia Inc.	984	942	.....	.....	.....	1,926
Broad Arrow	Scotia (Great Boulder-North Kalgurli)	126	2,270	80	753	6,396	9,625
North Coolgardie	Carr Boyd Rocks (Great Boulder-North Kalgurli)	.....	2,333	804	477	6,695	10,309
	<b>Totals in Nickel Mines</b>	10,030	36,608	1,905	13,110	304,900	366,553
	<b>Totals in All Mines</b>	10,187	43,928	2,865	17,481	322,684	397,145

## ALUMINA

*Alcoa of Australia (W.A.) N.L.* railed 4,530,933 tons of bauxite to the Kwinana Refinery from its No. 2 mine at Jarrahdale. Alumina sales totalled 1,255,209 tons having an estimated value of \$80,333,200 f.o.b. Kwinana.

Mining at Jarrahdale covered 250 acres with faces ranging from 10 to 20 feet. Equipment is progressively being modernised with the replacement of shovels by four 992 Caterpillar rubber tyred loaders. Eight 35-ton capacity off highway trucks were placed in service during the year. Overburden removal is now handled by two new Caterpillar 955 loaders and 4 small off highway trucks. A new rail unloading terminal and associated storage tanks—for the handling of Pinjarra alumina—are under construction at Kwinana. The company employed an average of 1,374 personnel which included 188 at the mine site and the rest at the refinery.

Construction of the Pinjarra refinery continued throughout the year. Mine development is almost complete and test runs have been made with the crushing, conveying and stacking systems in January, 1972. A 450-ton self-propelled crushing unit incorporating a 1,200-ton per hour capacity jaw crusher has been installed. Thirty-five-ton capacity trucks will dump ore on to a large apron feeder situated within the unit. As areas are mined out the crusher will "walk" to new sites in the Darling Range and the conveyor system will be extended. Initially, the crushed ore will be fed onto the 20,500 feet long conveyor system linking the crusher to the stacking area at the refinery.

## ASBESTOS

Old dumps at Lionel were the source of fifty-one tons of chrysotile produced in the Pilbara. At present there are no groups actively engaged in developing Western Australian deposits of chrysotile or crocidolite.

## BENTONITE

A lake deposit at Marchagee was the source of the twenty tons produced during 1971.

## BERYL

Sixty-three tons, containing 713.09 units of beryllium oxide, valued at \$17,703 were obtained from claims in the Yalgoo, Coolgardie, Pilbara, Northampton and East Murchison Goldfields. Main producing centres were Rothsay with 462 units, Wydgee Station and Londonderry each with 88 units and Dalgara with 53 units.

## BUILDING STONE

Production from mining tenements, granted under the provisions of the Mining Act, was 11,920 tons valued at \$142,728. Production included 9,838 tons of crushed quartz from Mukinbudin, 1,269 tons of quartzite from Toodyay, 638 tons of granite facing stone from Watheroo, 145 tons of spongolite from Fitzgerald River and 30 tons of sandstone from Mount Barker. It is anticipated that deposits of marble and limestone, known to exist in the Ashburton, will be exploited in coming years.

## CLAYS

Reported clay production from the Metropolitan Area, Bullsbrook, Byford, Goomalling and Chandler totalled 164,848 tons valued at \$118,124.

## COAL

The total output from all mines in the Collie Coalfield was 1,171,624 tons valued at \$5,734,353 at the pit head. This output was 26,109 tons less than the previous years' record output of 1,197,733 tons.

The Muja open cut operated by the *Griffin Coal Mining Co. Ltd.* produced 611,754 tons of coal which represented 52.2 per cent. of the total output for the field. Overburden removed amounted to 2,906,063 cubic yards or 4.75 cubic yards of overburden removed per ton of coal produced.

*Western Collieries Ltd.*'s output of 559,870 tons was obtained from the Western No. 2 mine (408,380 tons) and Western No. 5 open cut (151,490 tons). Coal Mining operations at Collie are more fully covered in the report by the Senior Inspector of Coal Mines.

## COBALT

Two-hundred-and-two (202) tons of cobalt valued at \$801,560 were contained in nickel concentrates from Western Mining Corporation Ltd.'s operations at Kambalda and from the Great Boulder-North Kalgurli mine at Scotia.

## COPPER

*Ravensthorpe Copper Mines N.L.* ceased production at Ravensthorpe early in the year after working for 14 years during which time 798,334 tons of ore and 39,296 tons of old dumps were treated for a production of 55,835 tons of concentrate containing 11,869 tons of copper, 19,340 fine ounces of gold and 66,000 fine ounces of silver valued at \$8,000,000 f.o.b. Esperance. Sales of concentrate in 1971 amounted to 1,370 tons containing 219 tons of copper and 340 fine ounces of gold.

*Western Mining Corporation Ltd.* reported the production of 939 tons of copper contained in nickel concentrates from Kambalda.

At Ilgarari in the Peak Hill Goldfield, *Group Explorations Pty. Ltd.* sank two small exploration shafts and carried out development work on the 200 feet level. 340 tons of hand picked ore containing 87½ tons of copper valued at \$76,235 was shipped to Port Kembla for smelting.

Total production of ore for use as a trace element in fertilizers was 428 tons averaging 11.72 per cent. Cu and valued at \$52,643 on rail. The principal producer was *Thaduna Copper Mines Co. Pty. Ltd.* with 398 tons of 11.95 per cent. ore valued at \$50,175.

## FELSPAR

*Australian Glass Manufacturers Co.* reported the production of 414 tons from its quarry at Londonderry in the Coolgardie Goldfield. The company also obtained 1,647 tons of petalite from the same area.

## GLASS SAND

Glass sand production totalled 172,963 tons valued at \$82,927 which value does not include the value of 6,938 tons exported by *Ready Mix Concrete (W.A.) Pty. Ltd.* The major suppliers of glass sand were *Silicon Quarries Pty. Ltd.* at Jandakot with 116,550 tons, *Bell Bros. Pty. Ltd.* at Lake Gnangara with 31,808 tons and *Australian Glass Manufacturers Co.* at Lake Gnangara with 16,167 tons.

## GOLD

The ore treated during the year amounted to 1,675,109 tons as compared with 1,740,020 tons for the previous year. Gold recovered was 345,098 fine ounces which was 5,292 ounces less than the 1970 production. Grade of ore mined was higher, recovery being 4.12 dwts. per ton as compared with 4.03 dwts. for 1970.

The calculated value of the gold produced was \$12,091,687 which included \$1,317,849 distributed by the Gold Producers Association from the sale of 348,012 fine ounces of gold at an average premium of \$3.79 per fine ounce. The Mint value of gold throughout the year was \$31.25 per fine ounce.

Statistics relating to the gold mining industry are tabulated in Table "3".

*North Kalgurli (1912) Ltd.* now *North Kalgurli Mines Ltd.* treated 234,701 tons of ore for a recovery of 44,227 fine ounces of gold at an average recovery of 3.77 dwts. per ton. During the previous year 53,075 fine ounces were recovered from 288,550 tons.

Except for 492 feet of diamond drilling for the purpose of mine drainage no other development work was carried out in the mine. The average number of men employed during the year was 308.

*Central Norseman Gold Corporation N.L.* treated 140,634 tons for a recovery of 48,959 fine ounces of gold. Gold recovery was at the rate of 6.96 dwts. per ton as compared with the previous years' recovery of 6.74 dwts. per ton when 149,772 tons yielded 50,506 fine ounces. Ore reserves at the end of June were reported to be 232,700 tons at 8.2 dwts. per ton.

TABLE 3  
*Principal Gold Producers*

Mine	1970			1971		
	Tons Treated	Fine Ounces	Dwts. per ton	Tons Treated	Fine Ounces	Dwts. per ton
Gold Mines of Kalgoorlie (Aust.) Ltd. ....	815,322	130,155	3.19	825,593	135,467	3.28
Lake View & Star Ltd. ....	418,203	98,031	4.69	387,244	92,299	4.77
Central Norseman Gold Corporation N.L. ....	149,772	50,506	6.74	140,634	48,959	6.96
North Kalgurli (1912) Ltd. ....	234,701	53,075	3.68	234,701	44,227	3.77
Hill 50 Gold Mine N.L. ....	28,703	6,581	4.59	58,404	14,208	4.86
State Batteries ....	22,811	7,336	6.43	27,986	8,402	6.00
State Batteries Tailings Treatment ....	....	1,161	....	....	1,394	....
Other Sources ....	16,659	3,545	4.26	547	142	5.19
Totals in all Mines ....	1,740,020	350,390	4.03	1,675,109	345,098	4.12

*Gold Mines of Kalgoorlie (Aust.) Ltd.* with a production of 825,593 tons of ore for a return of 135,467 fine ounces of gold at an average recovery of 3.28 dwts. per ton was the States' leading producer. Production from the company's Fimiston leases was 137,580 tons yielding 34,604 fine ounces and from Mount Charlotte 688,013 tons yielding 100,863 fine ounces.

Ore reserves at the end of June were reported to be 469,000 tons at 4.8 dwts. for the Fimiston leases and 2,278,000 tons at 3.7 dwts. for Mount Charlotte. Development work completed during the year included 5,603 feet of driving and crosscutting, 1,410 feet of winzings and 821 feet of rising. The development at Fimiston was confined to the workings off the Perseverance Shaft while that at Mount Charlotte was mainly in "C" block below the No. 10 level. Ore drawn off from mill holes below the 10 level is carted by front end loaders to ramps where haulage trucks are filled and the ore then transported up the incline to the 9 level, for discharge into ore passes feeding into the underground crusher.

*Lake View and Star Ltd.* produced 92,299 fine ounces of gold from the treatment of 387,244 tons of ore at an average recovery of 4.77 dwts. per ton. The previous years' production was 98,031 fine ounces from the treatment of 418,203 tons. Ore reserves as at the 30th June, 1971 were estimated as 2,024,600 short tons at 4.71 dwts. per ton.

Most of the labour force of 568 men on the payroll was concentrated on the Horseshoe No. 2 and Lake View shafts the main producing mines. There has been a noticeable decrease in the number of men employed on the Chaffers, Ivanhoe and Associated Shafts. Surface works completed during the year included the construction of a new metallurgical laboratory and sample preparation plant.

The company has ceased level development work and is concentrating on mining the reserves as well as cleaning out broken ore from old stopes. Most of the years' production came from workings between the 900 feet and 3,250 feet levels of Regent Shaft.

*Hill 50 Gold Mine N.L.* at Mount Magnet treated 58,404 tons of ore for a return of 14,208 fine ounces of gold, average recovery being 4.86 dwts. per ton. This output was more than double that for the previous year when 6,581 fine ounces were recovered from the treatment of 28,703 tons. The company reported that ore reserves at the 22nd June totalled 715,500 tons at 5.3 dwts.

Development work completed during the year included 157 feet of shaft sinking, 920 feet driving, 616 feet crosscutting, and 415 feet rising. Development of the 909 feet level of the Morning Star mine has been completed and the internal shaft at Hill 50 has been advanced to 3,106 feet.

Smaller producers of note were the *Daisy* at Mount Monger with 1,592 fine ounces from 703 tons, *Kingsmill* also at Mount Monger with 727 fine ounces from 2,713 tons, *Constance Una* at Parkers Range with 702 fine ounces from 1,630 tons, *Middle Hannans* at Kalgoorlie with 576 fine ounces from 1,406 tons, and the *Radio* at Golden Valley in the Yilgarn with 373 fine ounces from 426 tons.

## GYPSUM

Plaster and cement manufacturers obtained their supplies of gypsum from Yellowdine (39,825 tons), Lake Brown (15,663 tons), Nukarni (1,203 tons), Lake Cowcoving (412 tons), Norseman (200 tons) and Kellerberrin (40 tons). *Garrick Agnew Pty. Ltd.* reported the export of 109,427 tons from Useless Loop in the Shark Bay area.

Total gypsum production for the year was 166,770 tons valued at \$515,256. Included in the total was 14,384 tons used in the manufacture of cement. Reported production of Plaster of Paris was 35,093 tons from 49,740 tons of gypsum.

ILMENITE, LEUCOXENE, MONAZITE, RUTILE, XENOTIME, ZIRCON

Sales of ilmenite totalled 690,495 tons valued at \$7,940,866. Minerals associated with ilmenite returned \$2,489,875 to the producers.

*Western Titanium N.L.* at Capel produced 241,914 tons of ilmenite assaying 54.55 per cent. titanium dioxide, 10,000 tons of upgraded ilmenite assaying 90.10 per cent. TiO<sub>2</sub>, 1,223 tons of leucoxene, 1,755 tons of monazite, 201 tons of rutile, 56 tons of xenotime and 8,894 tons of zircon. Early in the year production commenced from two new pits situated approximately half a mile south-east of the existing treatment plant. Bulldozers ripping and front end loaders operating on a load and carry basis dump ore into vibrating feeders which wash and screen out the large rocks and pump the sands to a mobile wet concentrator. The 250 tons per hour wet concentrator comprises 9 Reichert cones which produce a 95 per cent. or better heavy mineral concentrate. Area mined during the year totalled 37 acres with faces averaging about 15 feet high. Restoration of the old mining area beside the Bussell Highway continued.

*Western Mineral Sands Pty. Ltd.* at Capel produced 206,106 tons of ilmenite assaying 54 per cent. TiO<sub>2</sub>. There has been no major alteration to the mining method which continues as a sand excavation operation using front end loaders. The area mined amounted to 20 acres over an average face height of 25 feet. Seventeen acres were restored during the year and used for cattle grazing. All secondary mineral concentrates produced as a residue during ilmenite production were sold to Westralian Sands Ltd.

*Westralian Sands Ltd.* at Yoganup and Capel produced 136,659 tons of ilmenite assaying 56.59 per cent. TiO<sub>2</sub>, 5,482 tons of leucoxene, 1,295 tons of monazite, 18 tons of rutile and 20,286 tons of zircon. Mining by open cut methods on three benches with face heights of 18, 10 and 8 feet is still carried out by contractors in the company's open cut at Yoganup. The top face (18 feet) is above the water table and is mined by front end loader. The lower benches are now mined by a NCK Rapier Backacter. Late in the year a start was made on the construction of a new 200 ton per hour wet concentrating plant at a site just north of the Capel River.

*Ilmenite Minerals Pty. Ltd.* and *Cable (1956) Ltd.* wholly owned subsidiaries of *Kathleen Investments (Aust.) Ltd.* produced 95,716 tons of ilmenite, assaying 54.32 per cent. TiO<sub>2</sub>, 4,231 tons of leucoxene, 40 tons of monazite, and 1,596 tons of zircon. At Wonnerup, dry mining using a front end loader has replaced the dredge previously in use. Decreasing face heights (6 to 20 feet) and increasing quantities of rock forced the change in mining method. At Stratham, the suction dredge is still used on the deposit ranging from 20 to 60 feet in depth. During the year the company's restored 36 acres which is now used for grazing purposes.

IRON ORE

Total iron ore production for the year was 52,297,774 tons valued at \$388,706,948. This output represents a 22.75 per cent. increase on the 1970 output of 42,604,644 tons.

*Hammersley Iron Pty. Ltd.* exported 20,047,424 tons of 64.16 per cent. iron ore and pellets valued at \$159,184,575 f.o.b. Dampier. Included in the above total was 2,283,818 tons of pellets valued at \$23,421,906. This tonnage was obtained from 39 million tons of material excavated from the Tom Price deposit and included about 13 million tons of low grade ore and 5 million tons of waste.

To achieve the above production the company's pit operation is based on three only 8 hour shifts per day, six days per week. Basic equipment in use at the mine includes:—

- 4 only 12 cu. yd. Marion diesel electric shovels;
- 3 " 12 cu. yd. Marion electric shovels;
- 1 " 6 cu. yd. Marion diesel electric shovel;
- 25 " 100 ton Dart electric wheel trucks;
- 16 " 120 ton Wabco electric wheel trucks;
- 7 " 100 ton Dart diesel articulated trucks;
- 3 " 60R Bucyrus Erie rotary drills;
- 5 " RCD-930 Gardner Denver percussion drills;
- 13 " rubber tyred and track type dozers.

Construction projects at Paraburdoo and East Intercourse Island are expected to be completed early in 1972. Work in progress at Paraburdoo included pit development and the construction of a crushing and screening plant having a design capacity of 15 million tons per year. The 62 mile standard gauge railway extension from Tom Price to Paraburdoo was nearing completion at the end of the year. 136 lb. per yard rail has been used on this continuously welded track which was laid in 1,600 feet lengths on hardwood sleepers placed at a frequency of 3,250 per mile. Two interesting features of the railway project were the construction of a 540 foot span, trussed arch bridge—the largest railway bridge in Western Australia—over a 150 feet deep gorge and the construction of a 2,000 feet long by 130 feet deep box cut requiring the excavation of half a million cubic yards of rock.

Construction at East Intercourse Island included the construction of a rock causeway 6,422 feet long by 46 feet wide supporting portion of a 8,824 feet, 60 inch wide conveyor. Provision has been made to stockpile 2 million tons of ore on the island. The wharf designed to handle vessels up to 160,000 tons dead weight is 1,120 feet long carrying a 7,500 tons per hour capacity ship loader fitted with a 128 feet boom. The newly dredged shipping channel is 550 feet wide with a depth of 52 feet below dead low water.

At present the company employs 2,174 persons in the North-West with a further 3,000 being employed by contractors engaged on the expansion programme.

*Mount Newman Mining Co. Pty. Ltd.* exported 18,286,226 tons of 63 per cent. Fe iron ore which included 763,872 tons shipped to the Eastern States. The total value of the 1971 shipments was \$131,733,471 f.o.b. Port Hedland.

At the Mount Whaleback mine site 47.4 million tons of material was moved which included 24.7 million tons of waste and 4.3 million tons of low grade ore. A westerly extension of the ore body was developed as the ore body to the east is approaching the limit of values. The second crushing plant and train load-out tunnel at the mine were completed.



During the year 1,564 ore trains travelled from the mine and 295 ships were loaded at Nelson Point, Port Hedland. The tertiary crushing plant at Port Hedland was extended and it is expected that all work ancillary to the enlarged 4½ million ton capacity stockpile area will be completed early in 1972. Equipment at the port includes 2 stackers each with a capacity of 4,000 tons per hour, 2 reclaimers each rated at 3,500 tons per hour, and a shiploader which can load ore carriers at the rate of just over 6,000 tons per hour.

The company labour force of 2,035 includes 1,100 employees at Newman, 881 at Port Hedland and 54 on the ore railroad. The average number of personnel employed by contractors was not determined but were estimated to be not less than 3,000. Work continued on the upgrading of the 265 mile standard gauge railway which work included the provision of 13 main line sidings and an all welded track.

*Goldsworthy Mining Ltd.* reported the sale of 6,574,008 tons of iron ore assaying 63.78 per cent. Fe and valued at \$49,786,984 f.o.b. Port Hedland. Also fourteen million tons of waste was mined from the Mount Goldsworthy pit which is now about 3,800 feet long, 1,500 feet wide and 380 feet deep. Final pit level is expected to be 600 feet below plain level or 360 feet below sea level.

Major equipment at the mine includes:—

- 4 x 10 cu. yd. capacity P. & H. electric shovels;
- 1 x 7 cu. yd. capacity Bucyrus Erie electric shovel;
- 2 x 4½ cu. yd. capacity P. & H. diesel electric shovel;
- 12 x 108 ton capacity Haulpak rear dump trucks;
- 11 x 58 ton capacity Haulpak rear dump trucks;
- 6 x Bucyrus Erie 60R and 40R rotary drills.

At Finucane Island the stockpile area has been increased to take about ¾ million tons of crushed and screened ore. Mechanical equipment on the island includes 1 x boom stacker, 1 x stacker reclaimer, 2 x bucket wheel reclaimers and a shiploader having a capacity of about 3,000 tons per hour.

At present 490 persons are employed at Mount Goldsworthy and 160 at Finucane Island. About 40 men are employed on prospecting and evaluation of the Packsaddle deposit. A start has been made on construction and initial pit development at Shay Gap situated about 45 rail miles east of Goldsworthy. Eighty men are employed on this project.

*Dampier Mining Co. Ltd.* produced a total of 5,632,671 tons of iron ore averaging 64.44 per cent. Fe and valued at \$39,137,577.

Export overseas of Koolan Island ore amounted to 2,388,331 tons of 66.35 per cent. Fe ore valued at \$15,574,417. Shipments of Cockatoo Island ore to the Eastern States totalled 1,393,994 tons of 65.43 per cent Fe ore having a nominal value of \$9,757,958. In addition, 38,823 tons of ore from Cockatoo Island valued at \$251,076 was exported overseas. The company employed a total of 318 on the two islands throughout the year.

The Koolan deposit has been worked over a length of 6,000 feet and width of 600 feet to a depth of 160 feet at a waste to ore ratio 1.53:1. At Cockatoo the deposit forms a sea wall of the island and has been worked over a length of 5,500 feet and width of 200 feet to a depth of 340 feet or nearly sea level. Cockatoo ore produced at a waste to ore ratio of 0.22:1.

Koolyanobbing production was 1,811,523 tons averaging 61.11 per cent. Fe and having a nominal

value of \$13,554,126. Included in the production was 541,306 tons shipped to the Eastern States and 385,509 tons exported overseas from Kwinana. The remaining ore was the source of feed for the 600,000 ton per annum capacity blast furnace at Kwinana. Storage capacity for train loading at Koolyanobbing has been increased to 14,000 tons by the construction of an additional crushed ore bin. Full time employees at the mine totalled 77.

Western Mining Corporation Ltd. mining the Koolanooka Hills deposit near Morawa exported 663,671 tons of 59.97 per cent. Fe ore valued at \$5,166,433 f.o.b. Geraldton. Stock piling of crushed ore continued at the mine with production coming from the 1,035, 1,005, 975 and 945 foot benches. The plain level in the area is at approximately 1,030 feet and ground water now enters the northern end of the pit at a rate of about 4,000 gallons per hour. Work has commenced on opening up the Mungada deposit at Blue Hills some 37 miles east of the Koolanooka mine site.

*The Charcoal Iron and Steel Industry* at Wundowie obtained 93,774 tons of iron ore from the Koolyanobbing deposit situated about three miles east of the Dowds' Hill deposit worked by Dampier Mining. Pig iron production was 59,245 tons valued at \$3,697,908.

## LEAD

Mining operations in the Northampton Mineral Field were confined to the Ethel Maud Lead Mine in the Galena locality and the North Ellen at Northampton. The sale of 40.16 tons of concentrate containing 20.86 tons of lead returned \$3,899 to the producer.

## LIMESTONE

Reported production of limestone was 1,284,680 tons valued at \$1,373,218. Quarries for building stone continued to operate at Rockingham, Spearwood, Beaconsfield, Coogee and Wanneroo. Cement manufacturers obtained their supplies from Jandakot and South Coogee. Country sources of supply of limestone included Mount Many Peaks, Kojonup and Esperance.

## LITHIUM ORE

*Australian Glass Manufacturers Co.* obtained 1,647 tons of petalite from quarry operations at London-derry in the Coolgardie Goldfield.

## MAGNESITE

*Magnesite (W.A.) Pty. Ltd.* reported the sale of 60 tons obtained from the Phillips River Goldfield. Testing of the main deposit, 20 miles east of Ravens-thorpe, was in progress towards the end of the year.

## MANGANESE

Exports from Port Hedland totalled 118,029 tons averaging 46.04 per cent. Mn and valued at \$2,052,736. Horseshoe production exported by *Westralian Ores Pty. Ltd.* through Geraldton amounted to 10,279 tons of 35 per cent. Mn ore valued at \$86,238.

In the Pilbara the two producers were *Westralian Ores Pty. Ltd.* with 91,557 tons of 46.88 per cent. Mn ore obtained in the Nullagine district, and *Dampier Mining Co. Ltd.* with 26,472 tons from Nullagine and Woodie Woodie. At present *Longreach Manganese Pty. Ltd.* is testing ferruginous manganese deposits at Ripon Hills.

## NICKEL

Nickel ore and concentrate production from the Coolgardie and Broad Arrow Goldfields amounted to 380,171 tons having an estimated f.o.b. value of \$94,898,940.

*Western Mining Corporation Ltd.* reported the sale of nickel contained in 278,843 tons of 11.49 per cent. Ni concentrate and having an estimated value of \$86,219,100. This output included nickel briquette and powder production from the company's nickel refinery at Kwinana which is operating at its design rate of 15,000 tons per year.

At Kambalda the company treated 1,084,653 tons of ore which included ore purchased from Metals Exploration N.L. mining at Nepean. Ore reserves were reported to be 20,556,000 tons averaging 3.4 per cent. nickel. Development completed during the year included 637 feet of shaft sinking, 6,958 feet of decline construction, 28,495 feet of driving and cross-cutting, 7,208 feet of raise drilling, 2,884 feet of rising and 193 feet of winzing.

The Silver Lake shaft was deepened to 1,100 feet with sinking continuing at the close of the year. Most of the stopes off this shaft are worked by the slot method but an increasing number of flat back hydraulic fill stopes are being introduced. At the Durkin Shaft the No. 5 level is being developed and sinking of the haulage shaft continued to below the No. 8 level.

The decline servicing the Otter and Juan shoots was extended to develop the No. 5 level and work on the decline is continuing at an inclined depth of about 900 feet below the No. 5. Stopping widths in this area are generally in the order of 8 feet although one section of the Juan shoot has been mined to a width of 40 feet. Diesel powered haulage equipment and Jumbo drilling rigs are a feature of the mining method. Early in the year a start was made on construction of portals and declines servicing the McMahon and Fisher shoots. Both declines were advanced at a steady rate and at the end of the year had reached 1,400 feet and 800 feet respectively.

The Scotia operations of the *Great Boulder Mines Ltd.* and *North Kalgurli Mines Ltd.* partnership produced 19,109 tons of 10.91 per cent. nickel concentrate valued at \$5,681,800 f.o.b. Esperance. Ore hoisted during the year amounted to 120,482 tons. Nickel sulphide ore reserves were reported as 1½ million tons averaging 2.25 per cent. nickel. Development completed during the year included 126 feet of shaft sinking, 2,270 feet of driving, 80 feet of crosscutting and 753 feet of rising.

At Carr Boyd Rocks the partnership completed 2,333 feet of driving, 804 feet of crosscutting and 477 feet of rising and winzing. Sulphide ore reserves are now estimated to be 1,800,000 tons averaging 1.41 per cent. nickel and 0.40 per cent. copper.

*Metals Exploration N.L.* at Nepean produced 82,219 tons of ore averaging 2.23 per cent. nickel and valued at \$2,998,040. The ore was treated at Western Mining's concentrator at Kambalda. Development work completed during the year included 181 feet of shaft sinking to 704 feet, 572 feet of decline construction (1 in 8) in two headings from the 420 feet level, 2,481 feet of driving, 669 feet of crosscutting, 336 feet of winzing and 1,142 feet of rising. Most of the production came from the 420 feet level No. 2 and the newly developed No. 3 sills. At this mine stopes are mined on the rill system using hand held machines and surface gravel for fill.

In the Mount Margaret Goldfield, *Poseidon Ltd.* completed a surface winze to 400 feet with 170 feet of crosscutting at the bottom and has advanced one decline (16 ft. x 14 ft. cross section) to 1,195 feet at a grade of 1 in 9.

*International Nickel Aust. Ltd.* in partnership with *Broken Hill Pty. Ltd.*, completed construction at Mount Edwards of shaft (19 ft. 4 in. x 11 ft. 1½ in. min.) to 970 feet. Plats were established on the 200, 400, 600 and 800 feet horizons and some level development carried out on the 600 feet level to obtain bulk samples for metallurgical investigation.

*Anaconda Australia Inc.* continued shaft sinking at Redross and Wannaway. The shaft at Redross is now down to 703 feet and at Wannaway 450 feet. Ore reserves remain as reported last year.

*Selcast Exploration Ltd.* commenced shaft sinking at Spargoville. The shaft now at 335 feet consists of 3 compartments, 2 only 6 ft. x 6½ ft. and 1 only 6 ft. x 5½ ft. inside dimensions.

## PETROLEUM

Shipments of Barrow Island crude oil totalled 16,352,920 barrels having an estimated value of \$36,466,886 at Kwinana. The construction of a 260 mile long 14 inch diameter pipeline between Dongara and Pinjarra was completed and commenced transmission of natural gas in October. Production to the end of the year was nearly 1¼ thousand million cubic feet valued at \$158,759 at the well head. Major offshore discoveries of gas were made at Scott Reef and north of Dampier. The report of the Petroleum Engineer covers more fully the activities of the companies engaged in the search and production of oil and gas.

## SALT

Production reported to the Department of Mines was 2,370,378 tons having an estimated f.o.b. value of \$7,622,123.

*Texada Mines Pty. Ltd.* operating at Lake MacLeod exported 1,588,021 tons through its port facility at Cape Cuvier. Ships can be loaded at the rate of 2,000 tons per hour. The potash pilot plant operated for a short period with encouraging results.

*Leslie Salt Co.* employing 45 persons at Port Hedland exported 642,462 tons. It is expected that this production rate will be maintained in 1972.

At Lake Lefroy, *Lefroy Salt Pty. Ltd.* has commenced the construction of a series of ponds on the lake bed.

## SEMI PRECIOUS STONE

Wingelina in the Warburton Mining District was the source of 66 tons of chrysoprase valued at \$65,976. Other semi precious stones, amethyst, moss opal and chalcedony valued at \$25,584 were obtained from deposits in the Gascoyne and at Norseman.

## SILVER

Silver production as a by-product of gold and lead mining amounted to 445,851 fine ounces valued at \$635,509.

## TALC

*Three Springs Talc Pty. Ltd.* operating an open-cut near Three Springs produced 28,617 tons of talc valued at \$747,281.

**TANTALO-COLUMBITE**

Seventy-four tons of concentrate containing 2,759 units of Ta<sub>2</sub>O<sub>5</sub> valued at \$383,650 were produced during 1971. Most of this production was from the Greenbushes field with *Greenbushes Tin N.L.* contributing 33 tons of concentrate containing 1,735 units and *Vultan Minerals Ltd.* with 862 units from 36 tons of concentrate. Other producing centres were Dalgarranga in the Yalgoo Goldfield and Marble Bar in the Pilbara.

**TIN**

Production for the year was 848 tons of concentrate containing 594 tons of tin valued at \$1,794,081. Output of concentrate from the Pilbara was 515 and from Greenbushes 333 tons.

*Pilbara Tin Pty. Ltd.* at Moolyella in the Pilbara was the State's leading producer with 294 tons of concentrate valued at \$630,290. It is expected that output will increase as the company has recently completed the erection of a new concentrating plant capable of treating ½ million cubic yards of wash per year.

Other notable producers in the Pilbara were *J. A. Johnston & Sons Pty. Ltd.* at Eleys with 96 tons of concentrate, *Cooglegong Tin Pty. Ltd.* at Cooglegong with 38 tons and *Westos Minerals Pty. Ltd.* at Coodina with 20 tons.

In the Greenbushes field *Greenbushes Tin N.L.* reported the production of 247 tons of concentrate valued at \$523,965. At the same centre *Vultan Minerals Ltd.* produced 82 tons of concentrate valued at \$166,799.

**VERMICULITE**

Mount Palmer in the Yilgarn was the source of 54 tons of vermiculite mined by *Mineral By-Products Pty. Ltd.*

**MINE INSPECTION AND ACCIDENT STATISTICS**

*J. M. Faichney—Mining Engineer and Senior Inspector of Mines (Perth)*

**ACCIDENT STATISTICS**

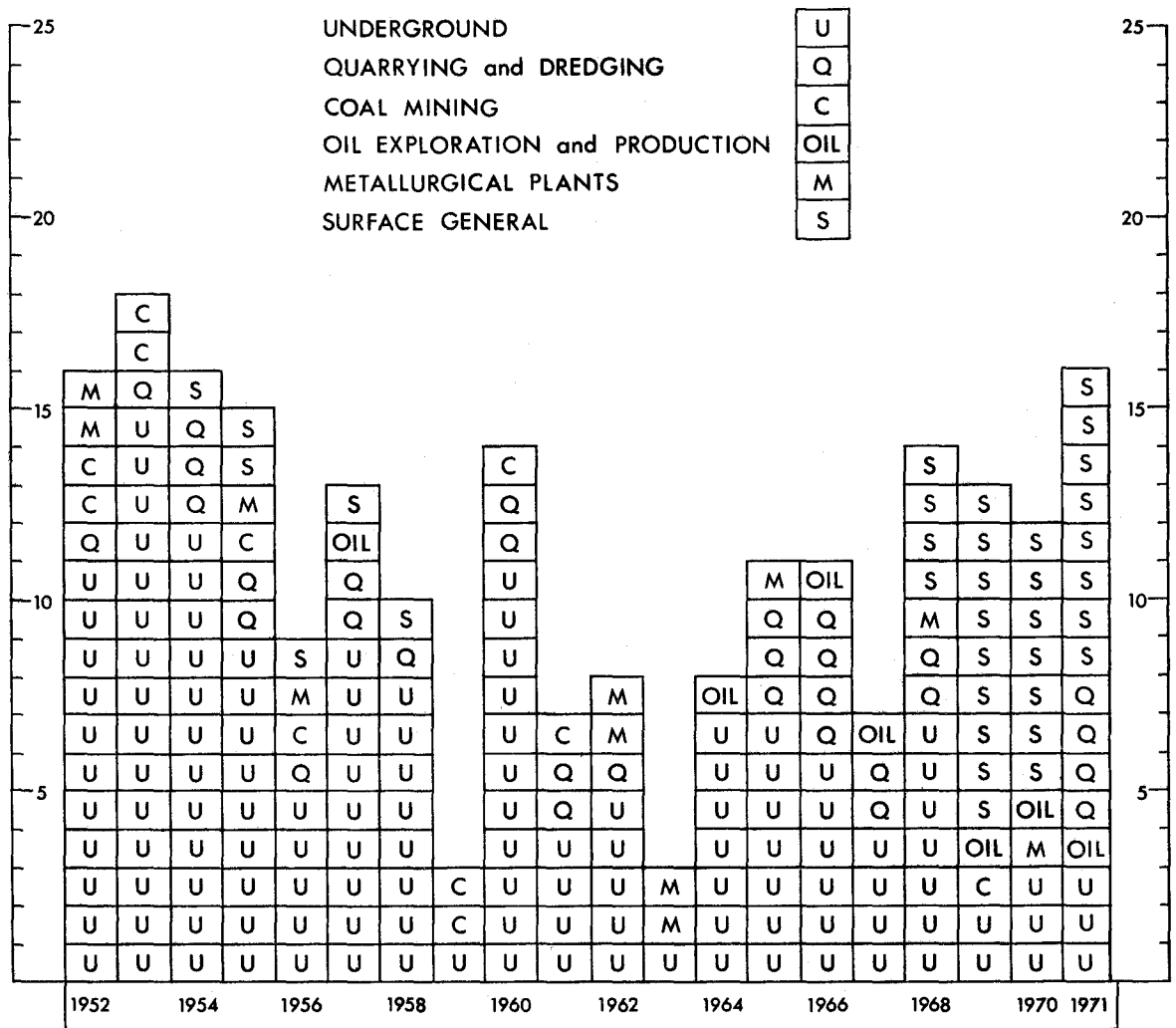
The number of fatal and serious mining accidents reported to the Mines Department for the year 1971 are tabulated below, and where relevant the corresponding figures for the previous year are shown in brackets.

Although classed as "mining" accidents, many of these were in fact "construction" accidents as they occurred in building and construction work on mine sites.

There were 16 (12) fatal and 428 (312) serious accidents reported for the year.

The diagram of Fatal accidents shown hereunder illustrates the fatal mining accidents which have occurred yearly over the past 20 years. These are classified according to the Category of mining operation.

**DIAGRAM OF FATAL ACCIDENTS  
SEGREGATED ACCORDING TO CLASS OF MINING**



FATAL ACCIDENTS.

Hereunder are brief descriptions of fatal accidents occurring during the year.

Name and Occupation	Date	Mine	Details and Remarks
Mack, C. A. (Diving Supervisor)	15/1/71	W.A. Petroleum Pty. Ltd.—Charlotte No. 1 Well (off-shore)	The deceased was working on the deck of a supply vessel supervising operations to remove a well head from the sea bed. A large wave inconsistent with the sea running at the time, hit the ship resulting in a large force being placed on the well head recovery chain/cable system. This parted and he was struck by the whipping cable and chain.
Vinci, A. (Truck driver)	18/2/71	Limestone quarry off Quinn's Rocks Road (L. & A. Vinci)	He was engaged in splitting a large limestone rock when a section of the face collapsed and covered him.
Prosenyak, G. (Skipman)	16/3/71	Western Mining Corporation Ltd. (Kambalda Nickel Operations) Durkin Shaft	He was travelling alone in a cage and it is possible that he struck his head on a steel girder at about the 300 feet level as the cage ascended.
Muntz, J. M. (Plant Assistant)....	20/3/71	Pioneer Quarries (W.A.) Pty. Ltd.—Salmon Gums	He fell from the crushed metal stockpile into the conveyor belt feed hole and was buried with crushed metal.
Lalic, P. (Labourer)	12/4/71	Hamersley Iron Pty. Ltd.—Contractor—M.K.M.O.	Riding as passenger on fork lift. He fell and was run over by wheel.
Jaceglav, J. (Miner)	24/5/71	Western Mining Corporation Ltd. (Kambalda Nickel Operations) Durkin Shaft	Death was due to compound fracture of the skull received when a scraper hoist moved forward after the anchors released when the hoe jammed.
Atkinson, T. R. (Truck driver)....	4/6/71 died 5/6/71	Hamersley Iron Pty. Ltd.	Whilst driving a 100 ton loaded Dart truck it ran off the haul road and deceased was thrown out. The accident occurred at night in poor weather conditions when preparing to pass an approaching Dart truck.
Cook, H. H. (Electrician)	29/6/71 died 4/7/71	Calsil Bricks Pty. Ltd.	Cook fell from the bucket of a front end loader being used to raise him from the ground to the cross arm of a pole whilst stringing an aerial cable.
Beckman, A. (Electrician)	2/7/71	Hamersley Iron Pty. Ltd.	Electrocuted when checking hoist motor of overhead crane. He made contact with live wires of motor heater circuit thought to have been isolated.
Flynn, J. J. (Fitter)	7/7/71	Alcoa of Aust. (W.A.) Ltd. at Pinjarra — Contractor — Carina Construction Pty. Ltd.	A heavy section of a filter frame fell on him as he was endeavouring to connect up a hydraulic ram opening mechanism.
Majetic, P. (Miner)	13/8/71 died 21/8/71	Gold Mines of Kalgoorlie (Aust.) Ltd. Perseverance Shaft	He received injuries in an explosion when "lighting up" in a stope
Grose, G. (Truck driver)	14/8/71	Cliffs W.A. Mining Co. Pty. Ltd. — Contractor — Harbour Works Clough	Struck by pile blank (36 in. diameter pipe) falling from his truck during offloading.
Symonds, T. (Serviceman)	17/8/71	Cliffs W.A. Mining Co. Pty. Ltd. — Contractor — Thiess Bros.	Crushed between D.9 bulldozer and service vehicle when the service vehicle reversed as the deceased was greasing the D.9 at night.
Munday, D. (Leading hand—workshop)	23/8/71	Texada Mines Pty. Ltd.—Contractor—Bell Bros. Pty. Ltd.	Crushed when truck fell from jack as new front spring was being fitted.
Robertson, J. M. (Loader operator)	12/11/71	Mt. Newman Mining Co. Pty. Ltd.	Driving 922B Cat. loader down main haul road and failed to negotiate "T" junction. The loader overturned on embankment crushing deceased in the cab.
Rhodes, P. J. (Track labourer)....	10/12/71	Mt. Newman Mining Co. Pty. Ltd. Railway about 77 mile peg	Engaged in drilling sleepers <i>in situ</i> for insertion of additional dog spikes and was struck by ballast waggon of train being propelled.

Table "A" shown hereunder gives a classification of the serious accidents according to the nature of the injury and the mining district in which the accident occurred.

In Table "B" accidents are segregated according to the mineral mined and processed giving the numbers of men employed. The employment figures include those engaged in construction work.

In gold mines there were 1 (4) fatal and 176 (116) serious accidents with an accident rate per 1,000 men of 0.51 (1.85) fatal and 89.70 (53.78) serious.

In nickel mines there were 2 (2) fatal and 21 (58) serious accidents. The accident rate per 1,000 men was 0.88 (1.45) fatal and 9.27 (42.00) serious.

In iron mines there were 7 (4) fatal and 91 (38) serious accidents with an accident rate per 1,000 men of 1.21 (0.80) fatal and 15.75 (7.62) serious.

There were also fatal accidents in bauxite 1 (—), salt 1 (1), rock quarries 1 (—), other minerals (lime stone and sand) 2 (—) and oil 1 (1).

Table "C" shows the fatal and serious accidents classified according to the accident causes and to the mining districts in which the accidents occurred.

#### WINDING MACHINERY ACCIDENTS

There were 14 accidents involving winding machinery reported during the year and consisted of one derailment, three overwinds, three involving the hangup of a cage or skip in a shaft and seven were classed as miscellaneous.

The derailment occurred in the underlay Regent Shaft of Central Norseman Gold Corporation N.L. due to a stone on the rails but no damage resulted.

Three overwinds were in vertical shafts. One was at Kambalda where the skip reached the overwind limit switch causing the safety devices to operate. The other two were on the Oroya Shaft of Gold Mines of Kalgoorlie (Aust.) Ltd. There was no serious damage.

The Cage/Skip hangups were in vertical shafts and resulted in some damage to shaft timbers, skips and equipment requiring repairs, and replacement of skips. On one occasion it was necessary to cut ten feet off the winding rope and recap it.

The miscellaneous accidents occurred principally during shaft sinking, or associated operations where kibbles with monkey were the principal vehicle for haulage of rock. Only minor damages occurred to the monkey, the monkey stops, or the shaft timber. In one incident the chain suspending a concrete kibble under a permanent kibble broke allowing the concrete kibble to fall until it jammed in the shaft sets. It is believed that a build up of cement on one side of the concrete kibble caused the kibble to be suspended in the shaft out of plumb during hoisting, allowing a projecting section of it to strike the shaft sets.

In all cases repairs, replacement, modification and the cutting and recapping of ropes was carried out to ensure compliance with safety requirements.

#### DECLINE AND SHAFT ACCIDENTS

The following accidents associated with main haulage ways and equipment were reported:—

Two separate falls of ground occurred during the driving of the Main Decline at the Windarra Project

of Poseidon Ltd. After the first fall steel sets were erected at intervals of not more than 4 feet apart. Another fall about five months later damaged several sets. Further falls occurred during the cleaning up and it was necessary to drill a hole from the surface and pour cement in behind a brattice erected in the decline and so consolidate the incompetent ground. A pilot heading was commenced through the cemented ground.

The supports under the ore bin at the operation of Selcast Exploration Ltd.—Spargoville, collapsed and the bin slumped on to the ground and the sky shaft. Parts of the sky shaft were damaged and had to be replaced. One man suffered a serious injury.

#### PROSECUTIONS

There were successful prosecutions of eight persons for working underground for more than six shifts in a week, for more than thirteen consecutive days in a fortnight, and for more than seven and one-half hours in a day. The Mine Manager was also successfully prosecuted for employing men to work underground for hours in excess of those laid down.

An unsuccessful complaint was made against a person for working as a shift boss without having a Underground Supervisor's Certificate. When this complaint was dismissed the complaint against the Mine Manager for employing an uncertificated shift boss was withdrawn.

#### SUNDAY LABOUR PERMITS

Twenty-four permits to employ labour underground in mines on Sunday were issued. One application was refused.

Four permits were granted to Gold Mines of Kalgoorlie (Aust.) Ltd. to prevent loss of time to normal production and included repairing a grizzly at an ore pass used by the Transloader, lowering a Euclid truck underground, completing work of installing a steel bearer and concreting a ramp, and completing a permanent brattice where the ore pass passes through the 900 level.

Western Mining Corporation Ltd. (Kambalda Nickel Operations) were given eight permits for such work as removing penthouses from shafts (Durkin and Silver Lake), completing repairs and maintenance to grizzly, replacing control chute at ore pass, shot creting the walls of the Fisher Decline, connecting up an electricity substation, and repositioning the grab hoist on the sinking stage.

A permit was issued to Anaconda Aust. Inc. to resecure the plat bearers in hitches at the 200 feet level of the Wannaway shaft.

International Nickel Aust. Ltd. had a permit to concrete the bearer set at the 800 feet level.

Metals Exploration N.L. needed a permit to work on a Sunday to break through to the shaft from the winder chamber on the 420 feet level of the Nepean Mine.

Poseidon Ltd. were given four permits to carry out shot creting of the back and walls of the Main decline, to install an electric pump, and diamond drill ahead of the face to determine the best position for safe development.

Great Boulder Mines Ltd. were issued with a permit to install a ventilation duct in the shaft at their Carr Boyd operations.

TABLE "A"  
Serious Accidents for 1971

Class of Accident	Kimberley	West Kimberley	Pilbara	West Pilbara	Peak Hill	Murchison	North Coolgardie	Broad Arrow	East Coolgardie	Coolgardie	Dundas	Greenbushes	South-West	Collie	Yilgarn	Mount Margaret	North-East Coolgardie	East Murchison	Ashburton	Total
<i>Major Injuries (exclusive to fatal)</i>																				
<i>Fractures—</i>																				
Head				1	2															3
Shoulder																				1
Arm	1		3	2	2								1							11
Hand			1	4	1			1	1	2			2	1						14
Spine	1												1							2
Rib		1											1							8
Pelvis			2	1									1	2						3
Thigh			1																	1
Leg			1	4	3			1		1			5							15
Ankle			1						2	1			3							7
Foot		1	4	6				1	1	1			1	1						16
<i>Amputations—</i>																				
Arm																				
Hand																				
Finger		1		2						3			5	1		1				13
Leg									1											1
Foot																				
Toe										1										1
Loss of Eye																				
Serious Internal Hernia									4	3										9
Dislocations		1		2						1			2	1						5
Other Major			1	9	1					1			2							14
<b>Total Major</b>	<b>2</b>	<b>4</b>	<b>14</b>	<b>34</b>	<b>9</b>			<b>3</b>	<b>9</b>	<b>15</b>			<b>26</b>	<b>6</b>		<b>2</b>				<b>124</b>
<i>Minor Injuries</i>																				
<i>Fractures—</i>																				
Finger				2					2	1			5	3						13
Toe			2	1				1	2				3	2						11
Head		1	1	1			1		6	3	1		3							17
Eye								1	3	2			3							10
Shoulder			1	1					4	1				2				1		10
Arm			2	2			1		4	1			2	3						15
Hand	1	1	2	1		2			16	10	1	1	11	1						47
Back		2		2					12	13	5		17	7	1					61
Rib										1			1							2
Leg				1	1	1			22	16	1		12	1			1			59
Foot	1			2			1		6	5	1		6	1						23
Other Minor	1	1	4	8		1			7	2			2	7		1			2	36
<b>Total Minor</b>	<b>3</b>	<b>5</b>	<b>10</b>	<b>22</b>	<b>2</b>	<b>5</b>	<b>4</b>	<b>1</b>	<b>83</b>	<b>57</b>	<b>9</b>	<b>3</b>	<b>65</b>	<b>27</b>	<b>1</b>	<b>2</b>	<b>1</b>	<b>1</b>	<b>3</b>	<b>304</b>
<b>Grand Total</b>	<b>5</b>	<b>9</b>	<b>24</b>	<b>56</b>	<b>11</b>	<b>5</b>	<b>4</b>	<b>4</b>	<b>92</b>	<b>72</b>	<b>9</b>	<b>3</b>	<b>91</b>	<b>33</b>	<b>1</b>	<b>4</b>	<b>1</b>	<b>1</b>	<b>3</b>	<b>428</b>

There were no serious accidents reported in the following Goldfields:—Northampton, Yalgoo, Gascoyne, Phillips River, Nabberu, Warburton and Eucla.

Table 'B' shows the fatal, serious and minor accidents reported and the number of men employed, classified according to the mineral mined.

TABLE B  
Accidents Segregated According to Mineral Mined and Processed

Mineral	Men Employed	Accidents		
		Fatal	Serious	Minor
Bauxite (Alumina) .....	1,374	1	53	220
Coal .....	623	.....	33	185
Copper .....	22	.....	1	.....
Gold .....	1,962	1	176	344
Gypsum .....	8	.....	.....	.....
Ilmenite etc .....	399	.....	6	60
Iron .....	5,779	7	91	376
Lead .....	15	.....	.....	.....
Manganese .....	24	.....	1	.....
Nickel .....	2,265	2	21	364
Oil (Production and Exploration) .....	520	1	29	37
Salt .....	285	1	1	21
Tin .....	164	.....	5	17
Other Minerals .....	227	2	2	.....
Rock Quarries .....	253	1	9	32
Totals .....	13,920	16	428	1,656

Table 'C' shows the fatal and serious accidents classified according to the accident causes and also shows the different Mining Districts in which the accidents occurred.

TABLE C  
Fatal and Serious Accidents showing Causes and Districts

District	Explosives		Falls		Shafts		Fumes		Miscellaneous Underground		Surface		Total	
	Fatal	Serious	Fatal	Serious	Fatal	Serious	Fatal	Serious	Fatal	Serious	Fatal	Serious	Fatal	Serious
Kimberley .....	.....	.....	.....	.....	.....	.....	.....	.....	.....	.....	.....	.....	.....	.....
West Kimberley .....	.....	.....	.....	.....	.....	.....	.....	.....	.....	.....	9	.....	.....	9
Pilbara .....	.....	.....	.....	.....	.....	1	.....	.....	.....	.....	1	23	1	24
West Pilbara .....	.....	.....	.....	.....	.....	.....	.....	.....	.....	.....	5	56	5	56
Ashburton .....	.....	.....	.....	.....	.....	.....	.....	.....	.....	.....	.....	3	.....	3
Peak Hill .....	.....	.....	.....	.....	.....	.....	.....	.....	.....	1	1	10	1	11
Gascoyne .....	.....	.....	.....	.....	.....	.....	.....	.....	.....	.....	1	.....	1	.....
Murchison .....	.....	.....	.....	.....	.....	.....	.....	.....	.....	3	.....	2	.....	5
East Murchison.....	.....	.....	.....	.....	.....	.....	.....	.....	.....	.....	.....	1	.....	1
Yaloo .....	.....	.....	.....	.....	.....	.....	.....	.....	.....	.....	.....	.....	.....	.....
Northampton .....	.....	.....	.....	.....	.....	.....	.....	.....	.....	.....	.....	.....	.....	.....
Mount Margaret .....	.....	.....	.....	1	.....	.....	.....	.....	.....	.....	.....	3	.....	4
North Coolgardie .....	.....	.....	.....	1	.....	.....	.....	.....	.....	.....	.....	2	.....	4
Broad Arrow .....	.....	.....	.....	.....	.....	.....	.....	.....	.....	.....	.....	1	.....	4
North-East Coolgardie.....	.....	.....	.....	.....	.....	.....	.....	.....	.....	.....	.....	1	.....	1
East Coolgardie .....	1	.....	.....	10	.....	.....	.....	.....	.....	.....	.....	48	1	92
Coolgardie .....	.....	3	.....	3	1	5	.....	.....	1	42	.....	19	2	72
Yilgarn .....	.....	.....	.....	.....	.....	.....	.....	.....	.....	.....	.....	1	.....	1
Dundas .....	.....	.....	.....	1	.....	.....	.....	.....	.....	4	1	4	1	9
Phillips River .....	.....	.....	.....	.....	.....	.....	.....	.....	.....	.....	.....	.....	.....	.....
Greenbushes .....	.....	.....	.....	.....	.....	.....	.....	.....	.....	.....	.....	3	.....	3
South West .....	.....	1	.....	.....	.....	.....	.....	.....	.....	.....	4	90	4	91
Collie .....	.....	.....	.....	.....	.....	.....	.....	.....	.....	24	.....	9	.....	33
Nabberu .....	.....	.....	.....	.....	.....	.....	.....	.....	.....	.....	.....	.....	.....	.....
Warburton .....	.....	.....	.....	.....	.....	.....	.....	.....	.....	.....	.....	.....	.....	.....
Eucla .....	.....	.....	.....	.....	.....	.....	.....	.....	.....	.....	.....	.....	.....	.....
Total for 1971 .....	1	4	.....	16	1	6	.....	.....	1	126	13	276	16	428
Total for 1970 .....	.....	3	.....	19	1	6	.....	.....	3	137	8	147	12	312

To concrete behind timber sets and to continue shaft sinking through clay material made mobile by an inflow of water two permits were granted to Metals Exploration N.L. at their Mt. Keith operations.

#### AUTHORISED MINE SURVEYOR

One Certificate for an Authorised Mine Surveyor was issued during the year.

#### CERTIFICATE OF EXEMPTION

(Section 46 of the Mines Regulation Act)

None were issued.

#### PERMITS TO FIRE OUTSIDE PRESCRIBED TIMES

Permits were issued to Western Mining Corporation Ltd. (Kambalda Nickel Operations) in respect of: the Durkin Haulage Shaft subject to maintaining a separate independent exhaust ventilation system; the Fisher and McMahon Declines subject to any conditions relating to road closure required by the Coolgardie Shire Council; the Juan Decline subject to a warning notice being displayed near the entrance, all miners at the Durkin and Area 8 mines being told personally of the permission, fumes being exhausted direct to the surface, and precautions being taken to ensure that nobody entered the area adjacent to the face during firing.

#### PERMITS TO RISE

Permits for the construction of 27 rises totalling 3,147 feet were issued. Only seven of the rises (1,185 feet) were risen by conventional methods the others using the rising gig (or stage) method. The seven rises made with the conventional method were at Central Norseman Gold Corporation N.L. where the average slope of the rises was 32°. These rises were for evaluation purposes. The other rises were principally for development but four were for ventilation.

#### VENTILATION

Inspections of the underground workings of all metalliferous mines throughout the State were made to record temperatures and obtain dust counts at the working places. A general appreciation of the prevailing condition and observation of the primary and secondary airflows was made. Some measurements of the airflows circulating through the mines were obtained and assistance was given to some operators to help overcome ventilation difficulties and eradicate dust control problems. Most crushing and screening plants in the State were inspected.

There was a decrease in the number of dust samples made in the year to 1,073 as compared with 1,247 in the previous year. The figures include samples from both surface and underground. The average count was 306 particles per cubic centimetre. This is a higher average dust count than for the previous year and is due to higher counts from a larger number of samples obtained in surface crushing and screening plants. This will be evident in the table below where there is an increase of 36 per cent. in the number of samples from this source where the count exceeds 1,000+ p.p.c.c.

The table below gives the results of the count of dust samples taken in the year with figures for 1970 shown in brackets for comparative purposes.

Dust Samples from	Samples Giving Over 1,000+ p.p.c.c.	Total Number of Samples	Average Count
Surface Plants	57 (42)	433 (279)	406 (430)
Assay Office	1 (1)	16 (18)	273 (290)
Stoping	6 (6)	379 (552)	230 (239)
Levels	7 (11)	133 (221)	232 (263)
Development	1 (—)	112 (177)	209 (223)
	72 (60)	1,073 (1,247)	306 (284)

In most of the large crushing plants, particularly those used at iron ore mines, pressurised control cabins are provided for the operators and they work in relatively dust free atmosphere for most of the working shift.

Eleven fuming accidents were reported and investigated. These were minor accidents only. There were no fatal accidents.

There were seventy-six diesel engine equipped units in use underground. Thirty-four of these were operated at Western Mining Corporation Ltd. (Kambalda Nickel Operations). Thirteen units were in use at Mt. Charlotte Mine of Gold Mines of Kalgoorlie (Aust.) Ltd., Anaconda (Aust.) Inc. had six units, Selcast Exploration Ltd. had eight, Metals Exploration N.L. had five and Poseidon Ltd. had ten units. The units vary from Drilling Jumbos through Load Haul Dump units, Graders, front end loaders, to Truck and service vehicles of the Land-rover type. Regular sampling and analysing of the undiluted exhaust gas from the diesel engines is carried out in addition to a close check being kept on the mine atmosphere wherever diesel engine units operate. On application being made for permission to take and use a diesel engine underground the exhaust gases are sampled and analysed and included in the recommendations submitted.

There were no occurrences of methane gas. A gas emission with a trace of Hydrogen Sulphide was reported at the Durkin mine of Western Mining Corporation Ltd. (K.N.O.) and an emission of the same gas was reported from the Carr Boyd mine of Great Boulder Mines Ltd.

In conjunction with the Department of Public Health urine samples were obtained from men employed in gold assay laboratories.

#### GROUND VIBRATIONS

Most of the vibration measurements recorded with the Sprengnether Seismograph were due to blasting with explosive.

Only one series of recordings was necessary because of reported vibrations from a vibrating roller and this was during the construction of the Architectural School at the W.A. Institute of Technology.

There were three recordings made of blasting in hard rock quarries, one at a limestone quarry and others in bauxite mining pits. The recording made at the limestone quarry was to determine a distance from which a standard weight of explosive could be detonated without causing damage to the adjacent natural gas pipeline.

Further records of vibration from blasting in Geraldton Harbour were obtained for the Harbours and Rivers Branch of the Public Works Department. These blasts were from explosives confined in drill



holes. The vibrations showed a considerable reduction on those obtained with plaster charges placed on the sea bed and unconfined except for the overlying water. During the second period of these tests another Seismograph was borrowed and comparative readings obtained in various sections of the Town of Geraldton whilst the vibrations continued to be monitored from the closest point on the land to the blasting.

#### GENERAL

An increase in the number of Mining Engineers employed by the Department to eight has resulted in increased inspections of operations.

In the North-West area, based on Port Hedland, operating mines include the major iron ore projects, notable solar salt fields, manganese and tin with a small quantity of gold from small producers in the Marble Bar area. Minor operations for other minerals were in progress whilst substantial tonnages of aggregate for major construction projects are quarried or obtained from river gravels. There are a large number of persons employed by contractors on construction work in the industry. Frequent inspections of all major projects were made and other operations as possible.

Gold and nickel are the principal minerals mined in the Eastern Goldfields area based on Kalgoorlie. Other mining operations are for salt, gypsum, iron ore and feldspar. Regular and frequent inspections were made of all operations and in particular those new developments of nickel ore bodies in the Spargos-Widgiemooltha area, Windarra, and an area around Agnew. Shaft sinking was the major item of this development although some lateral development was undertaken. Declines for access to nickel ore bodies is a new feature of recent developments and has been brought about by the introduction of trackless diesel engine powered equipment.

Mineral sands, tin, iron ore, bauxite, gold mining and rock quarrying are the principal operations in the area based on Perth. The area extends from the Peak Hill Goldfield and south on the western side of the Rabbit proof fence. Inspections have been made of all these operations plus the mining of building stones, clays, cupreous ore, glass sand, gypsum, limestone and talc, etc., with treatment plants where bauxite is converted to alumina, nickel concentrates are refined to briquettes, and iron ore reduced to pig iron.

Four Special Inspectors of Mines (Machinery) have been attached to this Branch to carry out the Machinery inspections and the necessary examination and certification of machinery used in mines. One Inspector is based at Port Hedland, one in Kalgoorlie and two in Perth.

#### PETROLEUM EXPLORATION AND PRODUCTION

*A. J. Sharp—Petroleum Engineer*

#### BARROW ISLAND OILFIELD DEVELOPMENT

(Operators—West Australian Petroleum Pty. Ltd.)

No drilling was carried out on Barrow Island during 1971. The average rate of crude oil production throughout the year was approximately 44,000 bbls/day, compared with an average production rate in 1970 of 46,000 bbls/day.

A steady decline in production rate is expected to occur over the remaining life of the field. Water

injection into the Windalia reservoir was continued at a rate of averaging 125,000 bbls water per day.

	No. of Wells, December, 1970	No. of Wells, December, 1971
Producing oil wells	329	328
Part-time producing oil wells	2	0
Non-producing wells	9	12
Water injection wells	153	153
Water source wells	9	9
Total number of wells	502	502

#### DONGARA/YARDARINO/MONDARRA/GINGIN GAS FIELD DEVELOPMENT

(Operators—West Australian Petroleum Pty. Ltd.)

The Dongara gas field commenced production in late October, 1971. Natural gas from the Dongara wells is transmitted through a field pipeline gathering system to a centrally positioned gas treatment plant. At the treatment plant the natural gas is processed to remove water and condensate produced in association with the natural gas.

The dry gas is then flowed through metering equipment which records the total field gas production. The gas then enters the Dongara to Pinjarra natural gas pipeline which transmits the gas to sales points in the Perth area. The condensate removed from the natural gas is stored in two 1,000 barrel tanks at the treatment plant and then transported by road tanker to sales points.

Similar production facilities are being installed at the Mondarra and Gingin gas fields and production from these fields is expected to commence in early 1972.

#### DONGARA TO PINJARRA NATURAL GAS PIPELINE

(Operators—West Australian Natural Gas Pty. Ltd.)

The construction of the Dongara to Pinjarra natural gas pipeline commenced at Pinjarra in January, 1971.

The main pipeline is approximately 260 miles long and 14 in. in diameter with laterals to the Midland Brick plant, the S.E.C. Perth gas works, the Swan Cement plant, the S.E.C. power station and the Western Aluminium plant at Kwinana. Further laterals to the Fremantle Gas works and Western Mining Nickel Refinery are expected to be commenced in 1972.

During the construction phase natural gas was discovered at the Walyering No. 1 well about 100 miles north of Perth and the pipeline route was realigned to pass close to this well.

The pipeline commenced operation in October, 1971 and in December, 1971 was transmitting gas from the Dongara field to Perth and Kwinana at an average rate of 26 million cu. ft. per day. The transmission rate is expected to increase to 80 million cu. ft. per day in 1972.

#### LAND EXPLORATION DRILLING

Land exploration and appraisal drilling operations carried out in 1971 are summarised in the attached table. The only significant quantity of petroleum discovered in 1971 from land exploration operations was by West Australian Petroleum Pty. Ltd. at the Walyering No. 1 well. The well was tested after

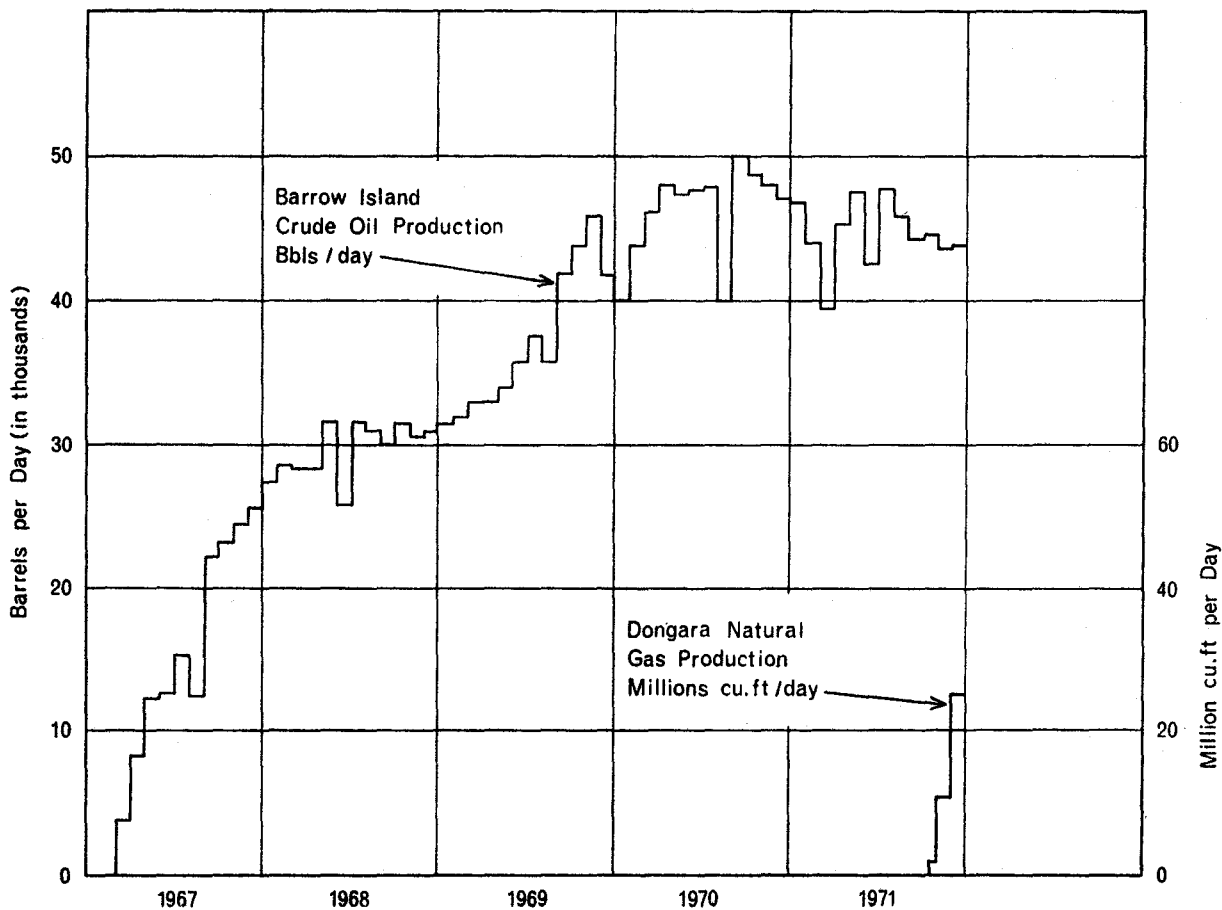
drilling at a rate of 10.6 million cu. ft. gas per day on a  $\frac{1}{2}$  in. surface choke. An extended production test of the Walyering No. 1 well to evaluate the reservoir is to be carried in early 1972, after equipment has been installed at the well site to flow the test production into the Dongara/Pinjarra pipeline.

### OFFSHORE EXPLORATION DRILLING

Offshore exploration drilling operations carried out in 1971 are summarized in the attached table. The first major offshore gas discovery was made in June, 1971 by the B.O.C./Woodside/Shell/Mid-Eastern/B.P./California Asiatic group of companies at the Scott Reef No. 1 well. The well was tested at rates up to 18 million cu. ft. of gas per day on a 1 in. surface choke with gas condensate rates of approxi-

mately 14 bbls condensate per million cu. ft. of gas. Scott Reef is located some 270 miles north of Broome and is about 180 miles from the mainland. Shortly after the discovery of gas at Scott Reef the first of a series of major offshore gas discoveries at distances of between 80 and 90 miles from Dampier was made by the same group of companies at the North Rankin No. 1 well in July, 1971. The well penetrated gas reservoirs with a net thickness of hydrocarbon pay zone of approximately 1,000 feet. Several zones in the well were tested at rates up to 13 million cu. ft. of gas per day with a gas condensate ratio of about 25 bbls condensate per million cu. ft. gas. The North Rankin discovery was followed by the Rankin No. 1 gas discovery 28 miles south-west of North Rankin in October, 1971 and the Goodwyn No. 1 gas discovery, 16 miles south-west of North Rankin in December, 1971. A technical and economic liquid natural gas feasibility study is being carried out by the permittee.

AVERAGE DAILY CRUDE OIL AND NATURAL GAS PRODUCTION BY MONTHS



OFFSHORE PETROLEUM EXPLORATION DRILLING IN WESTERN AUSTRALIA, 1971

Operator	Contractor	Rig	January	February	March	April	May	June	July	August	September	October	November	December
B.O.C. ....	Global Marine	Glomar Tasman	Lynher No. 1 8,940' P. & A.				Scott Reef No. 1 15,520' Gas discovery				Rankin No. 1 13,488' Gas discovery		Angel No. 1 Gas discovery	
B.O.C. ....	Odeco	Ocean Digger					North Rankin No. 1 11,593' Gas discovery			Bedout No. 1 10,082' P. & A.	De Gray No. 1 6,850' P. & A.		Goodwyn No. 1 Gas discovery	
W.A.P.E.T. ....	Offshore Drilling	Jubilee	Warnbro 12,009' P. & A.											
W.A.P.E.T. ....	Odeco	Ocean Digger	Char- lotte 7,990' P. & A.	Gage Roads 9,750' P. & A.		Sugar Loaf No. 1 12,000' P. & A.								
A.R.C.O. ....	Zapata	Navigator	Gull No. 1 11,225' P. & A.				Tern No No. 1 14,278' P. & A.			Sandpiper No. 1 6,206' P. & A.				
A.R.C.O. ....	Sedco	135 G									Flamingo No. 1 12,139' P. & A.			

LAND PETROLEUM EXPLORATION/APPRaisal DRILLING IN WESTERN AUSTRALIA, 1971

Operator	Contractor	Rig	January	February	March	April	May	June	July	August	September	October	November	December	
W.A.P.E.T. ....	O.D.E.	Ideco Super 7-11			Walyering No. 1 12,000' Gas discovery		Gin Gin No. 1 Work- over				Walyering No. 2 13,501' P. & A.				
W.A.P.E.T. ....	O.D.E.	H-525		West White Point No. 1 7,378' P. & A.	Ningaloo 4,030' P. & A.	Sandy Point 551' P. & A.								West White Point No. 2 7,728' P. & A.	
W.A.P.E.T. ....	O.D.E.	Ideco Junior Super 7-11							Tappers Inlet 9,571' P. & A.			Lake Betty No. 1 10,821' P. & A.			
W.A.P.E.T. ....	Intair-Dril	Franks Rocket								Cross Lands No. 1 2,998' P. & A.	Cross Lands No. 2 3,000' P. & A.	Cross Lands No. 3 3,003' P. & A.	Munda No. 1 3,500' P. & A.		
Hematite	Intair-Dril	Franks Rocket												Cane River No. 1 2,273' P. & A.	No. 2 1,355' P. & A.

## COAL MINING

*R. S. Ferguson—Mining Engineer—  
Senior Inspector of Coal Mines*

The aggregate output of coal produced on the Collie Coalfield during 1971 amounted to 1,171,624 tons, a decrease of 26,109 tons compared with the record output of 1,197,733 tons achieved in 1970. This represents a decrease of 2.2 per cent. on the 1970 output.

The three collieries contributing to the output were Western No. 2 underground mine, Western No. 5 Open Cut Mine and Muja Open Cut.

The total value of the coal produced during 1971 was \$5,734,353, a decrease of \$92,938, compared with the 1970 value of \$5,827,291.

The Open Cut component of the total output increased by 4.16 per cent. to 65.14 per cent.

### *Western Collieries Ltd. Western No. 2 Mine*

This Colliery's output of 408,380 tons of coal was a decrease of 58,918 tons compared with the 1970 output of 467,298 tons. This curtailment of production in relation to the market demand for coal is unfortunate as the colliery has the potential to be a major producer.

Systematic development of the mine to provide for water control and drainage with layouts ultimately suitable for the maximum economic extraction of coal has necessitated development heading drivages being undertaken on a wide scale.

The maximum distance along a direct line between the north-west and south-east extremities of the workings, being the No. 1 West and No. 6 East Development Heading faces is 3 miles 6 chains.

The depths of cover over current workings range from 80 feet near the top of No. 1 West "B" Panel to 465 feet at the bottom of No. 1 West "C" Panel. The maximum depth of cover is approximately 511 feet.

No. 1 West, No. 4 West and No. 6 West Districts were the main areas of development and working during the year whilst development continued to a lesser extent in the No. 2 West and No. 6 East Districts and in the Cullen Headings.

An additional main return airway was established at the west side of the mine where the drift connecting from the top of No. 1 West "B" Panel belt heading was driven to the surface at the position where an exhausting axial flow fan was installed.

The main ventilation of the mine was good in the single circuit on the east side of the mine and in the composite circuit comprising two splits on the west side. Greatly improved face ventilation was achieved in many areas following a wider use of brattice in place of auxiliary fans.

### *Western Collieries Ltd. Western No. 5 Open Cut*

The output of this mine was 151,490 tons, an increase of 47,246 tons over the previous year when, however, the mine did not commence production until March, 1970.

The entire output for this year was won from the Neath Seam where the excavation which averages approximately 3½ chains in width was extended to a length of approximately 46 chains.

At the end of the year, the main reserves of exposed coal existed at the north end of the excavation where a Cat 950 front-end-loader operating in conjunction with a conveyor installation was achieving good progress on overburden removal. The conveyor system provides for the ultimate discharge of overburden over the main surface dump from structural extensions slewed to the required position around the dump perimeter.

Most of the coal won during the year was uncovered by mobile scraper units which achieve some very good results despite difficulties experienced during wet weather conditions. Coal loading was effected by a Cat 988 front-end-loader.

Good progress was being made towards exposure of an additional area of Neath Seam coal where the Stage 2 excavation project involving an advancement of the high wall, and back-filling of overburden into an adjacent mined out area was continuing as the main development project at the mine.

Consideration was being given to the implications of diverting a portion of the South Branch of the Collie River ahead of the excavations.

Good standards of lighting were maintained in and around the excavations to provide for safe working conditions during the hours of darkness on afternoon shift.

On the surface, a new workshop was constructed, the main coal haulage road to Muja Generating Station was bitumenised, auxiliary roads were established and the electric power distribution system was extended.

### *The Griffin Coal Mining Company Limited.*

#### *Muja Open Cut*

This colliery again produced the largest individual mine output on the field. The output of 611,754 tons was however a reduction of 14,438 tons compared with the previous year's output of 626,192 tons.

The total quantity of overburden removed to expose coal was 2,906,063 cubic yards or 28,827 cubic yards less than the figure of 2,934,890 cubic yards removed to expose coal in 1970. The average rates of overburden removal to coal mined was 4.75 to 1, practically the same as for last year. An additional 80,371 cubic yards of overburden was removed during pit preparation procedures which did not include coal exposure.

Very good progress was made on removal of overburden from the Block No. 5 Area which extends across the short axis of the Muja Coal formation from the South wall to the high wall of the East Extension Area on the north side. A considerable area of the Eos Seam was exposed and some coal was won from the Block while a small area of the Galatea Seam was exposed at the north-end.

The 200W Bucyrus Erie Dragline and four 71RB face shovels were operating at various levels and at widespread locations on systematic excavation over the large area of this block.

Only a limited quantity of Block No. 3 coal remained at the end of the year. In this area, close to the South-wall, the gradient was steep and separation of the Hebe Seam into three different bands interspersed with shales made mining relatively difficult.

Exposure of the Hebe Seam was completed on Block No. 4 and mining of this seam was completed on Block No. 2.

Definite plans were made for backfilling overburden to commence in the south-west of the excavations, generally in the mined out Block No. 2 Area. Proposals for this work were drawn up following a systematic site investigation of the area.

Construction of an access road comprising successively consolidated layers of backfill debris flanking the South wall was in progress and in this project, as with the general backfilling proposals, the design provides for special techniques of site preparation and drainage to ensure maximum stability of the consolidated debris.

Overburden dumps and excavation berms were stable and safe in all areas.

Lighting arrangements and roads and surfaces were efficiently maintained to a high standard.

#### General

There were no fatal accidents during the year and the accident record in the coal mining industry continued to be good. There were 220 reported accidents of which 187 were minor and 33 were classified as serious, mainly for statistical purposes where an employee was absent from work for 15 days or more.

Officers of the State Department of Public Health were in attendance on seven separate days during June and July 1971 to test the hearing of mine employees. 268 people were tested and subsequently audiograms were made available to the local Medical Practice. Recommendations for a hearing conservation programme in the coal industry were made by the Public Health Department.

A joint Western Collieries and Peabody Pty. Ltd. exploratory drilling programme was in progress from November 1971 and it is anticipated that 100,000 feet of drilling will be undertaken before completion of the project.

Westcoll Research Laboratories, a subsidiary of Western Collieries Ltd., was established in August 1970 to provide routine analytical services to the Company's two operating mines and to exploration: to conduct research on problems germane to mining, processing and marketing and to extend this, where appropriate, to pilot processing. At present, the laboratory at Collie is equipped for standardised coal analysis, mineral analysis, petrography and bore core X-Ray radiography. Also, a pilot plant using the fluidizing principle is in operation. It has a capacity of 15,000 tons per annum of dried coal or 10,000 tons of char and it is being used to establish markets for these upgraded products. Typical analyses are:—

	<i>Dried Coal</i>	<i>Char</i>
Moisture %	8	1
Ash %	5	7
Volatiles %	30	9
Fixed Carbon	57	83
C.V. BTU's/lb	12,000	—

The West Australian Char Company Ltd., a combination of the Griffin Coal Mining Company and two major Japanese firms, Marubeni-Iida Co. Ltd., and Kokan Mining Co. Ltd., established a char plant adjacent to the Muja Open Cut mine and Muja Generating Station. The proposed initial output is 10,000 tons of char a year involving the use of 18,000 tons of coal.

There was a slight reduction in the total number of personnel employed in the coal mining industry compared with the previous year. The number of employees at the end of the year was 606 or twenty less than the 626 employees in December, 1970.

## DRILLING OPERATIONS

*D. A. MacPherson—Drilling Engineer*

During 1971 the Drilling Section was responsible for the drilling of 26,204 feet in 82 bores and the testing by pumping of 46 bores. The drilling of 24,162 feet in 68 bores and the testing of 30 bores was carried out by Departmental employees and equipment. The remaining 2,042 feet drilled in 14 bores and the testing of 16 bores was carried out by contract.

A brief resume of each operation follows and a table of the work carried out is given at the end of this report.

Comments on Staff and Plant matters are also given.

### PORT HEDLAND—STAGE FOUR

This work was a continuation of the 1970 investigation into the possibility of obtaining water for Port Hedland from groundwater sources located in the De Grey River alluvium. The work was carried out for and financed by the Department of Public Works.

The drilling work consisted of the construction of a pumping bore at each of seven sites and at each of two of these sites, the construction of two observation bores. The pumping bores were subsequently tested to determine quality and quantity of available water. Four of the bores were constructed by cable tool methods and the remaining seven were constructed by rotary methods.

The bores were located partly on the basis of seismic survey work carried out in the area by the Geological Survey of Western Australia.

The work was made expensive because of poor access. To construct two of the bores it was necessary to build a three quarter mile long crossing over the sandy bed of the Shaw River, using old railway sleepers.

On completion of the work, all plant and material were moved out of the area.

### GNANGARA SANDBEDS—STAGES THREE AND FOUR

This work was a continuation of the 1970 investigation of Perth's groundwater resources, conducted on behalf of the Metropolitan Water Supply, Sewerage and Drainage Board and financed by that Department.

Stage three of the work consisted of the construction of one fully penetrating screened bore and one fully penetrating gravel packed bore at each of two selected sites in the job area and their subsequent testing to provide a basis for selection of the most suitable bore construction method in the area. This stage was in progress at the end of 1970 and was completed in 1971. The work showed that the fully penetrating screened bore was the most suitable method of construction.

Stage four consisted of the construction and testing of a fully penetrating screened bore at each of thirteen sites in the job area and the removal of the bore casing and screens from a number of bores in

the area. This stage was almost completed at the end of 1971—the only remaining work was the removal of casing and screens from a few bores.

Early in the year, the very sandy access tracks in the job area were limestoned and the improvement in access reduced very considerably the difficulties previously encountered on this work.

#### MIRRABOOKA

This work formed part of an investigation of Perth's groundwater resources conducted by the Metropolitan Water Supply, Sewerage and Drainage Board and was financed by that Department. It consisted of drilling one bore by cable tool method and testing the bore to determine water quality and quantity. The bore had been drilled during 1970 and during 1971 it was tested and the job completed.

#### GWELUP—STAGES ONE AND TWO

This operation forms part of an investigation of Perth's groundwater resources conducted by the Metropolitan Water Supply, Sewerage and Drainage Board and was financed by that Department.

Stage one entailed drilling a bore at each of six sites to determine strata and water quality, and the subsequent development of these bores to serve as water level observation points.

At the commencement of 1971, two bores remained to be drilled. This stage was completed by a contractor using rotary methods.

Stage two consisted of constructing six pumping bores at each of the six sites used in stage one, and the subsequent testing of the pumping bores to determine water quality and quantity. This work was carried out by a contractor, using rotary methods.

Stage two also called for the drilling of a 1,200 feet bore to determine strata, and the formation testing of this bore to provide information on water levels and water quality. This bore was drilled and the necessary testing carried out by Departmental personnel and equipment using rotary methods.

#### WYNDHAM

This operation was a continuation of the 1970 investigation of the strata underlying Wyndham Harbour, required for the design of a barge loading facility. The work was carried out on behalf of and financed by the State Shipping Service.

This work involved obtaining strata samples by thin wall sample tube and carrying out penetration tests in the upper soft strata and diamond core drilling in the underlying hard strata. Some of the work was carried out with the plant mounted on a barge floating in water. The operation was completed early in 1971 and all equipment removed from the area.

#### MUCHEA

This operation forms part of the State-wide water investigation programme conducted by the Geological Survey of Western Australia and was financed by the Department of Mines.

The work was a continuation of the 1970 investigation and consisted of drilling one pumping bore and one observation bore at each of two selected bore sites by cable tool methods and testing the pumping bore at each site. An additional bore was drilled at each site for camp and drilling water supply.

The work was completed and all equipment removed from the area.

#### WATHEROO LINE

This operation formed part of the State wide water investigation programme conducted by the Geological Survey of Western Australia and was financed by the Department of Mines.

The Watheroo Line consists of twelve bore sites at selected points on a line running west from Watheroo to the coast. At each site, information is required on strata and water beds to a projected depth of 2,500 feet.

Four sites had been completed by the end of 1968 and work was resumed early in 1971, using rotary drilling methods.

The work at each site consists of drilling an initial bore to the projected depth, electronic logging of this bore, sidewall coring at depths selected by the logging, casing and screening the bore to a water bed selected by the logging, developing and pumping the bore to give reliable water level and water quality information and an indication of the water bed yield potential; then drilling, casing, screening and testing further bores to other water beds selected by the logging.

This operation saw the first use made of sidewall coring by the Department and this method of coring carried out by contract, has proved very suitable for the work, in comparison to the conventional coring methods. The work, except for the sidewall coring, was carried out by Departmental personnel and equipment.

At the end of the year, three sites remained to be completed on the line and work will be continued during 1972.

#### WILUNA

This operation forms part of the State wide investigation programme conducted by the Geological Survey of Western Australia and was financed by the Department of Mines.

The work was a continuation of the 1969 investigation. It involved reaming out selected bores from the 1969 investigation to allow high rate testing of the bores and the drilling of pumping bores and observation bores at selected new sites and the testing of the pumping bore at each site.

The work was done by Departmental personnel and equipment using cable tool methods.

The operation was completed during 1971 and all plant and equipment removed from the area.

#### PORT HEDLAND—2nd LAND BACKED BERTH

This work was carried out to investigate foundation conditions at Port Hedland Harbour for preparation of designs for a new berth in the harbour. The work was carried out on behalf of and financed by the Public Works Department.

The operation involved obtaining samples by thin wall sample tube and carrying out penetration tests in soft strata and diamond core drilling underlying harder strata. Some of the work was carried out with the plant on land and the remainder with the plant on a barge floating in water.

#### COOYA BOOYA—ROEBOURNE

This work is an investigation into the possibility of obtaining water for Roebourne and associated towns from ground-water sources additional to those already being utilised. It was carried out for and financed by the Public Works Department.

Initially this job consisted of the construction of one bore by cable tool method and its testing to determine quality and quantity of available water—the testing to be carried out at suitable intervals during the construction of the bore.

The bore was commenced late in the year and was still in progress at the end of 1971. It will be continued in 1972.

#### BUNBURY HARBOUR

This drilling is being carried out to provide information on foundation conditions in Bunbury Harbour required for preparation of designs for a land backed berth. The work is being carried out on behalf of and financed by the Public Works Department.

The work involves obtaining samples by thin wall sample tube and diamond core drilling underlying harder strata.

Operations commenced late in the year with the plant based on land and this work was still in progress at the end of 1971. It will be continued in 1972 with the plant mounted on a barge floating in water.

#### STAFF

During 1971 the only staff change was the resignation of Mr. I. Cochrane, general assistant in the Carlisle Drill Store. His place was taken by Mr. R. Snaire.

#### PLANT

During 1971 a heavy duty four wheel drive tractor was received and placed in service.

A truck mounted, medium capacity rotary drilling plant and a trailer mounted, power swivel unit were also received and at the end of the year, were being prepared for service.

At the end of the year, delivery was imminent of the new gamma ray well logging unit for use by the Geological Survey of Western Australia and a side wall coring unit for use by the Drilling Section. Delivery of the two items is expected during January, 1972.

A Mindrill A2000 diamond drilling plant, written-off during 1970, was offered for sale during 1971. Tenders were received but at the end of the year, the sale had not been completed.

Various items of plant which had reached the end of their economic life were replaced.

#### BOARD OF EXAMINERS

##### FOR MINE MANAGERS' AND UNDERGROUND SUPERVISORS' CERTIFICATES

*W. J. Cahill—Secretary*

Herewith I submit the Annual Report on the activities of the Board of Examiners for the year, 1971.

#### *Mining Law Examinations*

As in 1970, two examinations in Mining Law for Mine Managers' Certificates of Competency were held, one on April 19th, 1971 and one on October 18th, 1971.

Details were as follows:—

Examinations held on April 19th, 1971:—

Entries	....	....	....	....	....	11
Admitted	....	....	....	....	....	11
Pass	....	....	....	....	....	7

The names of the successful Candidates were:—

#### *First Class*

L. Watermyer	H. D. Swain
A. J. Palmer	R. M. Smith
N. R. Hooker	B. L. Grieves
T. J. Potts	

Examination held on October 18th, 1971:—

Entries	....	....	....	....	....	8
Admitted	....	....	....	....	....	7
Pass	....	....	....	....	....	4

The names of the successful candidates were:—

#### *First Class*

P. R. Coates	J. R. McDougall
A. C. Cruickshank	G. V. Parker

#### *Underground Supervisors Examination*

The written examination was held on November 16th, 1971 and applications were received from the following centres:—

Kalgoorlie	....	....	....	....	....	39
Norseman	....	....	....	....	....	2
						41
						—

The results were as follows:—

Passed	....	....	....	....	....	22
Fail	....	....	....	....	....	17
Did not sit	....	....	....	....	....	2
						41
						—

Certificates of Competency have been issued to the successful candidates as follows:—

#### *Kalgoorlie*

J. B. Aitken	J. H. Marshall
O. Bertocchi	L. Molin
W. Brodoswki	S. Procak
E. R. Burnham	J. Rickard
C. E. Butcher	H. F. Rourke
R. C. Carstens	P. G. Rowe
F. Crook	D. Smiljanic
W. Darlington	C. T. Snowden
W. T. Duckett	E. Tagliaferri
J. H. Gibson	A. G. P. Walker

#### *Norseman*

P. Blyth	} Both restricted to Norseman Mines only.
B. C. Lovely	

#### *Mine Manager's Certificates*

The following were successful applicants for Mine Manager's Certificates of Competency.

#### *First Class*

M. D. O'Brien
C. J. B. Lewis
P. A. R. Odd
T. S. Potts
H. D. Swain
B. L. Grieve

#### *Second Class*

R. J. McQuiggin
J. Schrott
P. King

#### *General*

Four meetings were held during the year on March 23rd, May 4th, July 23rd (Special, held in Perth) and October 5th.

During the year the Board of Examiners visited Kalgoorlie and Norseman to examine candidates orally for the Underground Supervisors Examination.

# DIVISION III

## Report of the Superintendent of State Batteries—1971

### UNDER SECRETARY FOR MINES

For the information of the Hon. Minister for Mines I submit my report on the operations of the State Batteries for the year ending 31st December, 1971.

#### *Crushing Gold Ores*

One 20 head, four 10 head, and nine 5 head mills crushed 27,985½ tons of ore made up of 204 separate parcels, an average of 137·19 tons per parcel. The bullion produced amounted to 9,914 ozs. which is estimated to contain 8,402 ozs. of fine gold equal to 6 dwts. of gold per ton of ore.

The average value of the ore after amalgamation, but before cyanidation, was 1 dwt. 15 grs. Thus the average head value of the ore was 7 dwts. 15 gr. which is 22 grs. less than the previous year's average.

A total of 202½ tons of tantalite ore and 172 tons of tungsten ore was also crushed at the plants that crush mainly gold ores. The average cost for crushing the 28,360½ tons was \$14·48 per ton, compared with 1970 when 24,459 tons were crushed at a cost of \$15·34 per ton.

#### *Cyaniding*

Five plants treated 12,241 tons of tailings from amalgamation for a production of 1,394 fine ozs. of gold. The average content was 3 dwts. 5 grs. before cyanidation, while the residue after treatment averaged 22 grs. The theoretical extraction was, therefore, 71·03 per cent. The actual extraction was 70·83 per cent.

The cost of cyaniding was \$8·56 per ton, which was less than the previous year, when 7,953 tons were treated at a cost of \$10·13 per ton.

Silver recovered by the cyanidation of gold tailings amounted to 99·9 fine ozs. valued at \$105·22.

### TREATMENT OF ORES OTHER THAN GOLD

#### *Lead Ores*

During the year the Northampton State Battery crushed 1,160½ tons of lead ore with an estimated average content of 6·99 per cent. lead and 4·44 per cent. zinc. There were 9 separate parcels, giving an average of 128·9 tons of ore per parcel.

A total of 136·15 tons of concentrates was produced. The concentrates averaged 45·19 per cent. lead and 15·78 per cent zinc giving an estimated content of 61·52 tons of lead and 21·48 tons of zinc in concentrates.

1,024·1 tons of tailings were discarded. These had an average content of 1·91 per cent. lead and 2·94 per cent. zinc, giving a total of 19·53 tons of lead and 30·08 tons of zinc discarded in tailings.

The recovery in the concentrates was 75·9 per cent. of the lead and 41·7 per cent. of the zinc in the ore delivered to the Plant.

The cost of operating the Northampton State Battery, including administration, was \$35,866·29, being \$30·91 per ton of ore crushed. Revenue received was \$2,601·26 being \$2·24 per ton. The corresponding figures for 1970 when 3,744½ tons of ore were crushed, were operating cost \$44,512·23 being \$11·89 per ton, and revenue \$7,547·00 being \$2·02 per ton.

#### *Tin Ore*

No tin ore was crushed for the year but the Marble Bar magnetic separator plant treated 26·95 tons of low grade alluvial concentrates for a recovery of 11,517 lb. of high grade tin concentrates valued at \$11,010.

#### *Tantalite Columbite Ores*

The Boogardie State Battery crushed 202·75 tons of tantalite ore from which 556 lb. of concentrates valued at \$934 were recovered.

The Marble Bar magnetic separator plant recovered 1243 lb. of high grade tantalite concentrates valued at \$6,800 and also 11,701 lb. of low grade tantalite concentrates valued at \$2,990.

#### *Tungsten Ore*

The Menzies State Battery treated 172 tons of tungsten ore from which 351 lb. of concentrates valued at \$470 were recovered.

#### *Value of Production*

The estimated value of production from the State Batteries since their inception, excluding the value of gold tax paid to the Commonwealth is:—

	GOLD		Grand Total
	1971		
Par Production—			
Crushing	\$ 71,382		\$ 18,281,060
Cyanidation	11,842		4,503,275
Gold Premium—			
Crushing	191,192		12,769,699
Cyanidation	31,717		3,515,377
Open Market Premium—			
Crushing	31,817		162,242
Cyanidation	5,278		48,461
Total Gold Production	\$343,228		\$39,280,114



OTHER ORES REALISED

	1971 \$	Grand Total \$
Silver .....	105	4,063
Tin—		
Ores and Concentrates .....	11,010	469,690
Residues .....		1,144
Tungsten Concentrates.....	470	39,366
Agricultural Copper Ore .....		11,932
Lead Concentrates .....	20,578	1,389,134
Tantalite-Columbite Concentrates .....	10,724	72,721
Total Other Ores .....	\$42,887	\$1,988,050
Grand Total .....	\$386,115	\$41,268,164

FINANCIAL

	Tons	Expenditure \$	Receipts \$	Loss \$
Crushing—Gold Mills .....	28,360.5	410,524	26,615	383,909
Magnetic Separator Plant—				
Marble Bar .....	26.95	2,775	1,118	1,657
Crushing Lead Mill—Northampton .....	1,160.25	35,866	2,601	33,265
Cyaniding .....	12,241	104,795	24,392	80,403
		\$553,960	\$54,726	\$499,234

The loss of \$499,234 is an increase of \$50,168 on the previous year. It does not include depreciation and interest on capital.

Capital expenditure all from Consolidated Revenue Fund, was incurred as follows:—

	\$
Coolgardie .... Repair Stamp Mill and Mill Battery .....	9,551
Kalgoorlie .... Repair supports for Stamp Mills and Fine Ore Blus .....	1,549
Leonora .... Erection of Cyanide Plant .....	6,412
Marble Bar .... Changeover to A.C. Power .....	989
	\$18,501

Cartage Subsidies

	Tons	Cost
Ore carted to State Plants	15,241½	\$22,321

Comparative Figures for the last three years are:—

Year	State Plants				Private Plants		
	Tons Crushed	Tons Subsidised	% Subsidised	Cost	Tons Subsidised	Cost	Total Cost
1969....	33,568½	14,912½	44.42	\$ 20,629	Nil	Nil	\$ 20,629
1970....	28,264½	12,450½	44.05	22,815	Nil	Nil	22,815
1971....	29,547½	15,241½	51.58	22,321	Nil	Nil	22,321

Administrative

Expenditure amounted to \$87,668.47 equivalent to \$2.10 per ton of ore crushed and cyanided, compared with an expenditure of \$74,546.15, \$2.30 per ton, for 1970.

	1970 \$	1971 \$
Salaries .....	46,193.40	51,088.76
Pay Roll Tax .....	8,543.97	11,015.05
Workers Compensation .....	12,371.70	18,523.32
Travelling and Inspection .....	4,092.63	2,548.03
Sundries .....	3,344.45	4,493.31
	\$74,546.15	\$87,668.46

Staff

There were no staff changes during the year.

General

The gold ore crushed was 5,175 tons more than in 1970. The increase was mainly in the later part of the year when there was much less interest in nickel prospecting, and higher prices were received for gold. It is expected that there will be a further increase in gold ore crushed at the State Batteries in 1972.

The new cyanide plant at Leonora started treatment near the end of 1970. Its continuous operation in 1971 was mainly responsible for the big increase in tailings treated.

The Northampton State Battery crushed only 1,160½ tons of ore for the year. Half of this ore came from the Ethel Maud Mine near Galena. This ore is unusual for the district as it contains more zinc than lead. The Northampton State Battery is designed to recover the high density lead minerals and is less efficient in recovering the much lower density zinc minerals. The Ethel Maud ore also contains a considerable amount of garnet which has almost the same density as the main zinc mineral, sphalerite. As it was necessary to remove most of the garnet to make a saleable lead-zinc concentrate, much of the zinc mineral was also lost. A flotation plant would be required to give a high recovery of zinc from this ore.

As expected the crushing of tantalite ore at Boogardie ceased early in the year, due to the low grade of the ore being mined.

Some old tailings containing scheelite were treated at the Menzies Battery. A good grade tungsten concentrate was obtained by using a curvilinear table, but the amount recovered was insufficient to make the project economical.

There is at present very little alluvial tin being recovered by small producers in the Marble Bar area. The Marble Bar State Battery magnetic separator treating only 26.95 tons for the year.

K. M. PATERSON,  
Superintendent State Batteries.

Schedule No. 1

NUMBER OF PARCELS TREATED, TONS CRUSHED, GOLD YIELD BY AMALGAMATION AND HEAD VALUE FOR THE YEAR ENDED 31st DECEMBER, 1971

Number of Parcels Treated	Battery	Tons Crushed	Yield by Amalgamation				Amalgamation Tailings Content	Contents of Ore-Fine Gold				
			Bullion		Fine Gold			Total		Per Ton		
			Ozs.	Dwts.	Ozs.	Dwts.		Ozs.	Dwts.	Ozs.	Dwts.	
7	Boogardie	109.25	53	18	45	14	15	13	61	7	11	5
16	Coolgardie	852.00	451	1	382	5	79	14	461	19	10	20
62	Kalgoorlie	12,891.00	5,769	11	4,889	14	680	15	5,570	9	8	15
4	Lake Darlot	188.00	57	9	48	14	15	12	64	6	6	20
14	Leonora	891.50	351	17	298	4	182	6	480	10	10	19
14	Marble Bar	660.00	269	12	228	8	137	6	365	14	11	2
31	Marvel Loch	3,505.50	1,833	10	1,553	18	520	3	2,074	1	12	.....
15	Meekeatharra	5,290.00	529	15	448	19	508	5	957	4	3	15
5	Menzies	89.50	39	15	33	14	7	1	40	15	8	5
6	Norseman	251.00	133	15	113	7	15	12	128	19	10	7
10	Ora Banda	2,286.00	235	16	199	17	52	11	252	8	2	5
2	Paynes Find	74.00	20	14	17	11	6	.....	23	11	6	9
2	Sandstone	87.00	18	6	15	10	11	10	27	.....	6	5
10	Yarri	801.00	149	4	126	9	42	9	168	18	4	5
204		27,985.75	9,914	3	8,402	4	2,274	17	10,677	1	7	15

Average Tons per Parcel ..... 137.19  
 Average Yield by Amalgamation per ton (Fine Gold) ..... 6 dwts. 0 grs.  
 Average Value of Tailings per ton (Fine Gold) ..... 1 dwt. 15 grs.

Schedule No. 2

DETAILS OF EXTRACTION TAILINGS TREATMENT 1971

Battery	Tons Treated	Head Value		Tail Value		Calculated Recovery		Actual Recovery	
		Per Ton	Total content	Per Ton	Total content	Ozs.	%	Ozs.	%
		Dwts. Grs.	Ozs.	Dwts. Grs.	Ozs.	Ozs.	%	Ozs.	%
Coolgardie	561	3 20	107.50	0 21	24.30	83.20	77.39	88.18	82.02
Kalgoorlie	3,600	2 09	424.75	0 14	107.75	317.00	74.63	311.21	73.27
Leonora	3,300	3 22	643.15	1 11	238.85	404.30	62.86	408.29	63.48
Marble Bar	348	9 14	166.75	1 16	29.20	137.55	82.40	135.10	81.02
Marvel Loch	3,772	2 17	510.30	0 18	141.75	368.55	72.22	364.59	71.45
Norseman	660	3 12	115.60	0 21	28.30	87.30	75.52	86.53	74.85
	12,241	3 05	1,968.05	0 22	570.15	1,397.90	71.03	1,393.90	70.83

Schedule No. 3

DIRECT PURCHASE OF TAILINGS FOR THE YEAR ENDED 31st DECEMBER, 1971

Battery	Tons of Tailings Purchased	Initial Payment to \$28 per Fine oz.
Boogardie	24.00	\$ 155.21
Coolgardie	163.75	1,126.36
Kalgoorlie	640.75	2,177.63
Leonora	1,494.00	5,168.94
Marble Bar	293.00	544.28
Marvel Loch	2,019.75	2,116.17
Norseman	26.00	29.72
Sandstone	62.00	275.86
	4,723.25	11,594.17

Schedule No. 4

STATEMENT OF RECEIPTS AND EXPENDITURE FOR THE YEAR ENDED 31st DECEMBER, 1971

Milling

Battery	Tons Crushed	Management and Supervision	Wages	Stores	Total Working Expenditure	Cost per Ton	Repairs and Renewals	Sundries	Gross Expenditure	Cost per Ton	Receipts	Receipts per Ton	Profit	Loss
Boogardie	312.00	8,892.02	6,325.30	1,850.73	17,068.05	54.71	1,779.04	4,658.73	23,505.82	75.34	512.64	1.64	.....	22,993.18
Coolgardie	852.00	7,216.09	13,010.47	2,716.58	22,943.14	26.93	7,995.57	3,385.32	34,324.03	40.29	1,047.33	1.22	.....	33,276.70
Cue	.....	.....	.....	.....	.....	.....	.....	47.80	47.80	.....	1,905.00	.....	1,857.20	.....
Kalgoorlie	12,891.00	14,575.02	31,652.90	13,626.54	59,854.46	4.64	12,695.52	33,952.92	106,502.90	8.26	10,385.81	.....	.....	96,117.09
Lake Darlot	183.00	2,227.27	1,166.76	270.37	3,664.40	19.49	150.46	128.11	3,942.97	20.97	94.45	.....	.....	3,848.52
Laverton	.....	.....	1,168.44	49.50	1,217.94	.....	1,193.84	372.11	2,783.89	.....	450.00	.....	.....	2,333.89
Leonora	891.50	1,315.26	8,291.63	4,573.29	14,180.18	15.91	2,282.68	6,303.67	22,766.53	25.54	972.51	.....	.....	21,794.02
Marble Bar	660.00	11,994.25	5,961.93	4,196.07	22,152.25	33.56	2,981.80	3,165.85	28,299.90	42.88	762.18	.....	.....	27,537.72
Marvel Loch	3,505.50	7,434.50	22,040.35	4,911.52	34,386.37	9.81	2,111.90	8,755.95	45,254.22	12.91	3,714.31	.....	.....	41,539.91
Meekatharra	5,290.00	6,882.32	25,682.26	5,271.27	37,835.85	7.15	7,916.77	15,793.88	61,546.50	11.63	3,171.95	.....	.....	58,374.55
Menzies	271.50	6,597.88	5,157.59	1,598.62	13,354.09	49.19	5,549.51	2,565.45	21,469.05	79.08	448.77	.....	.....	21,020.28
Norseman	251.00	3,548.95	2,947.91	856.79	7,353.65	29.30	806.18	1,374.74	9,534.57	37.99	247.22	.....	.....	9,287.35
Nullagine	.....	.....	898.20	109.73	1,007.93	.....	30.20	.....	1,038.13	.....	.....	.....	.....	1,038.13
Ora Banda	2,286.00	6,064.09	9,112.17	2,616.72	17,792.98	7.78	3,172.97	5,556.38	26,522.33	11.60	1,528.80	.....	.....	24,993.53
Paynes Find	74.00	777.36	963.90	443.64	2,184.90	29.53	25.71	224.71	2,435.32	32.91	80.50	.....	.....	2,354.82
Peak Hill	.....	.....	138.00	.....	138.00	.....	.....	.....	138.00	.....	.....	.....	.....	138.00
Sandstone	87.00	849.59	1,721.17	91.18	2,661.94	30.60	81.85	264.32	3,008.11	34.58	91.35	.....	.....	2,916.76
Yarri	801.00	1,285.83	7,908.60	1,479.77	10,674.20	13.33	4,468.32	2,261.57	17,404.09	21.73	1,146.08	.....	.....	16,258.01
Head Office	.....	.....	.....	.....	.....	.....	.....	.....	.....	.....	56.20	.....	.....	56.20
Sub-Total	23,360.50	79,660.43	144,147.58	44,662.32	268,470.33	9.47	53,242.32	88,811.51	410,524.16	14.48	26,615.10	.....	1,913.40	385,822.46
Marble Bar (Magnetic Plant)	26.95	.....	2,537.31	.....	2,537.31	94.15	.....	237.82	2,775.13	102.97	1,118.00	.....	.....	1,657.13
Northampton (Lead)	1,160.25	12,103.56	8,251.24	2,929.88	23,284.68	20.07	7,298.88	5,282.73	35,866.29	30.91	2,601.26	.....	.....	33,265.03
Total	29,547.70	91,763.99	154,936.13	47,592.20	294,292.32	9.96	60,541.20	94,332.06	449,165.58	15.20	30,334.36	1.03	1,913.40	420,744.62

OPERATING LOSS \$418,831.22

## Schedule No. 5

## STATEMENT OF RECEIPTS AND EXPENDITURE FOR THE YEAR ENDED 31st DECEMBER, 1971

## Cyaniding

Battery	Tons Treated	Management and Supervision	Wages	Stores	Total Working Expenditure	Cost per Ton	Repairs and Renewals	Sundries	Gross Expenditure	Cost per Ton	Receipts	Receipts per Ton	Profit	Loss
Coolgardie	561.00	\$ 1,550.97	\$ 1,552.18	\$ 756.15	\$ 3,859.30	\$ 6.88	\$ 2,289.18	\$ 315.30	\$ 6,463.78	\$ 11.52	\$ 1,642.98	\$ 2.93	.....	\$ 4,820.80
Kalgoorlie	3,600.00	5,041.83	14,200.43	5,484.77	24,727.03	6.87	10,881.12	227.21	35,785.36	9.94	7,571.23	2.10	.....	28,214.13
Leonora	3,300.00	4,240.11	11,334.02	4,827.17	20,401.30	6.18	7,683.21	699.91	28,784.42	8.72	6,265.41	1.90	.....	22,519.01
Marble Bar	348.00	.....	1,121.83	269.51	1,391.34	4.00	1,066.30	.....	2,457.64	7.06	1,551.16	4.46	.....	906.48
Marvel Loch	3,772.00	219.20	13,496.52	3,245.50	16,961.22	4.50	6,870.11	524.20	24,355.53	6.46	9,013.04	2.39	.....	15,342.49
Norseman	660.00	2,719.40	2,040.27	962.01	5,721.68	8.67	1,225.87	.....	6,947.55	10.53	2,668.03	4.04	.....	4,279.52
<b>Total</b>	<b>12,241.00</b>	<b>13,771.51</b>	<b>43,745.25</b>	<b>15,545.11</b>	<b>73,061.87</b>	<b>5.97</b>	<b>29,965.79</b>	<b>1,766.62</b>	<b>104,794.28</b>	<b>8.56</b>	<b>28,711.85</b>	<b>2.35</b>	<b>.....</b>	<b>76,082.43</b>

Interest Paid to Treasury	.....	4,320.00	4,320.00
	<u>104,794.28</u>	<u>24,391.85</u>	<u>80,402.43</u>
Operating Loss	.....		<u>80,402.43</u>

**STATE BATTERIES**

**TRADING AND PROFIT LOSS ACCOUNT FOR THE YEAR ENDED 31st DECEMBER, 1971**

1970		1971
\$		\$ \$
261,417	Trading Costs—	
57,516	Wages .....	304,217
73,479	Stores .....	63,137
115,359	Repairs, Renewals and Battery Spares .....	90,507
	General Expenses and Administration .....	100,419
<u>507,771</u>		<u>558,280</u>
58,705	Earnings—	
	Milling and Cyaniding Charges .....	59,046
<u>449,066</u>	Operating Loss for the Year .....	<u>499,234</u>
61,822	Other Charges—	
30,524	Interest on Capital .....	61,916
13,768	Depreciation .....	29,494
	Superannuation—Employers Share .....	18,233
<u>106,114</u>		<u>109,643</u>
<u>555,180</u>	Total Loss for the Year .....	<u>608,877</u>

**BALANCE SHEET AS AT 31st DECEMBER, 1971**

31st December, 1970	Funds Employed	31st December, 1971
\$		\$ \$
1,469,820	Capital—	
303,694	Provided from General Loan Fund .....	1,471,920
	Provided from Consolidated Revenue Fund .....	322,195
<u>1,773,514</u>		<u>1,794,115</u>
57,244	Reserves—	
27,572	Commonwealth Grant—Assistance to Gold Mining Industry .....	57,244
	Commonwealth Grant—Assistance to Metalliferous Mining .....	27,572
<u>84,816</u>		<u>84,816</u>
2,513,392	Liability to Treasurer—	
	Interest on Capital .....	2,575,308
6,549,748	Other Funds—	
	Provided from Consolidated Revenue Fund (Excess of payment over collections) .....	7,034,396
<u>10,921,470</u>		<u>11,488,635</u>
10,047,584	Deduct—	
555,180	Profit and Loss :	
	Loss at Commencement of Year .....	10,602,764
	Loss for Year .....	608,877
<u>10,602,764</u>	Total Loss from Inception .....	<u>11,211,641</u>
<u>318,706</u>		<u>276,994</u>

**Employment of Funds**

1,762,331	Fixed Assets—	
1,511,398	Plant, Buildings and Equipment .....	1,782,932
	Less Depreciation .....	1,540,892
<u>250,933</u>		<u>242,040</u>
19,923	Current Assets—	
82,315	Debtors .....	17,372
13,784	Stores .....	82,327
	Battery Spares .....	9,627
25,565	Purchase of Tailings :	
72,120	Treasury Trust Account .....	27,096
11,008	Tailings not treated .....	70,665
	Estimated Gold Premium .....	12,460
<u>224,715</u>		<u>219,547</u>
<u>475,648</u>	Total Assets .....	<u>461,587</u>
18,813	Deduct—	
125,436	Current Liabilities :	
	Creditors .....	26,702
	Liability to Treasurer (Superannuation—Employers Share) .....	143,669
1,685	Purchase of Tailings :	
11,008	Creditors .....	1,762
	Estimated Premium Due .....	12,460
<u>156,942</u>		<u>184,593</u>
<u>318,706</u>		<u>276,994</u>

# DIVISION IV

## Annual Report of the Geological Survey Branch of the Mines Department for the Year 1971

### CONTENTS

	Page
INTRODUCTION .....	49
METRICATION .....	49
ACCOMMODATION .....	49
STAFF .....	50
OPERATIONS .....	50
Hydrology and Engineering Geology Division .....	50
Sedimentary (Oil) Division .....	51
Regional Geology Division .....	51
Mineral Resources Division .....	51
Common Services Division .....	51
ACTIVITIES OF THE COMMONWEALTH BUREAU OF MINERAL RESOURCES .....	53
PROGRAMME FOR 1972 .....	53
PUBLICATIONS AND RECORDS .....	54

### REPORTS

#### HYDROLOGY

1. Summary of aquifer and bore characteristics of the north Gnangara bore field ; by P. Balleau ..... 55
2. Saturated sands at Yenart Soak ; by P. Balleau ..... 57
3. Groundwater resources along the lower Gascoyne River—a summary ; by A. D. Allen ..... 60
4. Cretaceous—Holocene stratigraphy and structure, lower Gascoyne River, Carnarvon Basin ; by A. D. Allen ..... 66

#### ENGINEERING GEOLOGY

5. Earthquake hazard in Western Australia ; by F. R. Gordon ..... 69

#### SEDIMENTARY GEOLOGY

6. Petroleum exploration in Western Australia in 1971 ; by P. E. Playford and G. H. Low ..... 81
7. Petroleum development and production in Western Australia in 1971 ; by R. N. Cope ..... 87
8. Definitions of some new and revised rock units in the Perth Basin ; by P. E. Playford and G. H. Low ..... 88
9. Tectonic style in the southern Perth Basin ; by R. N. Cope ..... 90
10. Preliminary results of geological mapping in the Officer Basin, Western Australia, 1971 ; by D. C. Lowry, M. J. Jackson, W. J. E. van de Graaff and P. J. Kennewell ..... 94
11. The Wanna Beds—an analogue of Recent North Sea sediments ; by W. J. E. van de Graaff ..... 100

#### REGIONAL GEOLOGY

12. A recent fault scarp in the Lort River area, Ravensthorpe 1:250,000 Sheet ; by R. Thom ..... 102

#### MINERAL RESOURCES

13. A reported platinum find in the Rudall River area ; by J. G. Blockley ..... 103
14. The geology of the Eneabba area, Western Australia ; by J. L. Baxter ..... 105

#### PETROLOGY

15. The Edjudina meteorite ; by J. D. Lewis ..... 106
16. An unusual eutaxitic rock from the Precambrian Hamersley Group, Western Australia ; by A. F. Trendall ..... 109

#### GEOCHRONOLOGY

17. Apparent age, and origin, of black porcelanite of the Joffre Member ; by A. F. Trendall and J. R. De Laeter ..... 112

## LIST OF PLATES



Plate No.	Faces page
1. North Gnanagara bore field	54
2. Data plots for short screened bore 310F and for more fully penetrating bore 310G	55
3. Lower Gascoyne River : location of investigation programme and resultant cross sections	62
4. Lower Gascoyne River : groundwater contours based on cross sections and scattered bore or well data	63
5. Lower Gascoyne River : bore correlation diagram and cross sections	66
6. Lower Gascoyne River : A.—Gascoyne River No. 1 (Mooka) gamma-ray log ; B.—longitudinal profile, Gascoyne River	67
7. Western Australia : petroleum tenements as at 31st December, 1971	82
8. Western Australia : wells drilled for petroleum exploration	83
9. Topographic contours in the Perth Basin	91
10. Preliminary solid geology of the Officer Basin	94
11. A.—Air-photograph showing detail of northern extremity of fault ; B.—air-photograph showing possible sagpond caused by obstruction of creek by scarp	102
12. A. and B.—Typical development of fault scarp	103
13. Geology of the Lort River area	103
14. Geological map of the Eneabba area	105
15. Photographs and photomicrographs of the Eadjudina meteorite	108
16. Photomicrographs of chondrules	109
17. Photograph and sketch of thin section of sample 15640	110
18. Photographs of textural details of thin section	111
19. Macrophotographs and microphotographs of porcelanites	114
20. Microphotographs of first porcelanite	115

## LIST OF FIGURES

Figure No.	Faces page
1. Index map showing areas and locations described in Annual Report for 1971	47
2. Progress of 1:250,000 or 4-mile geological mapping at the end of 1971	53
3. Step-test data plots with Sheahan's type curve match points	56
4. Yenart Soak : locality plan	57
5. Yenart Soak : isometric fence diagram of auger hole field	58
6. Weekly water levels, Bolgart	59
7. Lower Gascoyne River : location plan showing catchment, generalized geology and isohyets	60
8. Seismic zone and geological structure	70
9. 1970 earthquake risk zoning of Western Australia	71
10. Distribution of earthquake epicentres for the period 1961 through 1967	72
11. Relationship of tectonic belts, seismic zones, and global seismicity	72
12. Record of damage and earthquake effects to population centres from 1904 to 1965	73
13. Isoseismal maps of Western Australia's earthquakes	75
14. Dongara area : showing wells drilled for petroleum exploration	82
15. Cape Range-Rough Range area : showing wells drilled for petroleum	83
16. The Dongara-Perth-Pinjarra gas pipeline	88
17. Structure contour map	90
18. Cross sections through Whicher Range No. 1	91
19. Geomorphic features	92
20. Correlation diagram of stratigraphic units in the Officer Basin	98
21. Large-scale beta cross-stratification with superimposed smaller cross-sets	100
22. Comparison of fault traces	102
23. Location diagram showing position relative to South West Seismic Zone	102
24. Sketch map : reported platinum deposits, Rudall River area	103
25. Geomorphology of the Eneabba area	104
26. Physical properties of sand in the Eneabba area	106
27. Isochron plots for the data of Table 1	114

GEOLOGICAL SURVEY OF WESTERN AUSTRALIA  
 INDEX MAP SHOWING  
 AREAS AND LOCALITIES DESCRIBED  
 IN ANNUAL REPORT 1971

NOTE Report numbered 6 in the contents list covers the sedimentary basins of the State; report numbered 5 covers the whole State.

-  Area covered and report number
-  1 Locality covered and report number

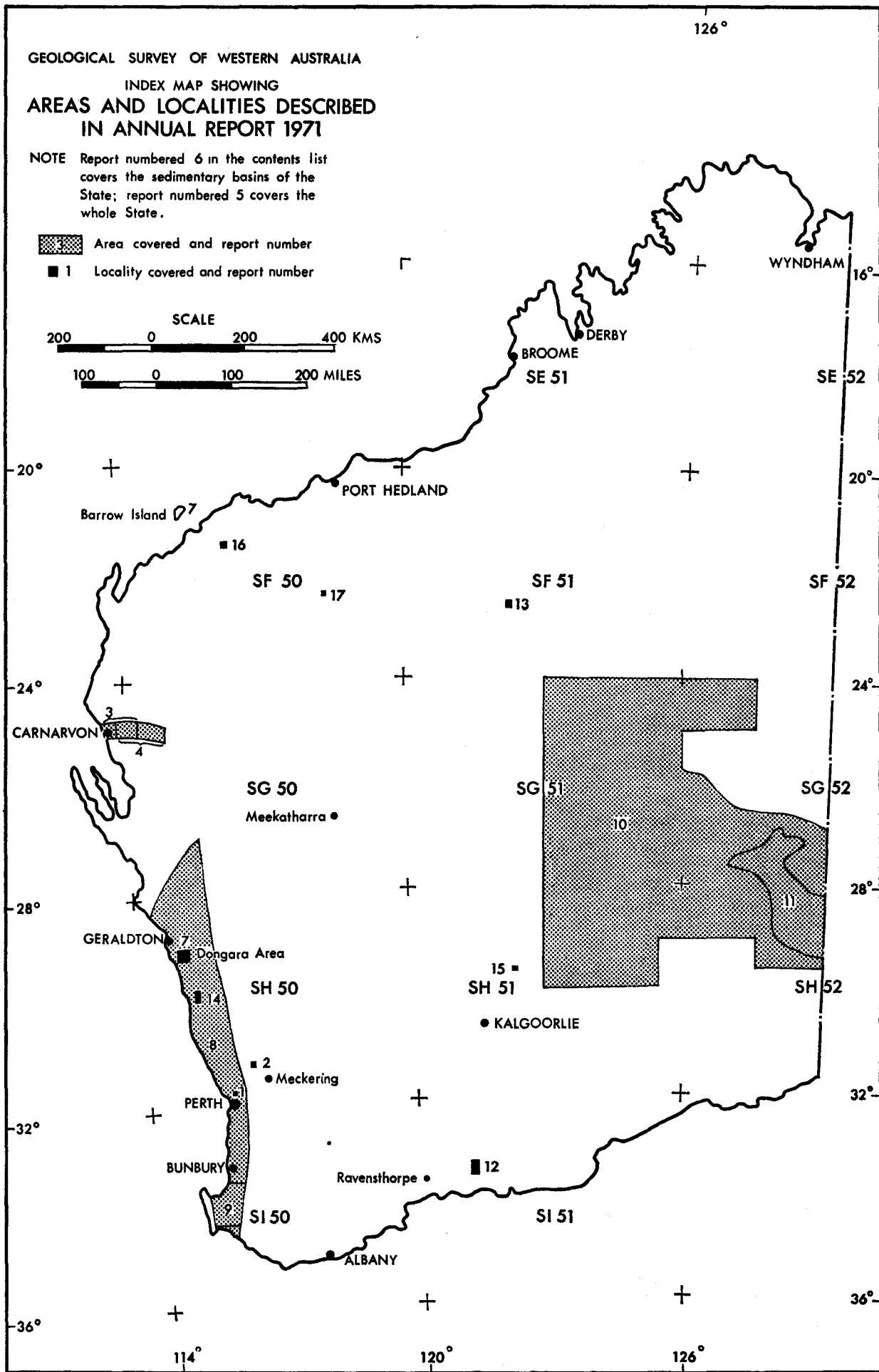
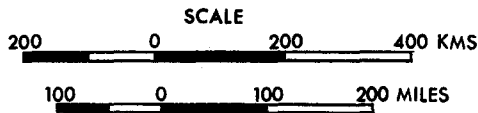


Figure 1

12878

Index Map showing areas and localities described  
 in Annual Report 1971



# DIVISION IV

## Annual Report of the Geological Survey Branch of the Mines Department for the Year 1971

### *The Under Secretary for Mines*

For the information of the Honourable Minister for Mines, I submit my report on the activities of the Geological Survey of Western Australia during 1971, together with some of the reports on investigations made for departmental purposes.

### INTRODUCTION

The mineral exploration boom which this State has experienced in recent years subsided abruptly during the latter half of 1971. All booms must end but the ending of this one was hastened by the falling world metal prices, international monetary problems, nationalization of mining interests in other countries and the unethical practices of some Australian companies.

While the decrease in exploration activity has been rapid, it is considered that the decline will cease shortly and then there will be a gradual increase to a sane and sensible level.

Iron ore exploration has continued, with the completion of test drilling of such deposits as McCamey's Monster, Rhodes Ridge, Marillana, Koodaiderie and Weld Range. No doubt when the export market for iron ore recovers, new contracts will be made for the export of some of these deposits.

Feasibility studies have been completed for Pacminex and Alwest bauxite projects to the north of Perth and near Bunbury respectively, while construction at the Amax bauxite project in the Kimberley is ready to commence. All projects are proceeding at a slower pace due to oversupply of alumina on the world market at present.

Similarly, progress with nickel development has been retarded because of oversupply of the metal. Two important new finds were made this year, one by Selcast near Agnew and the other at Windarra South by Union Oil. Both are examples of fruitful results of consistent detailed exploration, particularly the latter which is under at least 46 metres (150 ft) of overburden. Other occurrences of nickel mineralization have been reported but none has yet proven to be a mineable proposition. In summary, nickel is being produced at Kambalda, Nepean and Scotia. Mine development is being undertaken at Mount Windarra (Poseidon), Carr Boyd, Spargoville, Widgiemooltha, Redross and Wannaway, while high-grade ore bodies at Agnew and Windarra South and a large low-grade deposit at Mount Keith appear to be potential mines.

In the early part of the year the renewed interest in mineral sands continued with exploration in the Eneabba area, which could be developed into two or three mines. Again falling demand for these minerals has caused the cessation of activity in many parts of the State.

There has been an interest in the exploration for coal in the Perth and Canning Basins, but without much success. A find near Eneabba is still being tested. It is a Jurassic coal and probably similar in quality to that from Collie.

Exploration for oil and gas was more active this year and very encouraging gas finds were made on the Northwest shelf by the Burmah-Woodside group at Scott Reef, North Rankin, Rankin and Angel wells. This area should prove to be one of the world's major gasfields. This is an extremely important find for this State which has been so deficient in natural fuels until now. Care should be taken to preserve ample for the State's future needs.

Exploration is continuing at a slower tempo but in a more thorough manner for other minerals such as copper, lead, zinc, chromium, diamonds, fluorite, coal and uranium. Several small finds of low-grade sporadic uranium mineralization have been made in the calcrete drainages of the Laver-ton-Wiluna area.

Due to the decrease in the activity of the Survey as a result of staff shortages, only one lecture followed by a field excursion was conducted in 1971. This was on the Edjudina 1:250,000 Geological Sheet which attracted, despite the recession, a record crowd of over 220 which more than filled the lecture theatre at the Kalgoorlie School of Mines and somewhat overwhelmed the excursion organization. If such popularity continues new arrangements will be needed for future occasions. Two or three such lectures are planned for 1972.

### METRICATION

In the Annual Report for 1970 all measurements were immediately followed by their metric equivalents, within brackets, in anticipation of ultimate metrication of all work. In this present report the converse practice is followed as a further step along the same path; metric units are used wherever possible, with their non-metric equivalents following immediately within brackets. In some instances, for example petroleum reserve and production statistics, it has been impracticable to apply this policy, for reasons noted in the appropriate text. After publication of this report the Geological Survey will cease to show non-metric equivalents, and with a few minor exceptions of the type just noted, all published work will use only metric units.

### ACCOMMODATION

The Survey has settled down in the very good accommodation provided in Mineral House. With all positions expected to be occupied shortly the space provided for the Survey will be fully used. As a result of the boom more filing and library space will be required within 2 or 3 years.

The finance requested for the extension of the Dianella core library was not provided this year again. This store is now extremely short of space, resulting in its becoming very cluttered and inefficient to operate.

## STAFF

Early in the year the Branch continued to lose staff, in particular two supervising geologists, Dr. J. L. Daniels and Mr. F. R. Gordon, both of whom gave valuable service while with the Survey.

About mid-year there was a sudden change in the staff situation resulting in there being many applicants for positions, particularly those at lower levels. By the end of the year all the vacancies except one had been committed, and so in 1972 the Survey should be at full strength.

### PROFESSIONAL

#### Appointments

Name	Position	Effective Date
Leech, R. E. J., B.Sc. (Hons.)	Geologist, Level 1	5/1/71
Lipple, S. L., B.Sc. (Hons.)	Geologist, Level 1	4/2/71
van de Graaff, W. J. E., Dr. (Leiden)	Geologist, Level 1	9/3/71
Commander, D. P., B.Sc.	Geologist, Level 1	11/3/71
Commander, S. J., B.Sc. (Hons.)	Geologist, Level 1	11/3/71
Grey, K., M.Sc.	Geologist, Level 1	29/3/71
Balleau, W. P., B.A.	Geologist, Level 1	6/4/71
Forth, J. R., B.Sc. (Hons.)	Geologist, Level 2	18/5/71
Boegl, J. C., D.Sc.	Geologist, Level 1	20/5/71
Hooper, K., Ph.D.	Palaeontologist, Level 4	21/6/71
Playford, P. E., Ph.D.	Supervising Geologist, Level 5	12/7/71
Libby, W. G., Ph.D.	Petrologist, Level 4	24/8/71
Vogwill, R. I. J., M.Sc.	Geologist, Level 1	27/10/71
Mather, R. P., B.Sc. (Hons.)	Supervising Geologist, Level 5	1/11/71
Crowe, R. W. A., B.A. (Hons.)	Geologist, Level 1	24/11/71
Nicholson, J., Ph.D.	Geologist, Level 1	8/12/71
Cockbain, A. E., Ph.D.	Senior Geologist, Level 3	16/12/71

#### Resignations

Clure, V. S.	Geologist, Level 1 (Temp.)	1/71
Gordon, F. R.	Supervising Geologist, Level 4	22/1/71
Ingram, B. S.	Geologist, Level 1	11/3/71
Paterson, B. B.	Geologist, Level 1	22/4/71
Daniels, J. L.	Supervising Geologist, Level 5	18/6/71
Lowry, D. C.	Geologist, Level 2	8/10/71

#### Promotions

Allen, A. D.	Senior Geologist, Level 3	13/1/71
Blockley, J. G.	Supervising Geologist, Level 5	17/3/71
Marcos, G. W. A.	Geologist, Level 2	13/8/71
Cope, R. N.	Production Geologist, Level 4	14/9/71

### CLERICAL AND GENERAL

#### Appointments

Bradley, T. R.	Geological Assistant	18/1/71
Snell, J. F.	Assistant	25/1/71
Kerr, R.	Laboratory Assistant	2/2/71
Colliss, B. K.	Geological Assistant	3/3/71
Chaplyn, J. M.	Library Assistant	30/3/71
Hadley, P.	Technical Assistant	5/5/71
Ash, L.	Technical Assistant	10/5/71
Ambridge, P.	Assistant	17/5/71
Stevens, M. R.	Laboratory Assistant	24/5/71
Cusan, M.	Library Assistant	9/8/71
O'Rourke, G. R.	Geological Assistant	8/10/71

#### Transfers In

Smeed, M.	Assistant	8/10/71
Lyons, W. A.	Clerk	7/12/71

#### Transfers Out

Nicholls, T. J.	Geological Assistant	21/4/71
Keeley, T.	Clerk	23/7/71

#### Resignations

Petzold, V.	Laboratory Assistant	25/2/71
D'Silva, A.	Clerk	5/3/71
Snell, J. F.	Assistant	18/5/71
Drennan, K.	Library Assistant	6/8/71
Ambridge, P.	Assistant	17/9/71

## OPERATIONS

### HYDROLOGY AND ENGINEERING GEOLOGY DIVISION

E. P. O'Driscoll (Chief Hydrogeologist), T. T. Bestow, R. P. Mather (Supervising Geologists), K. Berliat, A. D. Allen (Senior Geologists), C. C. Sanders, G. W. A. Marcos, C. J. R. Forth, W. P. Balleau, W. A. Davidson, A. S. Harley, R. Barnes, R. I. J. Vogwill, D. P. Commander, R. E. J. Leech, and J. Nicholson.

### Hydrology

Deep exploratory drilling across the Perth Basin was resumed along the Watheroo-Jurien Bay cross section, bores being constructed at five sites. Operational techniques have markedly improved with the use of sidewall coring equipment, new methods for recovering true water samples and hydraulic heads, and geophysical logging.

Investigation of the shallow groundwater potential in alluvial material in the De Grey River area has continued satisfactorily, and a further 11 bores have been drilled. Substantial areas of potable water are being delineated and several of the bores have been pumped at 113 to 136 cubic metres per hour (25,000-30,000 gph) with small drawdowns.

The lower reaches of the Gascoyne River as far upstream as 79 kilometres (49 miles) from the estuary have been the subject of an intensive study which has established the existence of two levels of alluvium beneath the river, and the amount of potable water available for Carnarvon has been calculated.

A new senior geologist position has been created specifically to meet the needs of the Metropolitan Water Board in hydrogeological investigations, particularly the detailed assessment of groundwater resources in the Perth area.

Drilling and test pumping in the North Gnangara production field has now been completed and a comprehensive analysis made of the aquifer characteristics. Fifteen pumping bores were drilled and tested at rates which averaged over 110 cubic metres per hour (24,000 gph). Six bores were also test pumped at over 113 cubic metres per hour (25,000 gph) in the Gwelup area for the Metropolitan Water Board.

Additional drilling has been carried out west of Muchea in continuation of the Geological Survey's programme of work to test the northern extension of the Bassendean Sands.

The recent upsurge in mineral exploration has resulted in the search for very large volumes of water in several districts, mostly with low rainfall. The companies have employed consultants, but because of the involvement of the Government, considerable time has been spent by Geological Survey officers in consultations and checking of work in seven areas.

Because interest is increasingly turning towards the long-term availability of large volumes of groundwater, the mathematical analysis of test pumping results has become a major activity. Re-appraisals have been made of the Yule River area (Port Hedland), Allanooka (Geraldton), and Millstream (Dampier). The Paroo calcareted drainage was partly investigated in 1969; 10 more shallow bores were drilled and further test pumping was done this year. This has established that possibly 11,000 cubic metres per day (2.5 million gpd) of potable water should be available from Paroo, extra to that which can be obtained from the calcrete near Wiluna itself.

It was suggested to the Department of Public Works that the strongly jointed Proterozoic volcanic rocks underlying the basin of the Harding River south of Mount Roe might contain large volumes of potable water. One exploratory bore now under construction is reported as having a big supply and the whole area appears to have considerable potential.

Advice regarding siting of deep bores, logging, and sometimes pump-test analysis was given to a number of organizations, including the Department of Public Works and the Metropolitan Water Board.

Thirty reports were written for other departments, and 27 for private landholders.

### Engineering Geology

During the year work was restricted because of shortage of staff. The surface geology was remapped at South Dandalup Dam Site after stripping, and the geology was then progressively mapped as

excavation proceeded. Geological maps of two low diversion dams were also prepared, one on the South Dandalup River near Pinjarra and the other on the lower Helena River. A prospective dam site on the South Canning River has also been mapped in detail, with the assistance of seismic refraction work to help delineate the bedrock profile.

An assessment of earthquake hazards in Western Australia has been published, the main purpose being as a guide in formulating building construction standards.

Four reports were issued after field reconnaissances of prospective dam sites in the Pilbara.

#### SEDIMENTARY (OIL) DIVISION

P. E. Playford (Supervising Geologist), R. N. Cope (Production Geologist), A. E. Cockbain and G. H. Low (Senior Geologists), J. C. Boegli, R. W. A. Crowe, and W. J. E. van de Graaff.

Information obtained from oil exploration and production activities of companies operating in Western Australia was collated and appraised. A report was prepared on the potential of the Palm Valley and Mereenie gas fields as sources of gas for Western Australia compared with that of alternative sources within the State.

Compilation of surface geological maps of the Perth Basin is close to completion, and subsurface studies of the basin were continued. Regional mapping of the Officer Basin in collaboration with the Bureau of Mineral Resources was carried out, with the use of a helicopter, over an area of about 240,000 square kilometres (92,700 miles<sup>2</sup>). Mapping of the basin will be completed during 1972. Detailed studies of the Devonian reef complexes in the Bugle Gap area and elsewhere on the Lennard Shelf were continued. Two reports were prepared on the results of a deep-drilling programme for coal carried out during the previous year in the Collie field.

#### REGIONAL GEOLOGY DIVISION

I. R. Williams (Senior Geologist), P. C. Muhling, C. F. Gower, R. Thom, and J. A. Bunting.

##### Eastern Goldfields area

Geological mapping was completed on the Ravenshorpe and Lake Johnston 1:250,000 Sheets and compilation is in progress.

Compilation and drawing have been completed on the following 1:250,000 Sheets: Norseman, Zanthus, Balladonia, Malcolm-Cape Arid, Esperance-Mondrain Island and Edjudina.

##### Murchison area

Yalgoo field mapping is complete and compilation is in progress.

Murgoo has been compiled and is being drawn.

##### General

The new State Geological map has been compiled and is being drawn.

Work has commenced on the Eastern Goldfields Bulletin and the production of the Kalgoorlie and Esperance 1:1,000,000 Sheets.

The progress of geological mapping at 1:250,000 scale to the end of 1971 is shown in Figure 2.

#### MINERAL RESOURCES DIVISION

J. G. Blockley (Supervising Geologist), J. D. Carter (Senior Geologist), J. L. Baxter, and S. L. Lipple.

Compilation of the results of a study of the State's tin deposits continued, together with further laboratory work on the tin granites.

An assessment was made of the mineral sand resources of Eneabba and the south coast.

Frequent requests for information on limestone and construction materials in the Pilbara region necessitated a survey of the availability of these materials in that area.

A system of indexing and storing statutory reports on mineral exploration was designed and is operating satisfactorily. The design of a punch-card system to facilitate retrieval is well advanced.

Other work included an assessment of exploration done on iron ore reserves and inspections of deposits, or reported occurrences, of graphite, nickel and platinum.

#### COMMON SERVICES DIVISION

*Petrology*—(W. G. Libby, J. D. Lewis, and R. Peers)

Services provided by the petrology section to all divisions of the Geological Survey included 38 formal petrologic reports as well as many informal discussions in the office and in the field. Miss Peers completed a special study of the Leeuwin-Naturaliste block and concluded studies of the Geraldton-Northampton area. Special studies of syenitic rocks, an ultramafic lava and the Edjudina meteorite in co-operation with geologists of the Regional Geology Division were conducted.

Late in the year Dr. Libby assumed the vacant post of Petrologist. Efforts were resumed in the direction of providing computer storage and retrieval of rock and mineral data acquired by the Survey.

The section continued to provide direct service to the public through the Technical Information Office. The laboratory staff prepared more than 1,600 thin sections as well as numerous polished sections, mineral separations and sand grading analyses. Equipment acquired at the end of the year should increase efficiency in producing thin sections.

Geochronologic liaison with the Western Australian Institute of Technology continued through 1971. As in previous years chemical, mineralogical and X-ray diffraction work carried out at the Government Chemical Laboratories has materially assisted many of the projects dealt with.

*Palaeontology*—(K. Hooper, J. Backhouse, and K. Grey)

Routine palynological examination of sludge samples from boreholes for the Hydrology Division has continued to occupy the major portion of time during 1971.

A total of 63 file reports were prepared of which 48 were palynological, 16 were micropalaeontological and 2 were macropalaeontological.

Routine palynology of the Watheroo line of boreholes has continued throughout the year, as has work on the catalogue of Western Australian microplankton. A palaeontologist accompanied a Bureau of Mineral Resources field party to the Carnarvon Basin, collecting outcrop samples from Mesozoic and Cainozoic type sections.

A preliminary examination of the microfaunas of the Carnarvon Basin samples has been completed, and more detailed microfaunal and biostratigraphic studies are now being carried out by Dr. K. Hooper who joined the Survey as Officer-in-Charge of the Palaeontology section in May.

A study of Devonian Brachiopoda from Bugle Gap has been commenced.

*Geophysics*—(D. L. Rowston and I. R. Nowak)

Seismic refraction and resistivity work on the Port Hedland Town Water Supply project was concluded with an additional 19 kilometres (12 miles) of traverse. This integrated operation of hydrogeology, geophysics and concurrent drilling has proved most successful.

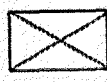




A seismic refraction survey failed to locate significant concealed river channels in the Moolyella tin field near Marble Bar.

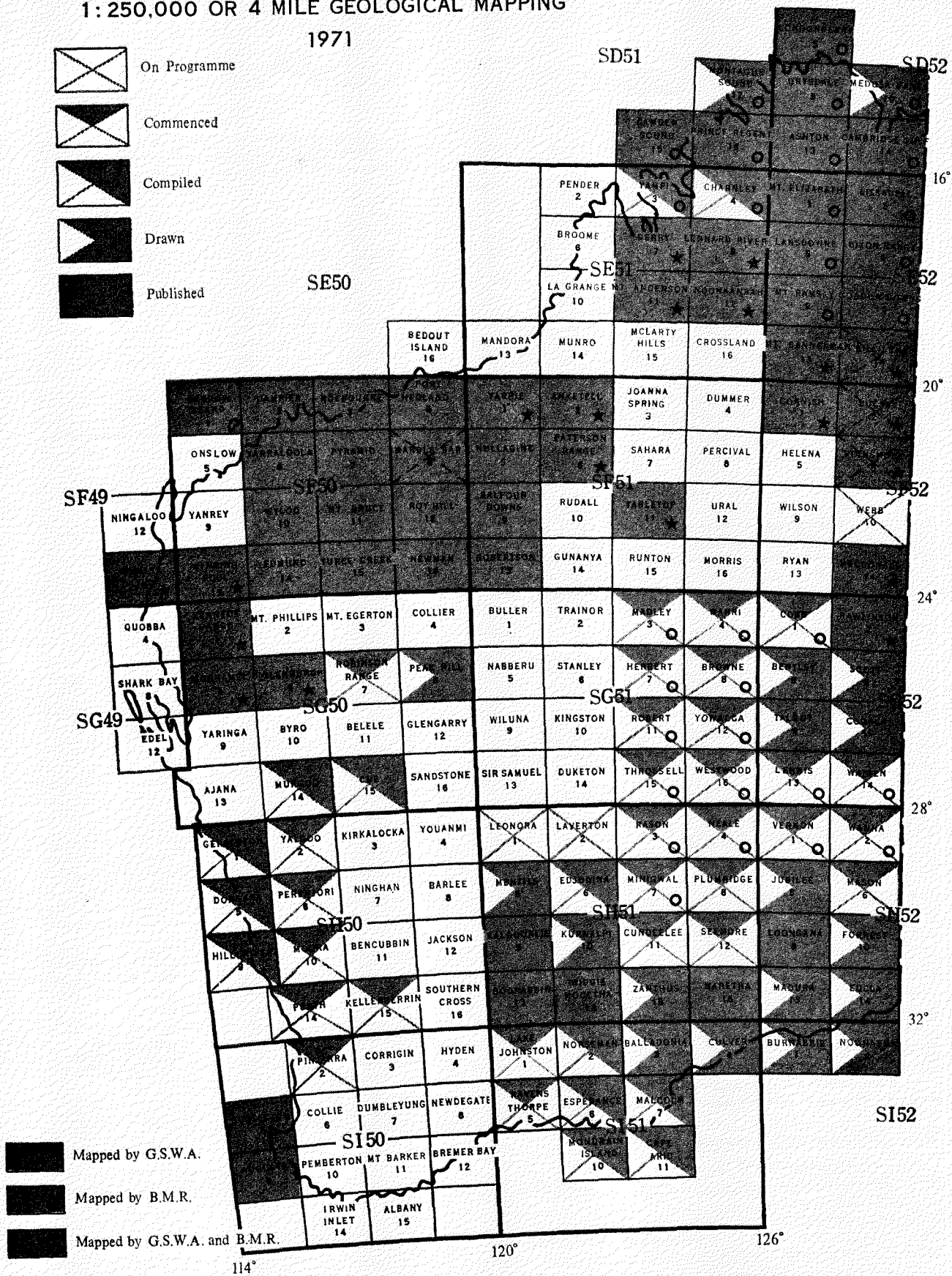
Engineering seismic work provided useful information to augment a geological appraisal of the South Canning Dam Site and increase in activity in this field of application is anticipated.

# GEOLOGICAL SURVEY OF WESTERN AUSTRALIA

## 1:250,000 OR 4 MILE GEOLOGICAL MAPPING

1971

-  On Programme
-  Commenced
-  Compiled
-  Drawn
-  Published



Broken lines on shading indicates remapping

Figure 2

An experimental study of resistivity soundings with Wenner and Schlumberger arrays, using a variety of instruments and under different surface conditions was made for C.S.I.R.O. at their Yalanbee Research Station.

During 1971, 69 logging operations were carried out on 43 individual water bores. The total footage logged, made up of records from all runs, was 24,000 metres (79,000 ft), a substantial increase over the 9,700 metres (31,760 ft) recorded in 1970.

Maintenance services were provided for Survey instruments and some 500 conductivity measurements made on field water samples.

A considerable amount of time was occupied in liaison with Public Works Department engineers on the geophysical results from several major water supply investigations.

*Technical Information*—(J. H. Thom, M. M. Toledo, S. J. Commander, and S. M. Fawcett).

This section continues to be fully occupied answering inquiries and providing advice to the public and staff. In addition it is responsible for the editing and production of reports and maps published by the Branch.

Although mineral exploration has slackened, the library continues to be used extensively by the public. It is estimated that 2,162 such persons availed themselves of the facilities during 1971 and 493 loans were made, while loans to staff amounted to 3,268.

Requisitions raised for photo-copying for the public of out-of-print publications numbered 867. Many requisitions were for several items. Requisitions raised on the Surveys and Mapping Branch for drafting services and photography for the Survey totalled 839.

Twenty-six Records and three Information Pamphlets were prepared and issued during the year, while preparation of manuscripts and proof-reading of items mentioned in the list of Publications below continued.

The Geological Museum, which attracts considerable attention, continues to be developed.

#### ACTIVITIES OF THE COMMONWEALTH BUREAU OF MINERAL RESOURCES

The geological and geophysical projects carried out by the Bureau of Mineral Resources included the following:—

- (1) Compilation of 1:250,000 Geological Sheets and bulletins on the Kimberley Division as a joint project with the Survey.
- (2) Continuation of the helicopter gravity survey of the State.
- (3) Geological mapping of the Officer Basin as a joint venture with the Survey.
- (4) Collection of fossils from Cretaceous and Tertiary sections of the northern Perth and Carnarvon Basins in conjunction with the Survey.

#### PROGRAMME FOR 1972

##### HYDROLOGY AND ENGINEERING DIVISION

###### A. Hydrology

- (1) Continuation of the hydrological survey of the Perth Basin including deep drilling.
- (2) Hydrogeological investigations and/or exploratory drilling for groundwater in the following areas:
  - (a) Muchea;
  - (b) Pilbara—continuation of drilling and assessing of De Grey River system, investigation of Deep Reach Pool area near Millstream, and drilling in the Millstream dolomites and at Woodbrook (Harding River);

(c) town water supplies for the following centres: Albany, Werillup area, Esperance-Cape Le Grand, Allanooka-Arrowsmith River, Moora and coastal towns from Cervantes to Cliff Head.

- (3) Hydrogeological investigations for the Metropolitan Water Board:
  - (a) regional studies;
  - (b) Gwelup-Whitford areas.
- (4) Kimberley Division—hydrogeological assistance to pastoralists as requested.
- (5) Continuation of bore census work in selected areas.
- (6) Miscellaneous investigations as requested by Government departments and the public.

###### B. Engineering Geology

- (1) Pilbara—initial reconnaissance of possible dam sites followed by mapping and drilling where considered advisable.
- (2) Reconnaissance investigations of dam sites, on Ashburton River, Turee Creek and Murchison River.
- (3) Collie area—investigation of possible dam sites.
- (4) Upper Helena Dam Site—geological mapping if construction commences.
- (5) South Canning Dam Site—continuation of investigatory drilling and progress mapping during construction if needed.
- (6) Lower Wungong Dam Site—reappraisal of previous work and comparison studies with South Canning.

##### SEDIMENTARY (OIL) DIVISION

- (1) Maintain an active interest in the progress and assessment of oil exploration in Western Australia.
- (2) Evaluate oil and gas discoveries and assess the resources of the State.
- (3) Complete the preparation of the Explanatory Notes of the Perth Basin 1:250,000 Sheets and continue the subsurface study of the Perth Basin and preparation of the Bulletin.
- (4) Continuation of compilation and mapping of the Officer Basin in conjunction with the Bureau of Mineral Resources.
- (5) Continue studies of the Devonian of the Canning Basin. This will include drilling in the Bugle Gap-Fitzroy Crossing area and conodont sampling in conjunction with the Bureau of Mineral Resources.

##### REGIONAL GEOLOGY DIVISION

- (1) Compilation of the Lake Johnston, Ravensthorpe and Yalgoo 1:250,000 Sheets.
- (2) Commencement of field mapping of the Rason (Precambrian portion), Laverton and Leonora 1:250,000 Sheets.
- (3) Commencement of field mapping of the Billiluna, Lucas, Stansmore and Webb 1:250,000 Sheets in conjunction with the Bureau of Mineral Resources. (Includes some re-mapping).
- (4) Complete mapping of Neale, Plumridge, Seemore, Cundelee and Minigwal 1:250,000 Sheets.
- (5) Re-assessment of the regional geology of the Eastern Goldfields.

##### MINERAL RESOURCES DIVISION

- (1) Completion of mineral resources bulletin on the tin deposits of Western Australia.
- (2) Re-map the Marble Bar 1:250,000 Sheet.
- (3) Field mapping of the Darling Range area on 1:250,000 scale and commencement of a study of the bauxite occurrences and potential.

- (4) Assessment of the vanadium, chromium, tungsten and molybdenum deposits of Western Australia.
- (5) Revision of the copper deposits bulletin.
- (6) Miscellaneous investigations as required.

#### PUBLICATIONS AND RECORDS

##### Issued during 1971

- Annual Report, 1970.  
 Publications Catalogue, 1971.  
 Bulletin 121: Devonian corals from the Canning Basin, Western Australia.  
 Geological maps 1:50,000, Perth Metropolitan area (4 sheets).  
 Geological map of Cambridge Gulf 1:250,000 Sheet (SD/52-14 International Grid) with explanatory notes.  
 Geological map of Drysdale-Londonderry 1:250,000 Sheets (SD/52-5 and 9 International Grid) with explanatory notes.  
 Geological map of Prince Regent-Camden Sound 1:250,000 Sheets (SD/51-15 and 16 International Grid) with explanatory notes.  
 Information pamphlet 8: Vanadium in Western Australia.  
 Information pamphlet 9: Gold in Western Australia.  
 Information pamphlet 10: Aluminium in Western Australia.

##### In press

- Bulletin 122: The geology of the Western Australian part of the Eucla Basin.  
 Bulletin 123: The geology of the Blackstone Area, Western Australia.  
 Mineral Resources Bulletin 9: The lead, zinc and silver deposits of Western Australia.  
 Geological map of Balladonia 1:250,000 Sheet (SI/51-3 International Grid) with explanatory notes.  
 Geological map of Bentley 1:250,000 Sheet (SG/52-5 International Grid) with explanatory notes.  
 Geological map of Cooper 1:250,000 Sheet (SG/52-10 International Grid) with explanatory notes.  
 Geological map of Culver 1:250,000 Sheet (SI/51-4 International Grid) with explanatory notes.  
 Geological map of Eucla-Noonaera 1:250,000 Sheets (SH/52-14, SI/52-2 International Grid) with explanatory notes.  
 Geological map of Forrest 1:250,000 Sheet (SH/52-10 International Grid) with explanatory notes.  
 Geological map of Geraldton 1:250,000 Sheet (SH/50-1 International Grid) with explanatory notes.  
 Geological Map of Jubilee 1:250,000 Sheet (SH/52-5 International Grid) with explanatory notes.  
 Geological map of Kurnalpi 1:250,000 Sheet (SH/51-10 International Grid) with explanatory notes.  
 Geological map of Madura-Burnabbie 1:250,000 Sheets (SH/52-13, SI/52-1 International Grid) with explanatory notes.  
 Geological map of Menzies 1:250,000 Sheet (SH/51-5 International Grid) with explanatory notes.  
 Geological map of Peak Hill 1:250,000 Sheet (SG/50-8 International Grid) with explanatory notes.  
 Geological map of Scott 1:250,000 Sheet (SG/52-6 International Grid) with explanatory notes.  
 Geological map of Talbot 1:250,000 Sheet (SG/52-9 International Grid) with explanatory notes.

##### In preparation

- Bulletin 125: The Meckering Earthquake.  
 Special publication: The Geology of Western Australia.  
 Geological maps 1:250,000 with explanatory notes, the field work having been completed: Cue, Dongara-Hill River, Edjudina, Esperance-Mondrain Is., Lake Johnston, Malcolm-Cape Arid, Norseman, Ravens-thorpe, Yalgoo.  
 Geological map 1:2,500,000 Western Australia.

##### Records produced

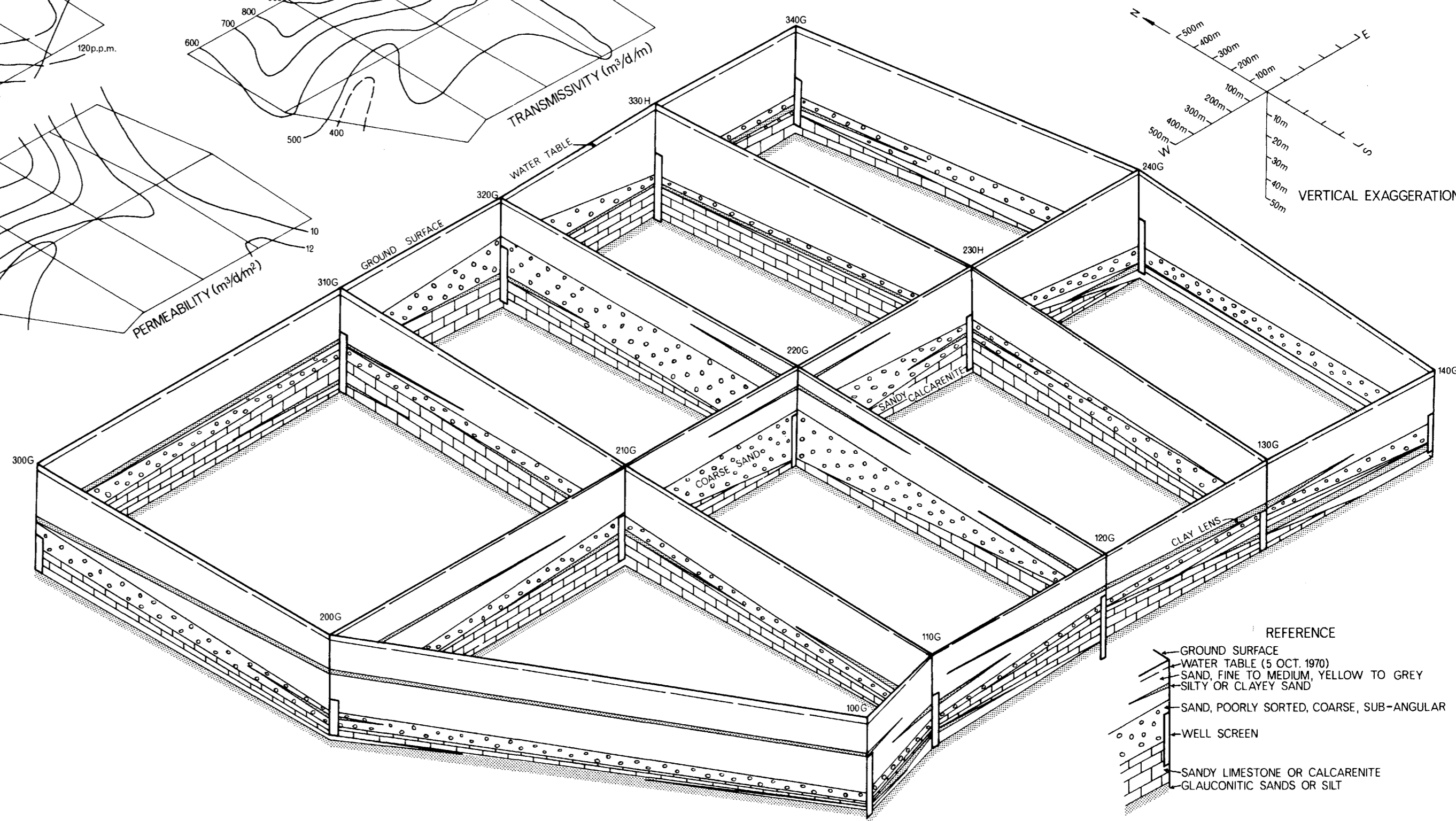
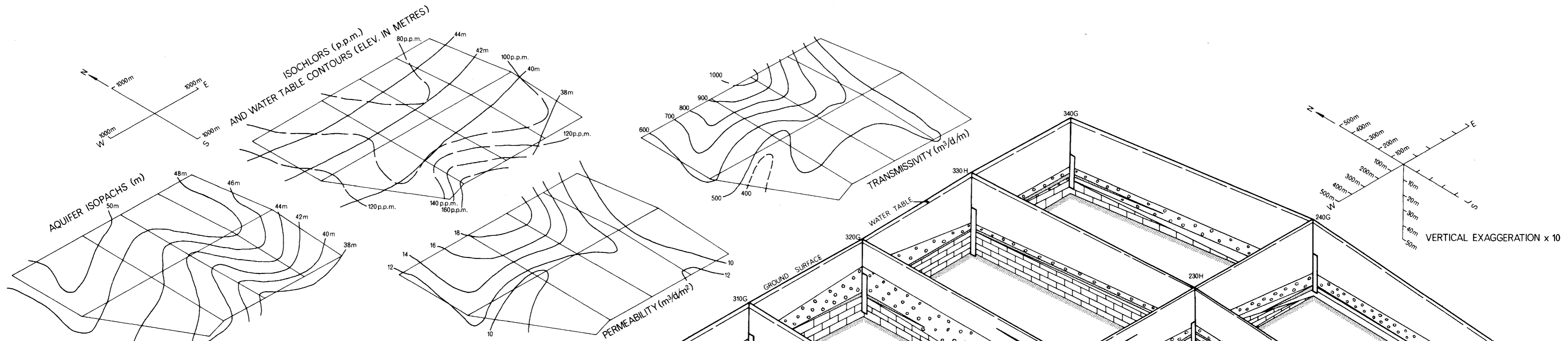
- 1971/1 The mineral resources of Western Australia, 1971, by J. H. Lord.  
 1971/2 Paroo calcrite hydrological investigation—interim report, by C. C. Sanders.  
 1971/3 Coal resources of Colleburn, Collie Basin, Menzies and Hanrahan drilling programme 1970, by D. C. Lowry (confidential).  
 1971/4 Permian palaeogeography of the South Perth Basin, by R. N. Cope (confidential).  
 1971/5 Coal reserves of the Shotts area, Collie Basin, Menzies and Hanrahan drilling programme, by G. H. Low and D. C. Lowry (confidential).  
 1971/6 Geological reconnaissance of the Officer Basin, 1970, by D. C. Lowry.  
 1971/7 Port Hedland water supply, geophysical survey, 1970, August-September, by D. L. Rowston (restricted).  
 1971/8 Hydrogeological reconnaissance of parts of Nabberu and East Murchison Mining Fields, 1970, by C. C. Sanders and A. S. Harley.  
 1971/9 Wells drilled for petroleum exploration to the end of 1970, by P. E. Playford and G. H. Low.  
 1971/10 Earthquake hazard in Western Australia, by F. R. Gordon.  
 1971/11 Roebourne groundwater investigation, geophysical survey, October 1970, by I. R. Nowak (restricted).  
 1971/12 Ilmenite and rutile resources of Eneabba and South Coast areas, W.A., 1971, by J. L. Baxter (confidential).  
 1971/13 Explanatory notes on the Murgoo 1:250,000 Geological Sheet, by J. L. Baxter.  
 1971/14 Regional hydrogeology of the Murgoo 1:250,000 Geological Sheet, by J. L. Baxter.  
 1971/15 Geological reconnaissance of Doolena Gap Dam Site, by F. R. Gordon (restricted).  
 1971/16 East Wiluna aquifer "safe yield" requirements Desert Farms (J. J. Parr) irrigation project, Wiluna, by C. C. Sanders (restricted).  
 1971/17 Geological reconnaissance of Kangan Pool Dam Site, Yule River, by F. R. Gordon (restricted).  
 1971/18 Port Hedland water supply, geophysical survey September 1970, resistivity results, by D. L. Rowston (restricted).  
 1971/19 Palm Valley and Mereenie Gas Fields, their potential as gas sources for Western Australia compared with that of alternative gas sources within the State, by P. E. Playford (confidential).  
 1971/20 South Dandalup Dam: report on geological conditions as exposed by excavation during construction, by G. Marcos (restricted).  
 1971/21 Explanatory notes on the Dongara-Hill River 1:250,000 Geological Sheets, by D. C. Lowry.  
 1971/22 Port Hedland water supply, geophysical investigations, progress report 1971 (June-July), by I. R. Nowak (restricted).  
 1971/23 Seismic refraction survey at the Brockman River, Moolyella, W. A., by I. R. Nowak (restricted).  
 1971/24 Explanatory notes on the Phanerozoic rocks of the Perth 1:250,000 Geological Sheet, by G. H. Low.  
 1971/25 Explanatory notes on the Phanerozoic rocks of the Pinjarra 1:250,000 Geological Sheet, by G. H. Low.  
 1971/26 Explanatory notes on the Edjudina 1:250,000 Geological Sheet, by I. R. Williams, C. F. Gower, and R. Thom.

##### Reports in other publications

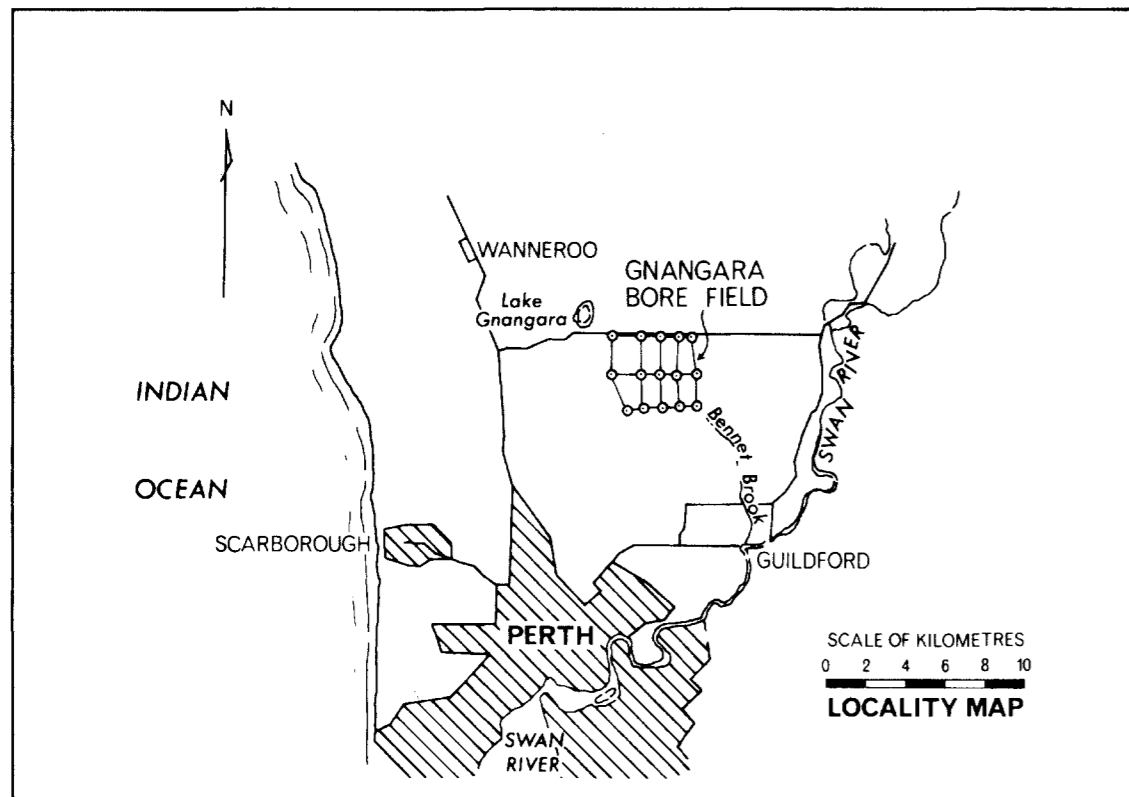
- Muhling, P. C., and De Laeter, J. R., 1971, Ages of Granitic Rocks in the Poona-Dalgara area of the Yilgarn Block, Western Australia: Geol. Soc. Australia Spec. Pub. 3, p. 25-31.  
 Williams, I. R., 1971, A Regional Synthesis of the Archaean Geology of the Eastern Goldfields, Western Australia (abstract): Geol. Soc. Australia Spec. Pub. 3, p. 152.

1st February, 1972.

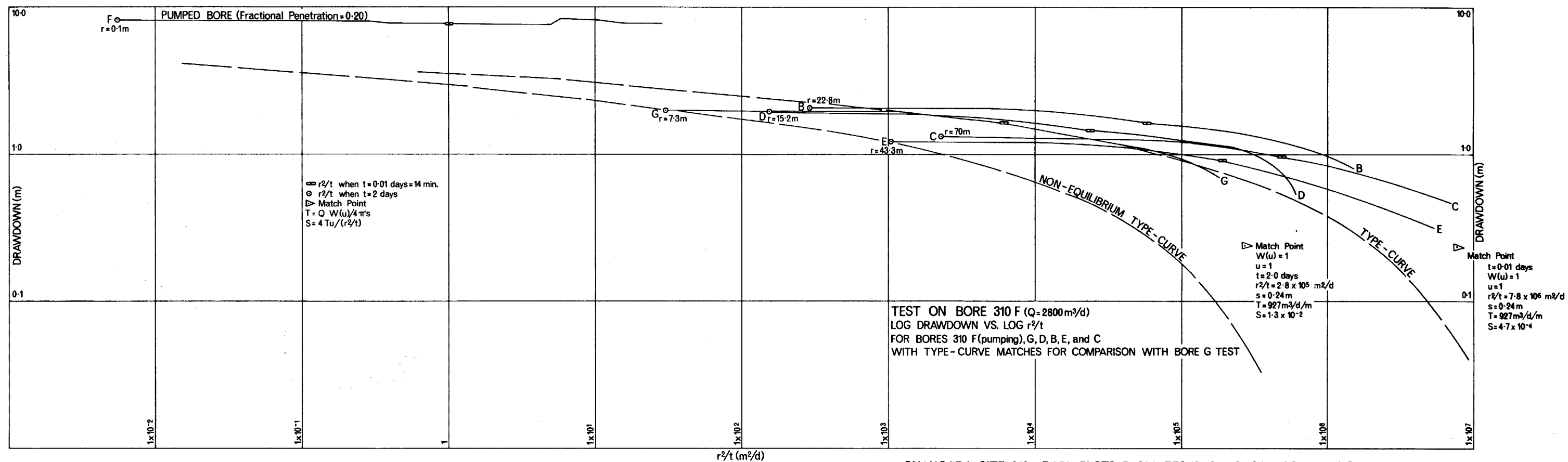
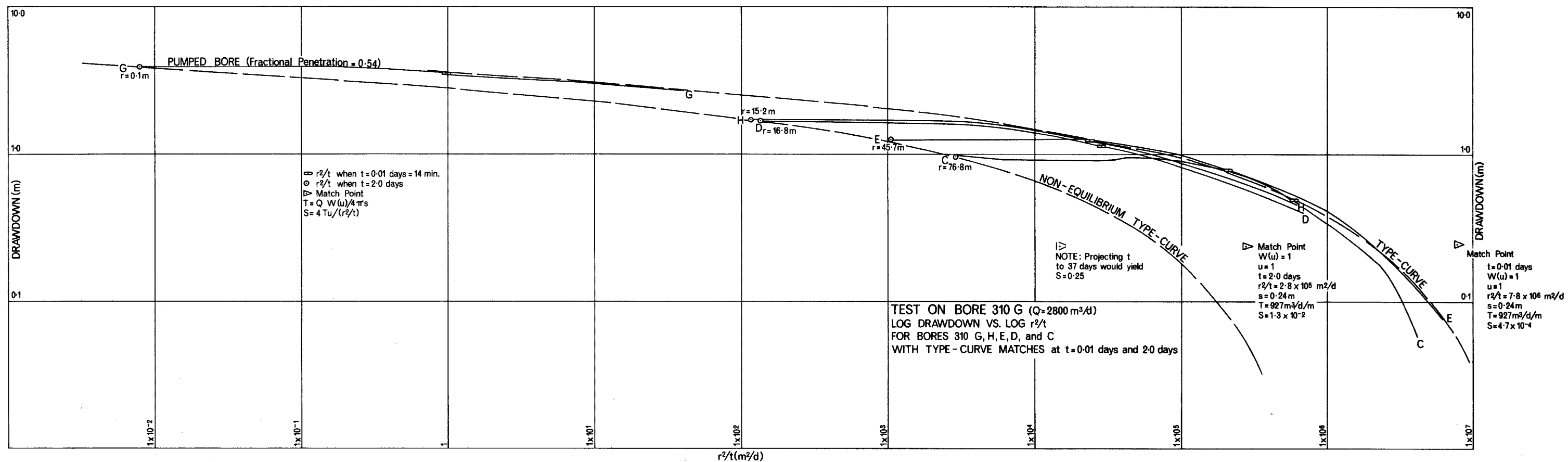
J. H. LORD,  
 Director.



- REFERENCE**
- GROUND SURFACE
  - WATER TABLE (5 OCT. 1970)
  - SAND, FINE TO MEDIUM, YELLOW TO GREY
  - SILTY OR CLAYEY SAND
  - SAND, POORLY SORTED, COARSE, SUB-ANGULAR
  - WELL SCREEN
  - SANDY LIMESTONE OR CALCARENITE
  - GLAUCONITIC SANDS OR SILT



NORTH GNAMPTARA BORE FIELD



GNANGARA SITE 310—DATA PLOTS FROM TESTS ON SHORT SCREEN BORE 310F AND LONGER SCREEN BORE 310G



# SUMMARY OF AQUIFER AND BORE CHARACTERISTICS OF THE NORTH GNANGARA BORE FIELD

by P. Balleau

## ABSTRACT

Hydraulic characteristics of the aquifer and bores in the northern Gnanagara bore field are derived using field data from step-drawdown and constant-rate pumping tests on 15 bore sites. The water-table aquifer consists of about 50 metres (165 ft) of quartz and calcarenite sands. Analyses of data from tests with bore screens in the lower half of the aquifer show effects of partial penetration and delayed yield. The use of longer bore screens reduces the effects of partial penetration such as depressed values of transmissivity, small specific capacity, and deviations from a type curve on distance-drawdown plots of observation bore response. Delayed yield causes effective storage coefficients to increase with time. Type-curve solution of step-test data shows that 13 bores are more than 80 per cent efficient at the tested pumping rate. Transmissivities over the bore field vary from 268 m<sup>3</sup>/d/m (18,000 gpd/ft) to 1,100 m<sup>3</sup>/d/m (73,000 gpd/ft) with higher transmissivities in the northernmost line of bores. Water chlorinities apparently reflect variations in transmissivity.

## INTRODUCTION

The North Gnanagara bore field is in an area of shallow groundwater about 20 kilometres (12 miles) north of Perth. Hydraulic characteristics of the aquifer and bores have been derived, using data from a 1970-1971 series of pumping tests, to aid in management of the bore field as a water source for the Perth Metropolitan Water Board.

Location and layout of the bore field are given in Plate 1 and details of the pumping-test designs are given in Table 1.

TABLE 1. DESIGN OF PUMPING TESTS AT NORTH GNANGARA BORE FIELD

Bore	Tested pumping rate (m <sup>3</sup> /day)	Aquifer thickness (m)	Distance (m) and direction from pumped bore	Screened interval (m)	Fractional penetration
100G	2,800	42	0-1	19-2-47-6	0-74
A	.....	.....	32 N	24-4-48-8	0-51
110G	2,800	43	0-1	19-2-44-2	0-55
A	.....	.....	41-2 E	24-4-47-0	0-48
120G	2,620	37	0-1	19-2-48-7	0-61
D	.....	.....	15-3 W	24-4-27-4 & 30-5-33-5	0-13
C	.....	.....	16-5 NE	24-4-27-4 & 30-5-33-5	0-13
F	.....	.....	45-7 N	24-4-27-4 & 30-5-33-5	0-13
E	.....	.....	61 W	24-4-27-4 & 30-5-33-5	0-13
130G	2,730	39	0-1	23-5-41-4	0-43
F	.....	.....	9-7 E	26-0-32-0	0-19
A	.....	.....	40-3 E	24-4-41-2	0-40
140G	2,600	38	0-1	20-4-40-2	0-50
F	.....	.....	12-2 E	29-6-34-8	0-19
A	.....	.....	42-7 E	24-4-41-2	0-42
200G	2,590	50	0-076	30-8-47-8	0-36
E	.....	.....	37-0 N	39-6-45-7	0-13
210G	1,310	48	0-1	23-5-45-7	0-50
F	.....	.....	7-9 W	23-8-30-2	0-13
D	.....	.....	16-5 SW	24-4-30-5	0-13
A	.....	.....	20-8 E	24-4-47-3	0-50
B	.....	.....	30-5 W	24-4-30-5	0-13
E	.....	.....	45-7 S	24-4-30-5	0-13
C	.....	.....	75-6 W	24-4-30-5	0-13
220G	2,800	46	0-076	21-4-46-0	0-54
A	.....	.....	17-1 NW	30-5-36-6	0-13
230H	2,800	50	0-076	22-0-46-7	0-50
E	.....	.....	23-2 NW	24-4-30-5	0-13
240G	2,800	51	0-076	23-8-48-2	0-50
C	.....	.....	15-2 W	24-4-30-5	0-13
300G	2,800	50	0-1	37-3-48-5	0-32
A	.....	.....	38-4 NE	24-4-46-0	0-43
310G	2,800	52	0-1	20-4-45-1	0-48
F	.....	.....	7-6 W	25-3-32-7	0-12
H	.....	.....	15-2 W	21-0-51-5	0-59
D	.....	.....	16-8 SW	25-9-32-0	0-12
A	.....	.....	22-6 E	24-4-29-0 & 39-6-42-7	0-15
E	.....	.....	45-7 S	25-9-32-0	0-12
C	.....	.....	76-8 W	25-9-32-0	0-12
320G	2,800	49	0-1	22-0-48-5	0-54
A	.....	.....	16-8 E	18-3-24-4 & 39-6-45-7	0-25
330G	2,800	52	0-076	22-0-52-8	0-59
A	.....	.....	14-3 E	.....	.....
340G	2,800	49	0-076	20-8-45-4	0-43
D	.....	.....	17-1 SW	28-0-34-2	0-12

NOTE: 1 m<sup>3</sup>/d = 6.55 gpm  
1 m = 3.281 ft

The aquifer is about 50 metres (165 ft) of predominantly fine to medium quartz and calcarenite sands containing mostly unconfined water from about 1.5 metres (5 ft) to a relatively impermeable clayey bottom nearly 50 metres (165 ft) below the surface. The aquifer contains three mappable lithologic units as shown in Plate 1. At the top there is a fine to medium quartz sand 18 to 38 metres (60 to 120 ft) thick, which is underlain by coarser and more angular quartz sands 5 to 18 metres (16 to 60 ft) thick. These are underlain by calcarenite 0 to 15 metres (0 to 50 ft) thick. Clayey or silty lenses are common in the lower half of the aquifer. Isopachs of the saturated aquifer show thickness increasing from about 40 metres (130 ft) at the southern end of the bore field to over 50 metres (165 ft) at the north. The water table slopes generally to the south with gradients varying locally from 1.5 x 10<sup>-3</sup> to 4.5 x 10<sup>-3</sup>.

## AQUIFER CHARACTERISTICS

Computer print-outs of reduced data from the 48-hour pumping tests are available as log-drawdown versus log-time, drawdown versus log-time, and recovery versus log-time plots on file with the Perth Metropolitan Water Board. The type-A delayed-yield curves (Boulton, 1963) and straight-line methods have been applied to these data plots to derive transmissivity values for each site. Results for each site are given in Table 2. Contours of transmissivity are on Plate 1 and show transmissivity conforming to aquifer thickness.

Detailed analysis of different bore designs on each of sites 210 and 310 using Boulton delayed-yield curves, straight-line time and distance-drawdown, modified recovery, and straight-line time-recovery methods confirmed that design of bore screens and pumping tests had a stronger control on measured transmissivity than did the method of analysis.

In the analysis of data from each site, after checking bore designs and well logs to see if partial penetration, inhomogeneity, or anisotropy were likely to be important, an initial plot of log-drawdown versus log r<sup>2</sup>/t for early and late times on all bores was useful for comparing bore response and direction and degree of divergence from a type curve.

Plate 2 contrasts data plots for a short and a long-screened bore at site 310. Identical non-equilibrium type-curve matches are shown for the two bores. Data plots from the longer screened bore G test conform closely to Boulton type-A curves. Data plots of the shorter screened bore F test at the same site however, show that only the more fully penetrating G bore is responding along the type curves. Other shorter screened bores, including the pumped bore, are drawn down excessively due to the effects of partial penetration and cannot be matched to distance-drawdown curves.

If the distance-drawdown data plots appeared to be scattered a preliminary match was made from the more distant and more fully penetrating bores. Boulton, straight-line, or other analyses were then made according to the assumptions for each method. Straight-line methods were used in some cases when u = r<sup>2</sup>S/4Tt was less than 0.02, as in the earliest time periods before the storage coefficient began increasing due to delayed yield. Recovery data usually plotted more smoothly than drawdown data.

Results among all methods of analysis were more nearly consistent when pumping tests were designed in close agreement with the assumptions made for the non-equilibrium formula. The fractional penetration of pumping and observation bores was important in its effects on results. Short-screened pumping and observation bores with 6 metres (20 ft) of screen in the bottom third of the aquifer showed several undesirable effects of partial

TABLE 2. AVERAGE TRANSMISSIVITY AND PERMEABILITY

Site	Boulton Curves	Jacob Method Time-Drawdown	Jacob Method Time-Recovery	Transmissivity Average of Methods		Permeability (P = T/m)	
	$T = Q \frac{W(u, r/B)}{4\pi s}$	$T = 0.183 Q/\Delta s$	$T = 0.183 Q/\Delta s$	(m <sup>2</sup> /d/m)	(gpd/ft)	(m <sup>2</sup> /d/m <sup>2</sup> )	(gpd/ft <sup>2</sup> )
100	361	497	482	447	30,000	11	220
110	482	452	497	477	32,000	11	220
120	407	437	407	417	28,000	11	220
130	361	632	527	507	34,000	13	270
140	211	271	361	281	19,000	7.4	150
200	617	648	542	602	40,000	12	250
210	256	497	632	462	31,000	9.6	200
220	376	662	647	562	38,000	12	250
230	241	271	286	268	18,000	5.4	110
240	300	271	241	271	18,000	5.3	110
300	482	587	632	567	38,000	11	220
310	858	983	994	936	62,000	18	370
320	798	1,350	1,160	1,100	74,000	22	450
330	677	678	851	735	49,000	14	290
340	407	512	677	532	36,000	11	220

NOTE: 1 m<sup>2</sup>/d/m = 1.491 x 10<sup>-3</sup> gpd/ft  
 1 m<sup>2</sup>/d/m<sup>2</sup> = 4.893 x 10<sup>-3</sup> gpd/ft

penetration. They tended to test a thinner section of aquifer near the pumping bore with resultant lower transmissivity values, smaller specific capacity, excessive drawdown in observation bores, and deviation from a type curve on distance-drawdown plots of observation bore response. The deviation was often greater than that due to partial penetration in a homogeneous aquifer, according to Butler's (1957) tables. Distant observation bores, in some cases, were drawn down more than near observation bores, implying that partial penetration effects were accentuated by aquifer inhomogeneity and anisotropy.

Tests on longer screened bores, however, with about 24 metres (80 ft) of screen in 50 metres (165 ft) of aquifer, generally showed that partial penetration effects were negligible.

The effective early-time storage coefficients derived from Boulton type-A curve matches to field data from the 2-day tests were generally in the artesian range. A time-variable storage coefficient due to delayed yield is expected from bores screened in the lower half of a thick, inhomogeneous, water-table aquifer. Longer pumping periods, of a few days or weeks, would have allowed more nearly complete drainage of delayed yield from sands in the upper part of the aquifer. Plate 2 shows how the storage coefficient at site 310, as calculated by distance-drawdown Theis curve matches, increases toward water table values as the match point value of  $r^2/t$  gets smaller with increasing time. Storage coefficients from longer screened bores would have reached water table values more quickly, probably because of a smaller thickness of saturated sands above the screened interval. An estimated specific yield of 25 per cent is believed to be more useful than the time-variable artesian-range storage coefficient in calculating volumes of water in storage.

Permeability (P) was calculated by dividing transmissivity by the total saturated aquifer thickness (m). Transmissivity and permeability as averaged for each site are given in Table 2.

Contours of transmissivity, permeability, and isopachs of the saturated aquifer are shown in Plate 1. These contours show that part of the northerly increase in transmissivity is due to an increase in aquifer thickness, but there is also a related variation in permeability of the sands.

The permeability and transmissivity variations do not correlate well with changes in thickness of the medium sand, coarse sand, or calcarenite, suggesting that the aquifer is best treated as a single hydrologic unit.

Also shown are isochlors from a map by Bestow (1971). Isochlors, although masked somewhat by the effects of local discharge and recharge, appear to conform to transmissivity contours.

#### BORE CHARACTERISTICS

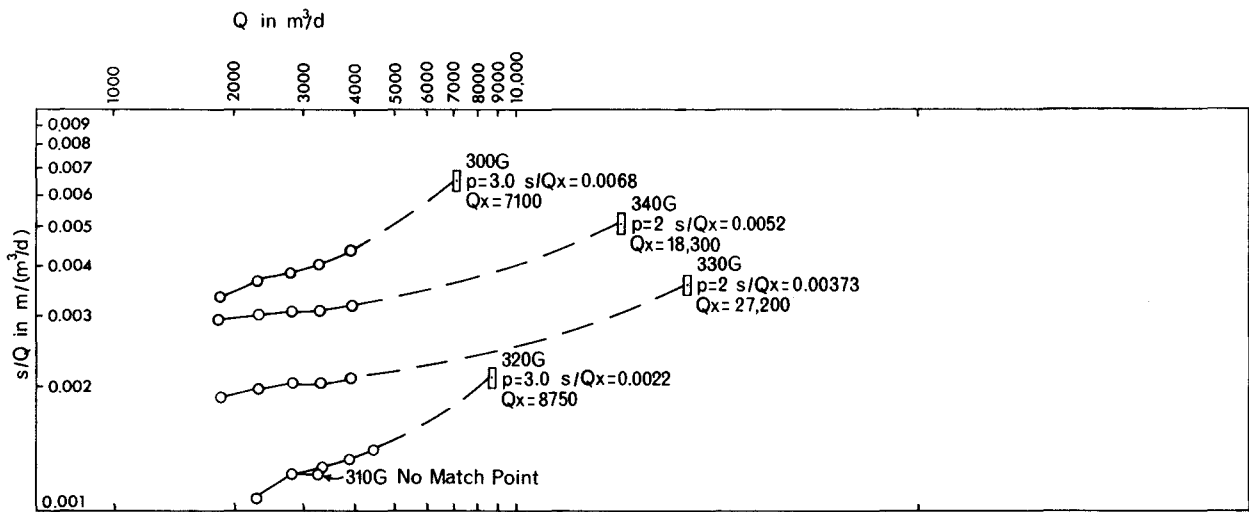
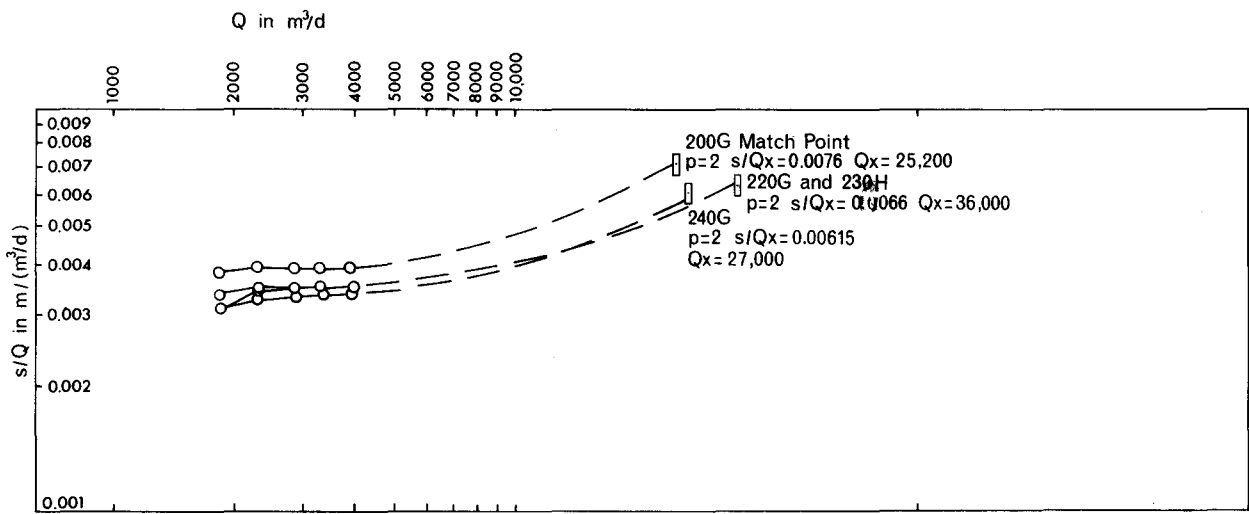
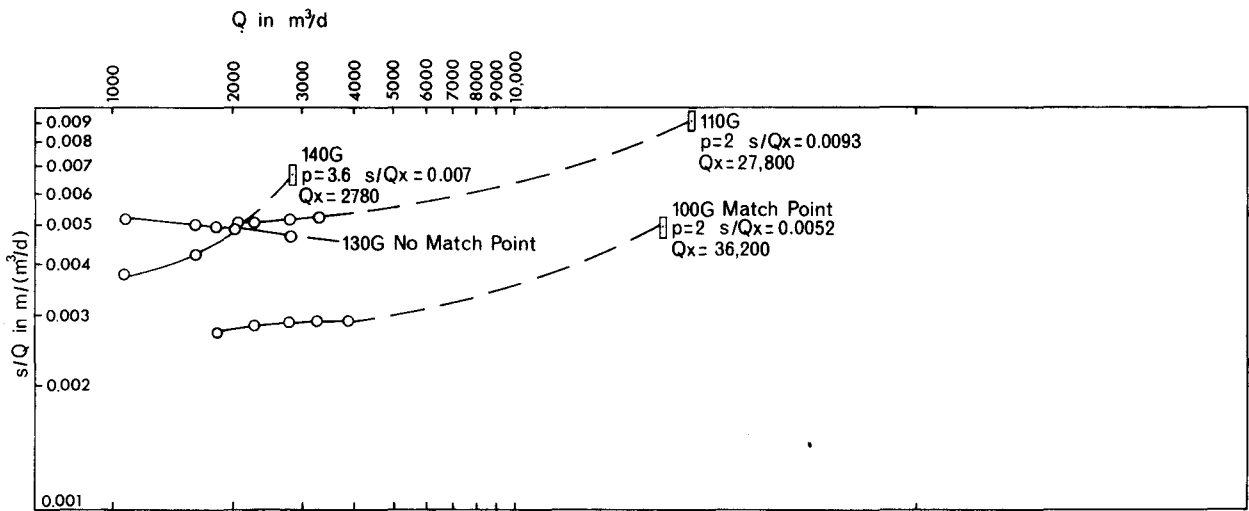
According to Walton (1962), drawdown in a pumping bore may be broken down into several head-loss components:

- $S_a$  = losses due to resistance to horizontal flow in the aquifer;
- $s_p$  = losses due to increased length of flow paths caused by partial penetration of the aquifer;
- $s_d$  = dewatering correction to compensate for reduction of the aquifer thickness;
- $s_r$  = head gained from water added by recharge;
- $s_b$  = losses due to barrier or discharge boundaries;
- $s_w$  = losses due to turbulent flow in or near the bore screen.

These drawdown components can be treated in step-drawdown analyses by grouping all laminar flow losses ( $s_a + s_p + s_r + s_b$ ) which vary linearly with Q, into one term ( $B_s Q$ ) and a turbulent flow-loss term ( $s_w$ ) which varies as some power (p) of Q and is expressed as  $(CQ^p)$ , giving the formula cited by Sheahan (1971) for observed drawdown in a pumping bore:  $s = B_s Q + CQ^p$ .

Step-test data for G and H series bores other than 310 and 210 are plotted in Figure 3 as  $s/Q$  versus Q for use with Sheahan's type curves. Results for  $B_s$ , C, p, and efficiency measured as  $B_s Q/s$  at the tested rate, are given in Table 3. Only one bore is less than 80 per cent efficient by this method at the tested rate and time. Efficiency may increase with time as the  $B_s$  coefficient increases.

Step-test data are not available for bores 210G and 310G, so laminar and turbulent flow-loss coefficients are estimated from knowledge of transmissivity and observed drawdown during the 48-hour pumping test. Laminar flow losses ( $B_s Q$ ) are assumed to be equal to  $S_a + S_p = QW(u)/4\pi TC_{pp}$ . Transmissivity is known from the 2-day pump test,  $C_{pp}$  is a partial penetration constant taken from tables in Butler (1957), and  $W(u)$  can be taken from tables when (u) is calculated as  $r^2 S/4Tt$ . Coefficients  $B_s$  for bores 210G and 310G were calculated in this way and compared with observed drawdown (s) at  $t = 0.01$  day to get their efficiency values given in Table 3.



STEP-TEST DATA PLOTS  
WITH SHEAHAN'S TYPE-CURVE MATCH POINTS

Figure 3.

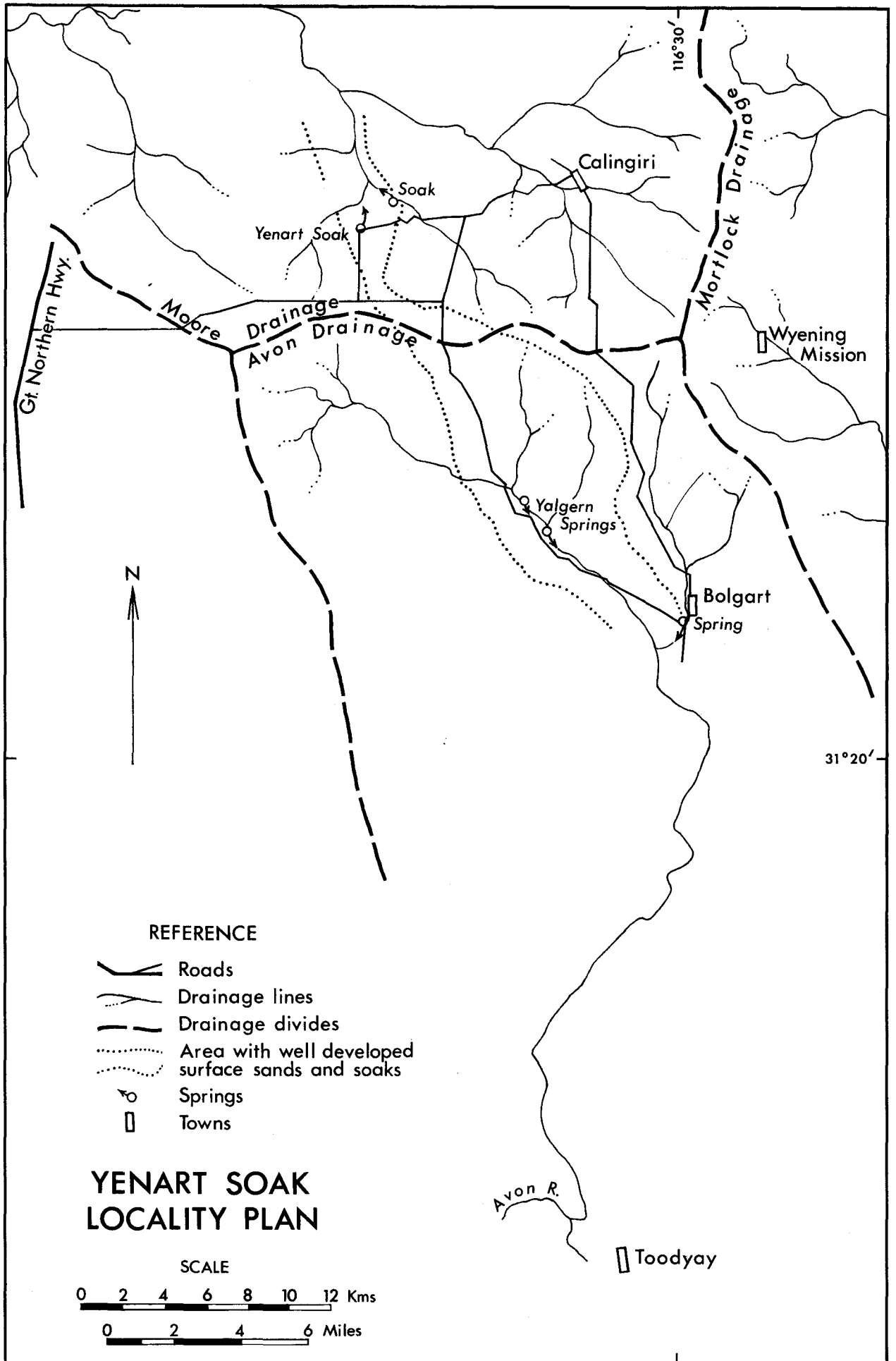


Figure 4.

TABLE 3. RESULTS OF TYPE-CURVE SOLUTION OF STEP-DRAWDOWN TESTS

$s = B_t Q + CQ^p$   
 $B_t$  = Laminar flow-loss coefficient  
 $C$  = Turbulent flow-loss coefficient  
 $t$  = 0.01 day  
 Efficiency =  $B_t Q/s$  (100)

Bore	$B_t$ (m/(m <sup>3</sup> /d))	$C$ (m/(m <sup>3</sup> /d)) <sup>p</sup>	p	Specific capacity ((m <sup>3</sup> /d)/m)	Efficiency at tested pumping rate
100G	$2.61 \times 10^{-3}$	$0.72 \times 10^{-7}$	2	342	89%
110G	$4.66 \times 10^{-3}$	$1.68 \times 10^{-7}$	2	187	87
120G	No step-test data				
130G	No useful match due to development				
140G	$3.49 \times 10^{-3}$	$0.39 \times 10^{-11}$	3.6	194	68
200G	$3.8 \times 10^{-3}$	$1.5 \times 10^{-7}$	2	256	93
210G	No step-test data				
220G	$3.3 \times 10^{-3}$	$9.2 \times 10^{-7}$	2	172	67
230H	$3.3 \times 10^{-3}$	$9.2 \times 10^{-7}$	2	284	90
240G	$3.1 \times 10^{-3}$	$1.15 \times 10^{-7}$	2	243	81
300G	$3.4 \times 10^{-3}$	$0.67 \times 10^{-10}$	3	284	87
310G	No step-test data				
320G	$1.1 \times 10^{-3}$	$0.16 \times 10^{-10}$	3	800	near 10
330G	$1.86 \times 10^{-3}$	$0.68 \times 10^{-7}$	2	775	88
340G	$2.6 \times 10^{-3}$	$1.42 \times 10^{-7}$	2	474	89
				316	82

NOTE:  $1 \text{ m/(m}^3/\text{d)} = \frac{1 \text{ ft/gpm}}{21.5}$   
 $1(\text{m}^3/\text{d})/\text{m} = \frac{1 \text{ gpm/ft}}{4.66 \times 10^{-3}}$

CONCLUSIONS

The results of type-curve analysis of step-drawdown and constant-rate pumping tests at the North Gngangara bore fields show that:

- (1) transmissivities over the bore field vary from 268 m<sup>3</sup>/d/m (18,000 gpd/ft) to 1,100 m<sup>3</sup>/d/m (73,000 gpd/ft). The higher transmissivities are in the northernmost line of bores;

- (2) at the end of 2 days' pumping tests, drawdown was in equilibrium with delayed yield of water in the upper part of the aquifer, and does not reflect the aquifer's long-term storage characteristics. An estimated water table storage value of 0.25 is more useful than the time-variable storage coefficient derived from the Gngangara pumping tests for calculating quantities of water in storage;
- (3) the use of more fully penetrating screens in pumping bores increases the bore's specific capacity and efficiency by reducing head losses caused by the increased length of flow paths to partially penetrating bores;
- (4) in the vicinity of the Gngangara bore field, areas of relatively low chlorinity may indicate areas of relatively high transmissivity.

REFERENCES

Bestow, T. T., 1971, The water balance in the North Gngangara area: West Australia Geol. Survey Ann. Rept. 1970, p. 14-17.  
 Boulton, N. S., 1963, Analysis of data from non-equilibrium pumping tests allowing for delayed yield from storage: Inst. Civil Engineers, London, Proc. v. 26, p. 469-482.  
 Butler, S. S., 1957, Engineering hydrology: Prentice-Hall, Englewood Cliffs, N. J.  
 Sheahan, N. T., 1971, Type-curve solution of step-drawdown test: Ground Water, 9, no. 1, p. 25-29.  
 Walton, W. C., 1962, Selected analytical methods for well and aquifer evaluation: Illinois State Water Survey, Bull. 49, 81p.

SATURATED SANDS AT YENART SOAK

by P. Balleau

ABSTRACT

Near Calingiri an accumulation of residual sands contains at least  $4.1 \times 10^6$  cubic metres (90 x 10<sup>6</sup> gal) of potable water. An estimated 1.45 x 10<sup>6</sup> cubic metres (3.2 x 10<sup>6</sup> gal) per year could be converted to pumpage with a negligible net change in storage. A proposed 30.5-centimetre (1 ft) diameter production bore screened from 0.9 to 2.8 metres (3 to 9 ft) below the water table and near the centre of the sand body will allow a pumping rate tentatively in excess of 2.28 litres per second (1,800 gph) without contamination from deeper saline water.

Other saturated residual-sand reservoirs are likely to be present near permanent soaks along the upper Mortlock, Avon, and Moore drainage basins.

INTRODUCTION

Saturated sands at Yenart Soak, 11 kilometres (7 miles) west of Calingiri, were sampled by augering during April to June, 1971.

The soak is 65 kilometres (40 miles) north of Toodyay (Fig. 4) near the drainage divides separating the Moore River, Mortlock River, and Yulgan Brook (which reaches the Avon River at Toodyay). The peaks of the divides represent an old surface continuous with that of the sandplain country east of the Meckering line (Mulcahy, 1967). Air-photographs show surface sands draping the drainage basin slopes and containing numerous seeps or ponds, especially west of Wyening.

A generalized geological section shows a basement of granites, gneisses, schists, quartzite, phyllites, talc and other rock types intruded by

mafic (doleritic) and felsic dykes and quartz veins. On these rocks a weathering profile is developed, often consisting of several metres of sandy kaolinitic clay, capped by laterite.

According to Jutson (1934) many drainage divides in this area were established before capture, during the Pleistocene, of the drainages by the Swan-Avon or Moore River systems. The oldest weathering profile of the basement rocks may therefore be assumed to have developed on pre-Pleistocene surfaces.

The Calingiri area is in Mulcahy's zone of younger laterite, characterized by laterites developed on stable slopes eroded into the older peneplain. The zone of younger laterites is not affected by the rejuvenated valleys such as occur at Toodyay.

The surface around a pumped sump on the drainage divide near Wyening contains well rounded, weathered, quartz and quartzite gravel and cobbles, cemented in laterite or weathered free in the surface sand and silt. They were observed in sands more than a kilometre wide along the Calingiri-Bolgart road. Such gravel may represent deposits of pre-Pleistocene drainages in the Darling peneplain, or perhaps residuals from weathering of a metaconglomerate. Their relatively wide extent and location near the oldest topographic surface suggests that sedimentary deposits, incised in the old Darling peneplain, are preserved as remnants in the area. Their origin cannot be clarified without more detailed mapping.

## YENART AUGER-HOLE FIELD

In the search for a township water supply for Calingiri, Whincup (1968) proposed exploratory auger holes in shallow sands at several places including Yenart Soak, where there was surface evidence of shallow fresh water. Some 80 auger holes were bored at Yenart on an irregular grid pattern, about 600 metres (2,000 ft) on a side, covering the hill slope above the soak. The shape of the sand body and the fresh water lens are shown in Figure 5. More detailed logs of each hole are on file with the Public Works Department.

The Yenart Sands are thought to be residual-colluvial beds resulting from in-place weathering of a quartzose crystalline rock, with hydrolysis of readily weathering minerals and their removal as ions in groundwater. Analysis of the size, shape, and mineralogy of the grains, and of the shape, position and structure of the sand body, indicates that the sands have not been transported.

Auger-hole samples range from coarse to very fine, poorly sorted, sand and even clay. One sample, from just above the bedrock, had a clay fraction by weight of 37.5 per cent, which probably represents a clay filling of the pore volume of the quartz sand. Sorting indices ( $S_s = \sqrt{75}$  per cent pass size/25 per cent pass size) range from 2.1 to 3.6 in the range of values for a residual sand derived from granite (Pettijohn, 1957). Both fine and coarse fractions consist of angular quartz grains, sometimes with a slightly knobby or solution-pitted surface.

No difference could be seen in ranges of grain size, texture, or mineralogy between sand in the underlying clayey matrix and the cleaner sands above.

The clean sands show some colour zoning, typically, from the surface: a brown soil a few centimetres thick, underlain by a yellow or brown pisolitic laterite 1 to 3 metres (3 to 10 ft) thick, then clean white sands 1 to 13 metres (3 to 40 ft) thick, then increasingly red iron-stained sands down to the clayey sands which generally overlie the bedrock.

Texture and maturity also suggest that the sands are residual in origin, as they agree with Twenhofel's four criteria for identifying residual sands i.e., poorly sorted, irregularly shaped grains, coated with iron oxide, and perhaps solution pitted.

The shape and position of the sand bed are shown in Figure 5. The long axis trends generally in a north-south direction, and is probably continuous with sands in an auger hole 1 kilometre (0.6 miles) south of the soak. The present surface drainage area above this soak is small (0.63 square kilometres or 0.244 miles<sup>2</sup>) and the sands, which extend beyond the surface drainage area, are apparently unrelated genetically to the present drainage, or to the laterite on the sands in high areas.

As near as can be measured in auger holes, the lens of fresh water has a flat upper surface. Its irregular bottom surface rests on: (1) clay or rock on the upslope (west) side; (2) saline water rising from below towards the soak; and (3) bedrock of varying level as between holes F1 and FO (Fig. 5). Several 30-metre (100 ft) auger holes (between K10 and F10) failed to penetrate the full thickness of the fresh water.

Mulcahy has described yellow sand-filled depressions, similar to colluvial sand deposits of the sand-plain country west of the Meckering line, in old plateau remnants along the south branch of the Mortlock River west of York. When cut by advancing erosional fronts, such depressions (spillways) spill sand collected from adjacent surfaces through the erosional break, and often act as collectors and reservoirs for permanent supplies of fresh water in soaks. The sands at Yenart Soak appear to differ in origin from such sand-filled depressions primarily in containing residual white and iron-stained red sands rather than yellow sands derived from weathered laterite, demonstrating less transport ( $S_s$  between 2.1 and 3.6 as against 1.4 and 2.0 for spillways), and showing less vertical zonation such as multiple laterites.

The unusual thickness of angular, poorly sorted, white and red quartz sands developed under a laterite cap and overlying kaolinite clays and sands of the typical granite weathering profile at Yenart Soak, are probably best described genetically as residual-colluvial sands developed over a readily weathering quartzose crystalline rock. The sands act as a reservoir for fresh water which infiltrates throughout the outcrop and is discharged as soaks downslope. Water salinity is probably a function of the time water is in contact with the weathering zones. Salinity increases with depth because fresh water from rainfall infiltration is added to the upper surface of the water table, where permeabilities and flow velocities are greater. Both saline and fresh water are discharged to the soak, where the salinity is rapidly increased by evapotranspiration processes. It may be expected that flow through the beds removes some weathering products as ions in the discharging water.

## TENTATIVE YIELD ANALYSIS

Two important limits on production from the fresh water lens at Yenart are: (1) the maximum perennial withdrawal and (2) the maximum hourly production from an individual well that will not cause movement of poorer quality water into the well. For a tentative calculation, assume that 5 per cent of the average 46-centimetre (18 in) annual rainfall falling on the intake area (0.63 square kilometres or 0.244 miles<sup>2</sup>) is available as recharge to the fresh water lens, the area of which is defined by the auger-hole field (0.248 square kilometres or 0.095 miles<sup>2</sup>) and that the specific yield of the sands is 25 per cent. In fact the groundwater divides are not coincident with surface water divides and the reservoir surface may extend well outside the auger-hole field.

The volume of water in storage has been calculated from the cross sections. The saturated fresh water sands occupy  $1.66 \times 10^6$  cubic metres ( $5.85 \times 10^7$  ft<sup>3</sup>) which, if the sands have a specific yield of 25 per cent, contain  $4.1 \times 10^5$  cubic metres ( $91 \times 10^6$  gal) of water of less than 1,000 ppm.

By making use of the basic hydrologic equation: Inflow = Outflow + Change in Storage we can estimate an outflow (pumpage) which would balance estimated inflow from rainfall infiltration and result in negligible net annual change in storage.

Such a calculation assumes that all present outflow is through the soak, with no other outlet.

At 5 per cent of the rainfall, the estimated annual recharge reaching the water table expressed as an annual inflow is 2.3 centimetres per year per 0.63 square kilometres =  $1.43 \times 10^4$  cubic metres ( $3.18 \times 10^6$  gal) = inflow. Pumpage of about  $1.43 \times 10^4$  cubic metres ( $3.2 \times 10^6$  gal) per year would be expected to stop the natural outflow of the soak and deplete storage during dry months, with replenishment during winter. Pumpage of  $1.43 \times 10^4$  cubic metres ( $3.2 \times 10^6$  gal) per year is a tentative value which could be subject to adjustment after observing the behaviour of the water table through a yearly cycle.

Site development should include enough observation bores to determine the slope of the water table, daily changes in the water table, and its reaction to pump tests and production. Information on transmissivity, permeability, storage coefficient, locus of boundaries, area of the reservoir, changes in storage, and better definition of the yield of the aquifer could then be calculated. Observation bores should be at: (1) the auger-hole location 1 kilometre (0.6 miles) south of Yenart to determine the areal extent and hydraulic continuity of the lens; (2) at distance (r) from production bore of 305 metres (1,000 ft) near Q10, at r approximately 280 metres (900 ft) near N16, and at r approximately 210 metres (700 ft) near G2, to determine the slope of the water table; (3) at r approximately 60 metres (200 ft) near F7 and r approximately 15 metres (50 ft) for pump-test data; and (4) at r less than 1 metre (3 ft), perforated to 18 metres (60 ft) below the water table, for observing development of the saline cone below the pumping bore.

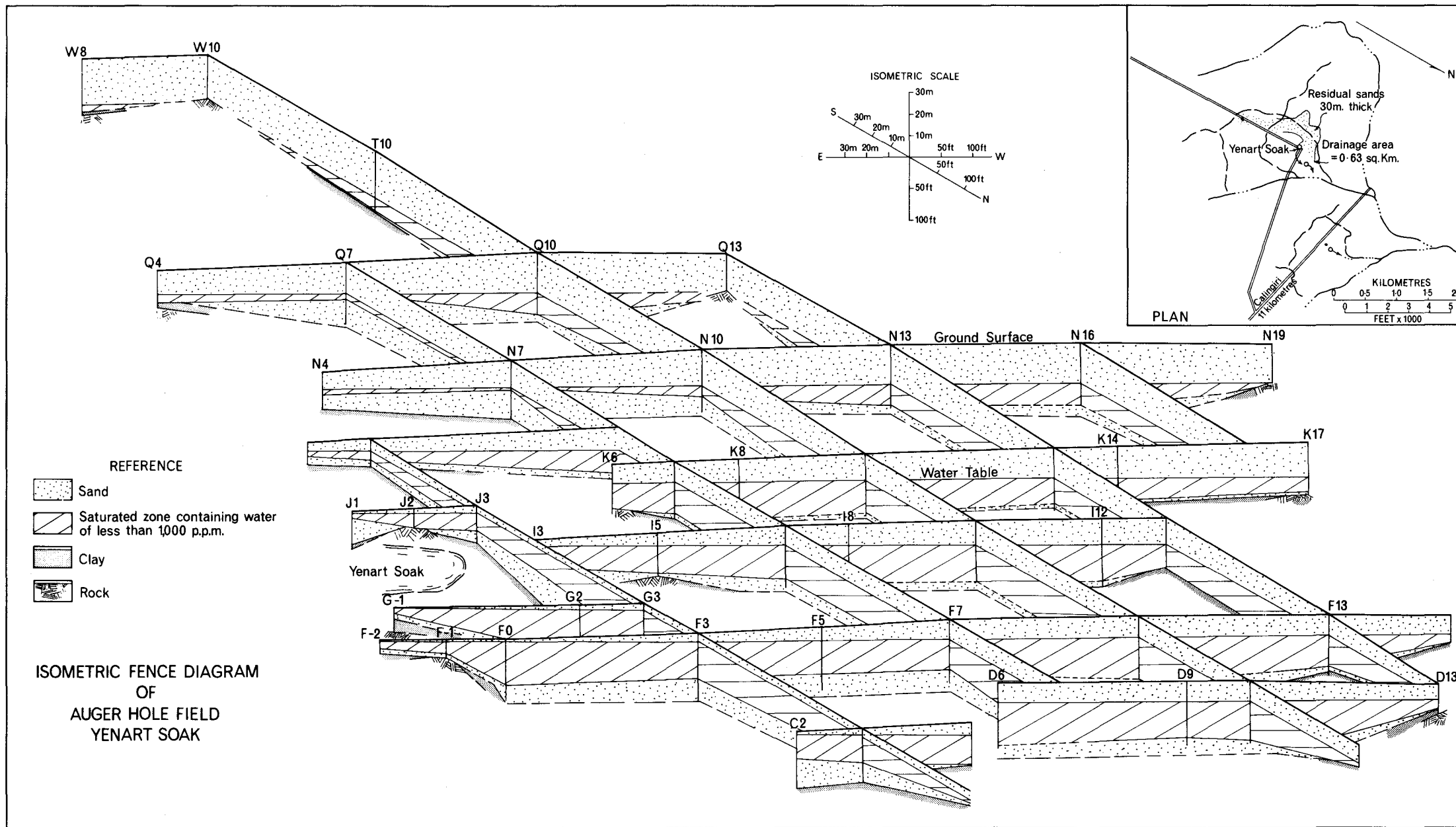


Figure 5.

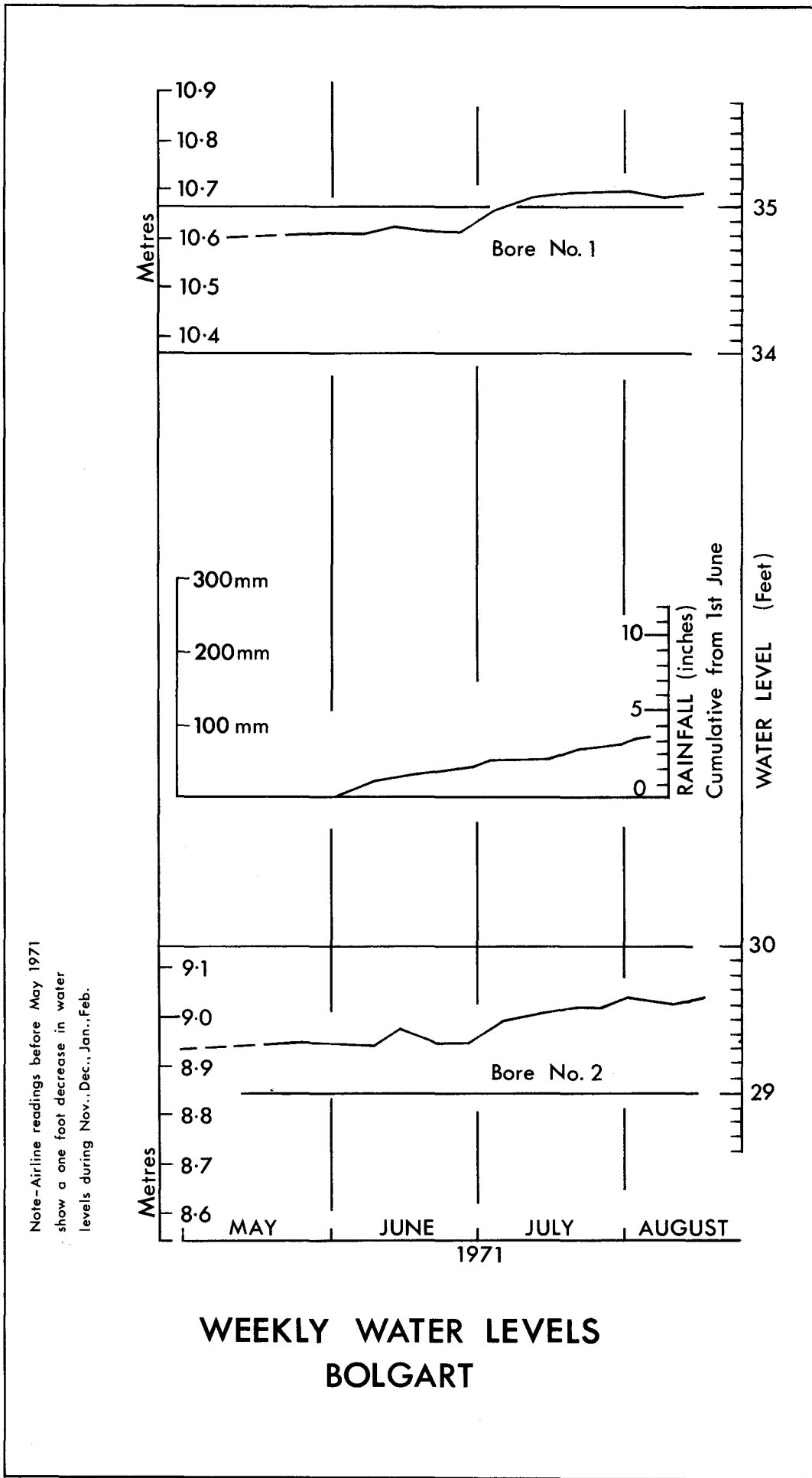


Figure 6.



The behaviour of the 1,000 ppm fresh/salt interface is important in determining pumping rates and bore design. Bennett and Mundorff (1968) have provided criteria for designing bore fields which pump fresh water under equilibrium conditions, and develop stable cones of salt water under the pumping bore. Taking the thickness of fresh water as 18 metres (60 ft), the maximum abstraction of fresh water can be obtained at G9 by placing the bore screen between the levels of 0.9 and 2.8 metres (3 and 9 ft) below the water table. The pumping rate cannot be accurately calculated without knowing the permeability of the sands, but an estimate can be based on transmissivity results (T approximately 222 m<sup>3</sup>/d/m (14,700 gpd/ft)) of a pumping test in similar sands at Bolgart.

Using the non-equilibrium formula, neglecting boundaries, and assuming 12-hour pumping periods with 12-hour recovery from a 30.5-centimetre (1 ft) diameter screen with a maximum drawdown of 0.9 metres (3 ft) in an aquifer of transmissivity 240 m<sup>3</sup>/d/m (16,000 gpd/ft):

$$u = r^2 S / T t^4$$

$$= (0.305)^2 \cdot 2.5 \times 10^{-1} / 4 \cdot (2.4 \times 10^3)^2 \cdot 0.5$$

$$= 4.9 \times 10^{-4}$$

therefore W(u) from tables = 7.04

$$Q = 4 \pi T s / W(u)$$

$$= 2.4 \times 10^2 \cdot (0.9) \cdot 12.6 / 7.04$$

$$= 3.7 \times 10^2 \text{ m}^3/\text{d} = 4.28 \text{ l/sec} = 3,400 \text{ gph.}$$

For comparison, 24-hour per day pumping at the rate of 2.22 litres per second (1,850 gph) for a year would produce approximately the same volume of water and the same drawdown.

A bore of such design would have an estimated production capacity considerably in excess of the expected available annual recharge. Pumping hours could be adjusted to accommodate the effects of factors such as intermittent pumping, increased drawdown due to the effect of boundaries, unknown permeability, increased well diameter or increased allowable drawdown (perhaps 1.5 metres (5 ft) instead of 0.9 metres (3 ft)). Such an increase in allowable drawdown may be desirable to allow for boundary effects.

The present annual flow through the aquifer, estimated at 1.45 x 10<sup>4</sup> cubic metres (3.2 x 10<sup>6</sup> gal), if added to, or removed from the reservoir area of approximately 0.25 square kilometres (0.096 miles<sup>2</sup>) without other recharge or discharge, would represent a change in water level of only 0.25 metres (0.83 ft) for a specific yield of 0.25. This figure is near the annual fluctuation in water level to be expected if the aquifer were pumped at 1.45 x 10<sup>4</sup> cubic metres (3.2 x 10<sup>6</sup> gal) per year. Water levels in the similar sands at Bolgart fluctuate about 30 centimetres (1 ft) through the year.

The most important limit on production at Yenart is the maximum perennial withdrawal rather than the maximum hourly production of good quality water from an individual well. Data to be gathered from the proposed observation bores will help to determine the true value for maximum perennial withdrawal.

#### SOME OTHER SOAKS IN THE AREA

As an extension of the Yenart drilling, an auger hole was drilled about 90 metres (300 ft) upslope from a soak on Location 2593, 1.5 kilometres (0.9 miles) northeast of Yenart Soak where a 4.6-metre

(15 ft) thickness of water of less than 1,000 ppm was found. The site showed on air-photographs as a white sand-covered slope above a reedy soak. When there is no other outflow, the volume of discharge from soaks is a function of the volume of reservoir, and this smaller soak is not expected to be fed by as large a volume of saturated sands as Yenart. However, information from this auger hole appears to confirm the relation of soak, sands, and fresh water lens, which might aid in finding other sites for exploratory drilling.

Examination of air-photographs shows that soaks and ponds are relatively common throughout the white sand area shown on Figure 4. Yalgern Springs, 8 kilometres (5 miles) northwest of Bolgart, exemplify the type of reedy soak with a good flow but little drainage area above it, that might be expected to be fed by residual sands similar to those at Yenart.

Bolgart township water supply is in a similar sand body. It has been developed for production since 1961, and further auger-hole drilling was done in 1970 to determine the shape of the sand body and the fresh water lens. The sands are probably similar in origin to those at Yenart, being a north to northwest-trending unit, not conformable with present topography, in places over 30 metres (100 ft) thick, with a water table which slopes toward a spring beside Bolgart Brook. The 1,000 ppm interface rises, as the result of flow of water toward a soak. The water table fluctuates seasonally about 30 centimetres (1 ft) during the year, and responds quickly to rainfall (Fig. 6). A pumping test over a vertical interval of 6.1 metres (20 ft) in the bore gave a transmissivity value of 222 m<sup>3</sup>/d/m (14,700 gpd/ft) and a storage coefficient of 0.049, which may indicate delayed yield conditions with a long-term storage coefficient closer to 0.25.

Other sources of fresh water in saturated residual sands might be found in the zone of younger laterites along the Mortlock River, Toodyay Brook, or the east branch of the Moore River, by examining air-photographs for permanent soaks lying in white sand areas between the old plateau remnants, and having a disproportionately small surface drainage area above them.

#### REFERENCES

- Bennett, G. D., Mundorff, M. J., and Amjad Hussain, S., 1968, Electric analog studies of brine coning beneath fresh water wells in the Punjab Region, West Pakistan: U.S. Geol. Survey, Water Supply Paper 1608-J, 31 p.
- Jutson, J. T., 1934, The physiography of Western Australia: West. Australia Geol. Survey Bull. 95.
- Mulcahy, M. J., 1967, Landscapes, laterites, and soils in southwestern Australia, in Landform studies from Australia and New Guinea: Australian National University Press, Canberra, p. 211-230.
- Pettijohn, F. J., 1957, Sedimentary rocks: Harper and Brothers, New York, 718 p.
- Twenhofel, W. H., 1932, Treatise on sedimentation: Bailliere, Tindall and Co., 890 p.
- Whincup, P., 1968, West. Australia Geol. Survey Hydrogeological Rept. no. 606 (unpublished).

# GROUNDWATER RESOURCES ALONG THE LOWER GASCOYNE RIVER— A SUMMARY

by A. D. Allen

## ABSTRACT

The usable groundwater resources associated with the lower Gascoyne River are restricted to the river-bed sand, which forms the bed load of the river, and the immediately adjacent silty flood-plain deposits. The river-bed sand between 9.7 and 79 kilometres (6 and 49 miles) above the river mouth is reliably estimated to contain 20 million cubic metres (16,260 acre ft) of groundwater immediately after a river flow, and the flood-plain deposits about 152 million cubic metres (123,000 acre ft) of water suitable for irrigation or domestic supply. The groundwater resources in the river-bed sand are the most easily exploitable and of the best quality available (300 to 600 ppm TDS). However, they are substantially depleted by transpiration, evaporation and infiltration (in order of importance). These losses are slightly offset by replenishment from rainfall and local runoff. Quantitative estimates of these components are given.

Correct location and design of abstraction wells will be needed to enable full exploitation of the renewable resources in the river-bed sand. By comparison, groundwater resources in the nearby flood-plain deposits are of variable quality and may have unacceptable levels of boron and fluoride. However, they form the largest available volume of usable groundwater, and as such should be developed despite difficulties of bore siting and abstraction. The establishment of pumping bores in the flood-plain deposits would provide an insurance against the failure of more easily exploitable sources. Because the deeper groundwater is probably replenished at a relatively low rate and there is a risk that over-abstraction will cause the ingress of saline water, strict overall groundwater management is considered essential.

## INTRODUCTION

### GENERAL

The lower Gascoyne River, for the purpose of this report, extends across the coastal plain from Kennedy Range westwards to the sea, a distance of about 145 kilometres (90 miles). Carnarvon is situated at the mouth of the river (Fig. 7) and is about 970 kilometres (600 miles) by road north of Perth. Its population was 5,750 in 1969 and is increasing rapidly. The principal industry is the growing of fruit and vegetables in irrigated plantations and gardens situated on the river banks along the lower 19 kilometres (12 miles) of the river.

### CLIMATE

The mean annual rainfall at Carnarvon is about 216 millimetres (8.5 in) (Fig. 7). It mainly comes from cyclones and thunderstorms in summer and from occasional rain-bearing depressions in winter. As a consequence, rainfall may vary widely from year to year.

The warmest month is February and the coolest month July, with mean maxima of 31.2° and 22.1°C (88.1° and 71.7°F) and minima of 22.1° and 10.9°C (71.7° and 51.6°F) respectively. The average annual evaporation is about 2,140 millimetres (84.3 in) which exceeds the rainfall by about ten times.

### RIVER REGIME

Although the Gascoyne River is the second largest in the State, with a catchment area of 79,000 kilometres<sup>2</sup> (30,500 miles<sup>2</sup>), flows are intermittent and water quality is variable. Over the last 65 years the river has flowed on an average of 1.5 times per year, but once every 5 to 6 years fails to flow, the longest period without river flow being 3 years. The usual duration of river flows is about 2 to 4 months and estimates of the average annual discharge range between 494 and 864 million cubic metres (400,000 and 700,000 acre ft). However, discharges may exceed 3,700 million cubic metres (3 million acre ft) during major floods.

Possible dam sites occur at Rocky Pool and Kennedy Range (Fig. 7), but the high evaporation rate, and the variability in water quality and frequency of flows introduce problems of management, in addition to the technical and economic disadvantages of the dam sites. The site at Kennedy Range has been proved unsuitable while the site at Rocky Pool is at present under investigation.

A small quantity of water for irrigation is obtained directly from the river during flows, but most of the requirements for the town water supply and the irrigation demand are met from groundwater sources.

In 1969 the total abstraction by all users was 932 million cubic metres (7,555 acre ft). About half of this amount is drawn from each of two aquifer systems:

- (1) coarse river-bed sands within the main channel of the river;
- (2) thin irregular beds of sand or silty sand in flood-plain deposits which have a relatively poor permeability.

Experience has shown that the amount of groundwater available in the river-bed sand adjacent to the plantations is limited and is virtually exhausted 6 to 9 months after a river flow. Thereafter supplies are obtained, where possible, from the flood-plain deposits, until such time as a new river flow occurs.

Despite the imposition of legal controls, the amount of groundwater abstraction has been increasing at 15 to 20 per cent per annum since 1966. There has also been a tendency for groundwater from aquifers in the flood-plain deposits to increase in salinity because of the lateral ingress of brackish water.

The present study has been made in order to more completely define the groundwater resources. It is hoped that this, together with a contemporaneous dam site investigation, will provide a scheme for assured water resources.

### PREVIOUS WORK

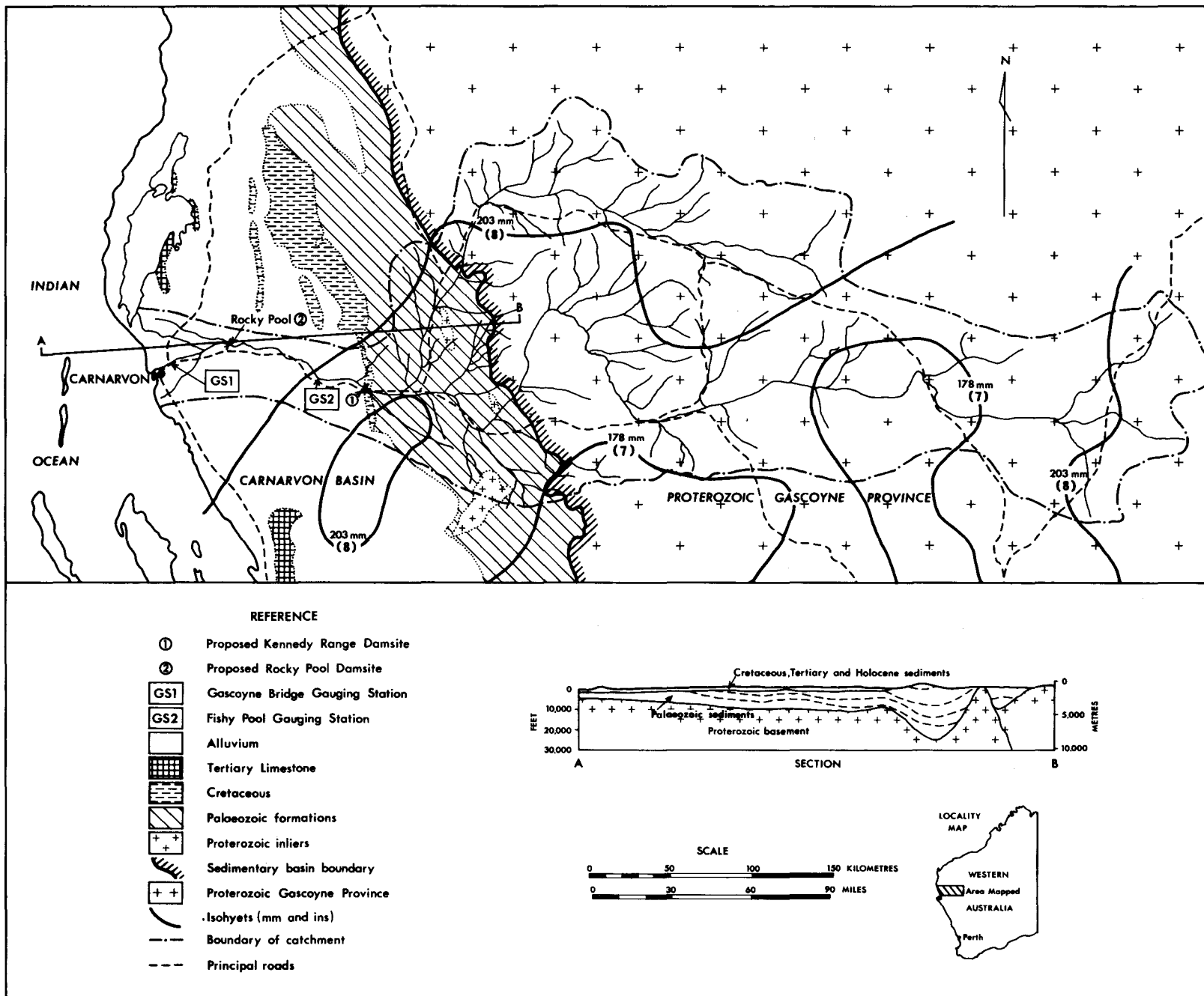
Several projects have been undertaken to obtain assured supplies of groundwater. Three programmes of drilling were conducted between 1935 and 1955 in both the river-bed sand and the flood-plain deposits in the reach between 11.3 and 16 kilometres (7 and 10 miles) above river mouth (A.R.M.)\* without very much success. In 1956, a subsurface clay barrier was constructed across the river in the river-bed sand in order to increase the groundwater storage immediately upstream. This produced a limited improvement but was very localized in effect. Part of the barrier was scoured out in 1957, thus reducing the available subsurface storage (Ellis, 1958).

Since 1959 the Public Works Department has been systematically exploring the river-bed sand section between 16.4 and 32.2 kilometres (10 and 20 miles A.R.M.) by auger drilling on a 101-metre (5 ch) grid. This met with moderate success and resulted in the construction of the "Pilot Scheme" in 1963. This supplies about 5 per cent of the irrigation requirements to some plantations on the south bank. It is to be extended to supply part of the north bank and supplement the town water supply.

A preliminary appraisal of the present area was made by Baxter (1967). This was followed by an auger-drilling programme to qualitatively assess whether losses by vertical infiltration, or lateral underflow along overflow channels, would take place if controlled discharges were released down the river from a dam (Passmore, 1968).

Various artificial groundwater recharge schemes have been proposed for the Gascoyne, but none so far has proved practicable. One example of these

NOTE: \* All bore distances are measured from the river mouth. In P.W.D. notation, P.B. 36/3000 (58.85 km) means percussion bore, 36 miles 3,000 feet (58.85 km) upstream.



12884

Figure 7. Location plan showing catchment, generalized geology and isohyets.

was bore injection which was tested in the "Pilot Scheme" but it was found that the aquifer characteristics permitted only a low rate of acceptance of the recharge water.

**OBJECTIVES AND METHODS OF INVESTIGATION**

The present investigation has followed the general guidelines recommended by a firm of consulting engineers engaged by the Public Works Department to study the Gascoyne area in 1969 (Gibb, 1969). Although conjunctive use of surface and underground water was suggested as a possible future means of meeting the rising demand for water, priority was given to groundwater investigation and development because of the need for an urgent solution. The scope of this work has been enlarged to collate and synthesize the data from previous investigations, and voluminous on-file reports and observations.

The field work was related to three distinct but related aquifer systems:

- (1) river-bed sands;
- (2) flood-plain deposits;
- (3) Cretaceous sediments.

*River-bed sands*

The main objective of this aspect of the work was to determine the volume of sand below the river cease-to-flow level that is potentially available for groundwater storage, and its hydraulic characteristics. Another objective was to establish piezometers for groundwater hydrographic records.

Cross sections were set out at intervals of about 6.4 kilometres (4 miles) in the reach between 3.2 and 33.8 kilometres (2 and 21 miles) where closely spaced bore data were already available from previous investigations, and at intervals of 1.6 kilometres (1 mile) farther upstream to 78.9 kilometres

(49 miles) (Plate 3). Bores were drilled on each cross section at a separation of 91.4 metres (300 ft) to an average depth of 11.3 metres (37 ft) with auger drills. Each bore was drilled through the river-bed sands to the underlying flood-plain deposits, and disturbed samples taken every 1.5 metres (5 ft). Cores were cut from the flood-plain alluvium where this was possible. Water samples were collected in the course of drilling where conditions allowed and also after completion. Each bore was left for observation with slotted P.V.C. tubing in place and with suitable protection against flood damage. A total of 326 bores with an aggregate drilling depth of 3,726 metres (12,225 ft) was drilled.

*Flood-plain deposits*

Twelve bores ranging in depth from 54.9 to 110.3 metres (180 to 361 ft) were drilled by cable-tool methods to test the thickness, water quality and yield of aquifers in the flood-plain deposits. The bores were spaced about 6.4 kilometres (4 miles) apart, extending from the Gascoyne River Bridge to Rocky Pool, and 3.2 kilometres (2 miles) apart upstream from Rocky Pool to the 78.9-kilometre (49 mile) cross section. With the exception of bore 36/4000 (59.16 km), all bores were drilled on the cross sections at points where sampling indicated the water quality to be best (Plate 3). The bores were intended to be drilled only into the top of the underlying Cretaceous and Cainozoic rocks but in some cases they penetrated some distance into these rocks and thereby provided useful stratigraphic information (Allen, 1972). Sludge and water samples were taken at 3-metre (10 ft) intervals. Where aquifers were encountered, pumping tests were carried out using as observation bores the existing bores on the cross sections. A summary of the drilling results is given in Table 1.

TABLE 1. SUMMARY OF PERCUSSION DRILLING RESULTS

Name	Distance above river mouth km	Com-menced	Com-pleted	R.L. m(ft)	Depth m(ft)	Aquifers tested m(ft)	Rate m <sup>3</sup> /day (gph)	Draw-down m(ft)	Salinity ppm TDS	Remarks
<b>OLDER ALLUVIUM TESTS</b>										
Gascoyne River PB 10/310	16.19	20/1/71	28/1/71	7.501 (24.63)	66.1 (217)	Not tested	....	....	....	No significant aquifers
Gascoyne River PB 14/940	22.82	3/3/71	23/3/71	14.539 (47.70)	70.4 (231)	Not tested	....	....	....	No significant aquifers
Gascoyne River PB 18/320	29.07	6/2/71	2/3/71	22.793 (74.78)	110.3 (361)	Not tested	....	....	....	No significant aquifers
Gascoyne River PB 22/720	35.62	1/4/71	16/4/71	23.308 (76.47)	72.2 (236)	Not tested	....	....	....	No significant aquifers
Gascoyne River PB 26/1250	42.41	5/7/71	17/7/71	27.68 (90.82)	77.1 (253)	....	....	....	....	No significant aquifers
Gascoyne River PB 34/1770	55.26	20/4/71	2/6/71	36.075 (118.36)	86.6 (284)	25.3-28.3 (83-93)	873 (8,000)	16.8 (55)	....	Test interval screened
						46.3-49.7 (152-163)	982 (9,000)	23.8 (78)	....	Test interval screened; test stopped because of bore collapse
Gascoyne River PB 36/4000	59.16	7/12/70	22/12/70	38.478 (126.24)	73.2 (240)	33.5-57.9 (110-190)	1,331 (12,200)	12.5 (41)	800	Test from open hole. Sand in TC may have provided significant water
Gascoyne River PB 38/4100	62.41	27/8/70	1/10/70	43.279 (141.99)	99.1 (325)	17.4-20.4 (57-67)	938 (8,600)	3.4 (11)	260	Test interval screened. Aquifer flood-plain deposits (2nd test)
						65.2-79.2 (214-260)	507 (4,650)	20.5 (67)	320	Test from open hole. Aquifer weathered Toolonga Calciflutite (1st test)
Gascoyne River PB 41/100	66.01	2/10/70	7/10/70	48.152 (157.98)	67.1 (220)	Not tested	....	....	....	No significant aquifers
Gascoyne River PB 42/4050	68.83	19/10/70	3/11/70	46.323 (151.98)	61.0 (200)	33.8-61.0 (111-200)	218 (2,000)	n.a.	660	Test abandoned after 5 hours
Gascoyne River PB 45/2150	73.08	19/11/70	3/12/70	50.072 (164.68)	54.9 (180)	24.4-27.4 (80-90)	1,209 (12,000)	14.0 (46)	370	Test interval screened
Gascoyne River PB 48/3750	78.39	6/11/70	16/11/70	55.696 (182.73)	56.4 (185)	250-c50.0 (82-c164)	439 (4,020)	16.2 (53)	480	Test from open hole
Gascoyne River No. 1 (Mooka)	137	15/4/70	22/7/70	c103.63 (c340)	184.4 (605)	Not tested	....	....	....	Apparent large untested supplies 1,480 ppm TDS in Birdrong Formation
Gascoyne River No. 2 (Fishy Pool)	119	27/7/70	16/8/70	93.372 (306.34)	91.4 (300)	Not tested	....	....	....	No significant aquifers

Note: In P.W.D. notation 16.19 (10/310) means 16.19 km (10 miles 310 feet) above river mouth

### Cretaceous sediments

Two bores were drilled to depths of 184.4 metres (605 ft) and 91.4 metres (300 ft) respectively (Plate 3) to test the aquifer potential of the Cretaceous sediments underlying the flood-plain deposits. The main target was the Birdrong Formation, an artesian aquifer known elsewhere to contain brackish or saline water. It was hoped that better quality water would be encountered, as the sites selected were closer to inferred recharge areas. The deeper bore, GR No. 1, was gamma-ray logged and suitable samples from both bores were collected for palaeontological examination.

### GEOLOGY

The lower Gascoyne River crosses the Gascoyne sub-basin of the Carnarvon sedimentary basin (Condon, 1968), of which the geology is shown on published maps (Condon, 1962, 1968). The basin contains as much as 9,140 metres (30,000 ft) of Palaeozoic sediments resting on a crystalline basement.

The Palaeozoic rocks have been folded and faulted and are unconformably overlain by about 457 metres (1,500 ft) of Mesozoic sediments. These dip gently westward and have been faulted and show evidence of local folding (Allen, 1972). Unconformably overlying is a sequence up to 61 metres (200 ft) thick of Cainozoic rocks which extend westward from about Rocky Pool. These, together with the Mesozoic rocks are overlain by an extensive westward-thickening wedge of flood-plain deposits which form the uppermost deposits. The flood-plain deposits reach a thickness of up to 57.9 metres (190 ft) and overlie a distinctive horizon of weathering and lateritization. They are inferred to be of Pliocene-Pleistocene age.

The present Gascoyne River, about 0.8 kilometres (0.5 mile) wide, is incised into the flood-plain deposits and locally exposes Cretaceous rocks as at Rocky Pool and east of Fishy Pool. Between the incised banks of the river there are up to 12 metres (40 ft) of coarse sand forming the bed load of the river.

The stratigraphic section encountered during drilling is shown in Table 2.

TABLE 2. STRATIGRAPHIC SEQUENCE WITH SUMMARY OF LITHOLOGY AND HYDROGEOLOGY

Age	Formation	Thickness m(ft)	Lithology	Hydrogeology
Holocene	"River-bed sand"	12.2 (40)	Sand, medium to very coarse, poorly sorted	Excellent aquifer. Source of best quality groundwater available
Pleistocene-Pliocene	"Flood-plain deposits"	up to 57.9 (190)	Silt, sandy silt, clayey silt, minor clay, sand and gravel	Contains minor aquifers; best quality water adjacent to Gascoyne River
	UNCONFORMITY			
Cainozoic	Undifferentiated (?Cardabia Group)	over 61.0 (200)	Bentonitic claystones, silt, calcarenite, limestone	No major aquifer potential; calcarenites contain salt water
	UNCONFORMITY			
	Korojon Calcarenite	over 61.0 (200)	Calcinitite, fossiliferous, slightly phosphatic	No aquifer potential
Upper Cretaceous	Toolonga Calcilutite	over 61.0 (200)	Siltstone, slightly silty, calcareous with minor beds of fine sandstone	No major aquifer potential; minor sandstones contain good quality water near Rocky Pool
	Gearle Siltstone	17.4 (57)	Shale, slightly calcareous, fossiliferous	No aquifer potential
	Windalia Radiolarite	23.8 (78)	Shale and radiolarite, interbedded, pyritic	No aquifer potential
Lower Cretaceous	Muderong Shale	12.2 (40)	Siltstone, slightly calcareous	No aquifer potential
	Birdrong Formation	45.7 (150)	Siltstone and silty sandstone, carbonate	Major regional artesian aquifer contains brackish to salt water
	UNCONFORMITY			
Permian	Undifferentiated		Shale and siltstone	No aquifer potential

### HYDROGEOLOGY

#### GROUNDWATER SYSTEM

A regional water table occurs beneath the coastal plain (Plate 4). Below this the Cretaceous and post-Cretaceous sediments are saturated with groundwater. However, sands or sandstones capable of storing and transmitting large quantities of water are only poorly developed in the geological sequence and furthermore much of the groundwater in the region is far below the standard of quality required to meet either irrigation or domestic needs. The principal aquifers are:

- (1) river-bed sand;
- (2) sands within the flood-plain deposits;
- (3) minor beds of sandstone in the Toolonga Calcilutite;
- (4) the Birdrong Formation.

The groundwater which they contain is mainly derived from flow in the Gascoyne River and to a minor extent from local runoff and rainfall.

Apart from some direct recharge, the groundwater system is primarily dependent on the river-bed sand which intercepts and stores a small proportion of the intermittent river flows. This water is then depleted by evapotranspiration except for a proportion which infiltrates downwards and laterally into the flood-plain deposits, and into the

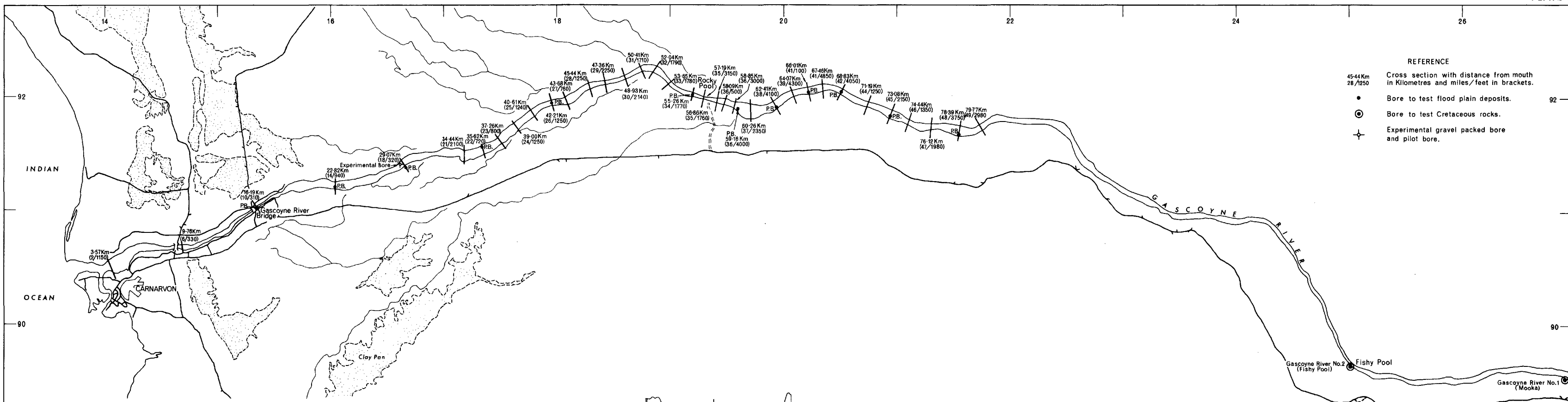
Cretaceous rocks either directly or via the flood-plain deposits. Without the river-bed sand to facilitate quick infiltration, river discharge would probably be too rapid to allow significant amounts of recharge.

#### RIVER-BED SAND

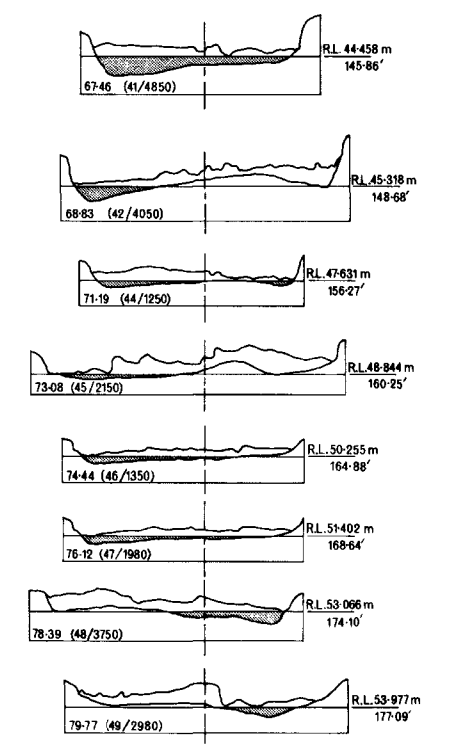
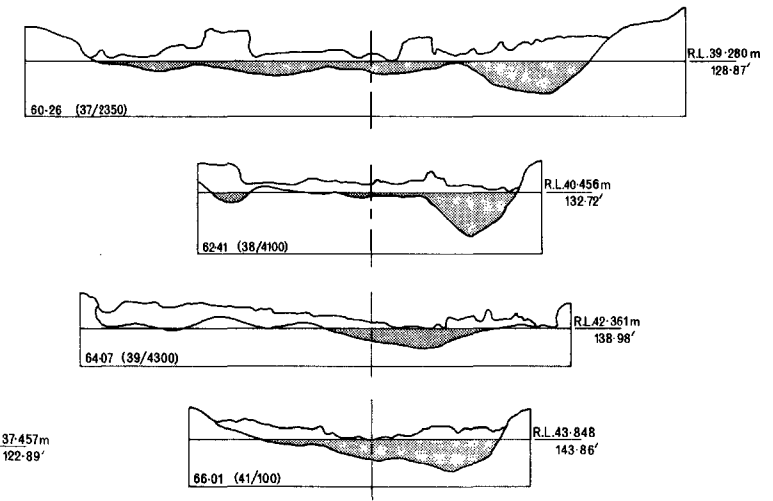
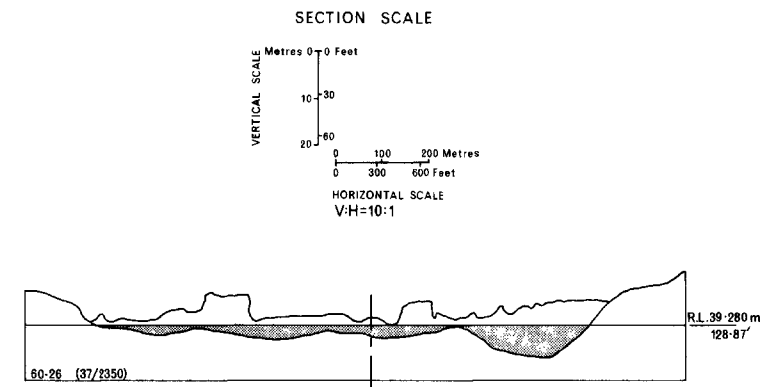
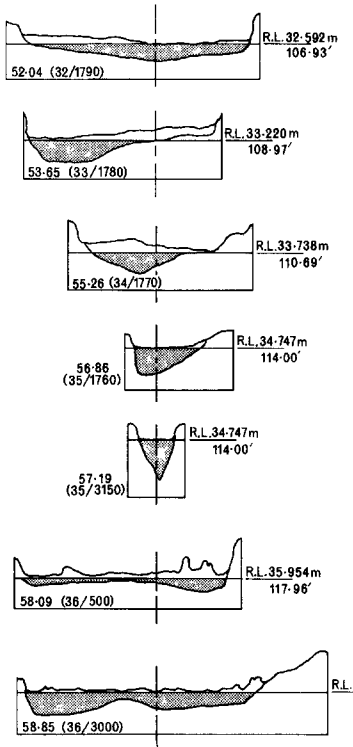
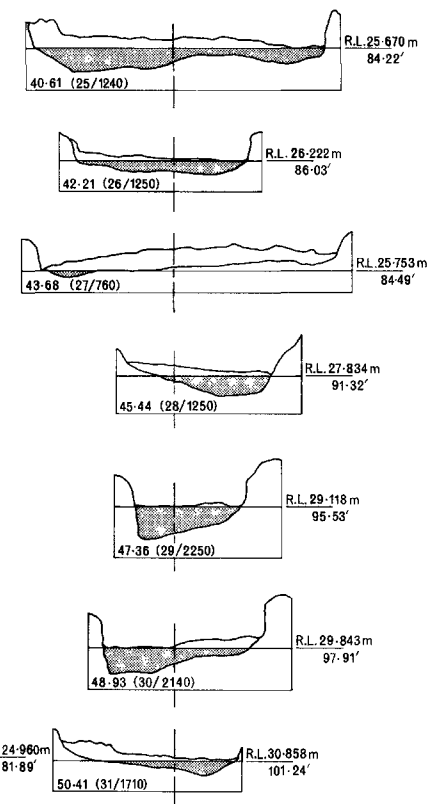
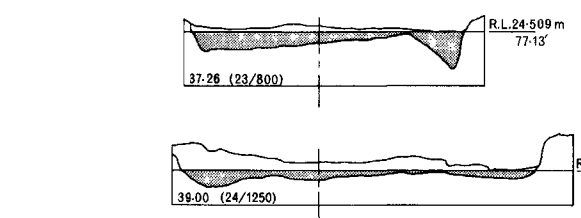
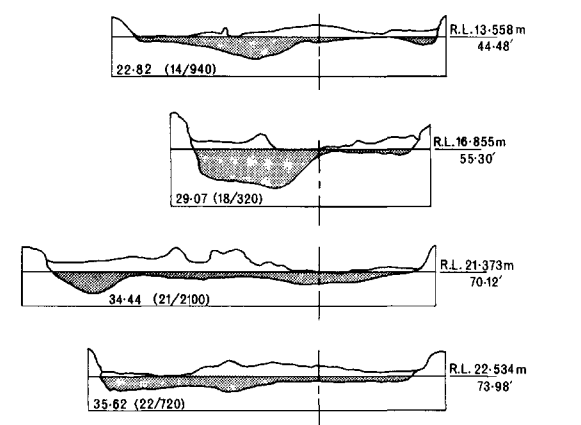
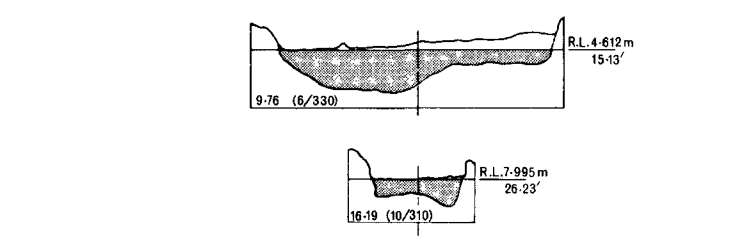
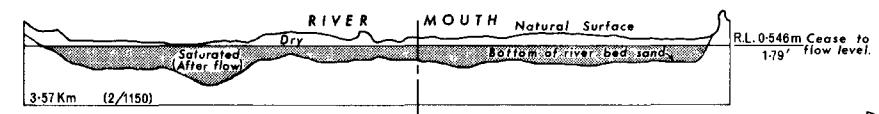
##### Description

The river-bed sand lies in a well-defined channel incised into the underlying flood-plain deposits and, at Rocky Pool, the Cretaceous sediments. In the river bed the sand varies considerably in thickness but does not exceed 10.7 metres (35 ft) below the cease-to-flow level (Plate 3). It tends to become thinner upstream. Drilling samples show the sand to be poorly sorted and of a medium to coarse grading with minor beds of fine-grained and silty or slightly clayey sand.

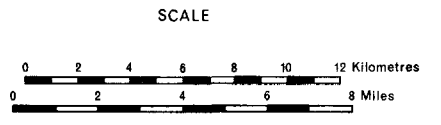
Data from pumping tests of variable reliability indicate that the permeability of the river-bed sand ranges from 24.5 to 734 m<sup>3</sup>/day/m<sup>2</sup> (500 to 15,000 gpd/ft<sup>2</sup>). Values for specific yield, computed by various methods, range between 0.15 and 0.35. For the purpose of calculation a permeability of 24.5 m<sup>3</sup>/day/m<sup>2</sup> (5,000 gpd/ft<sup>2</sup>) and a specific yield of 0.25 have been adopted.

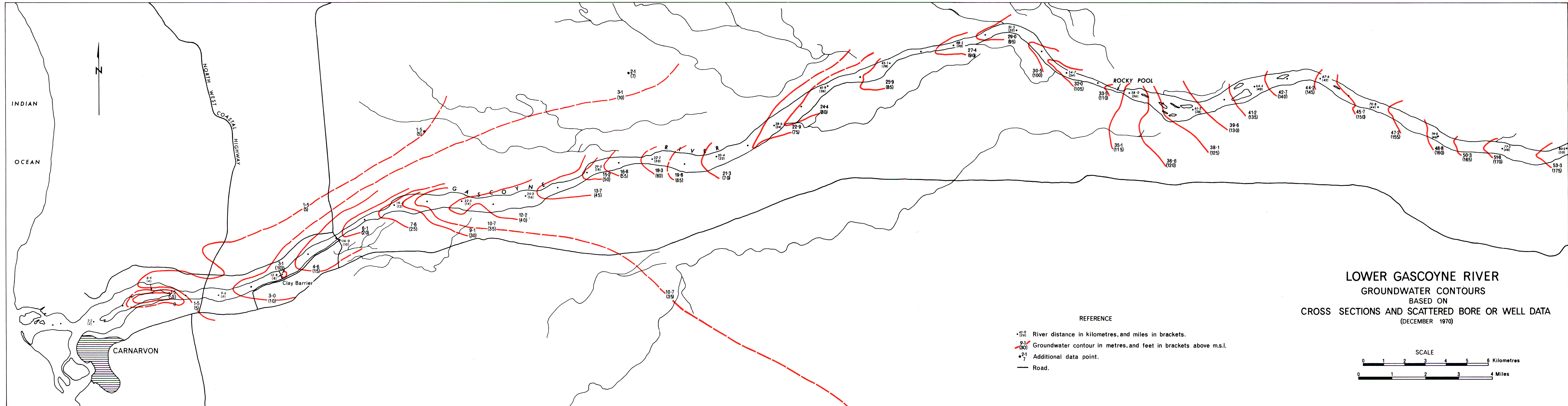


- REFERENCE
- 45-44 Km 28/1250 Cross section with distance from mouth in Kilometres and miles/feet in brackets.
  - Bore to test flood plain deposits.
  - ⊙ Bore to test Cretaceous rocks.
  - ⊕ Experimental gravel packed bore and pilot bore.



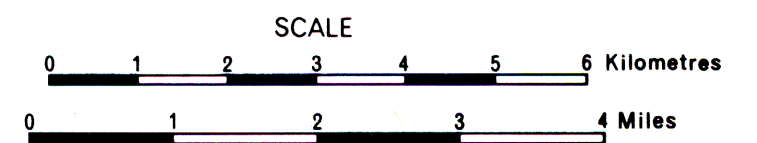
LOWER GASCOYNE RIVER  
LOCATION OF INVESTIGATION PROGRAMME,  
AND  
RESULTANT CROSS SECTIONS





**LOWER GASCOYNE RIVER**  
**GROUNDWATER CONTOURS**  
 BASED ON  
**CROSS SECTIONS AND SCATTERED BORE OR WELL DATA**  
 (DECEMBER 1970)

- REFERENCE
- 21.2 / (26) River distance in kilometres, and miles in brackets.
  - 2.1 / (30) Groundwater contour in metres, and feet in brackets above m.s.l.
  - 2.1 / 7 Additional data point.
  - Road.



### Occurrence of groundwater

By the time a river flow ceases, the river-bed sand is saturated up to the cease-to-flow level (C.T.F.). The groundwater is then gradually depleted at a measured average rate of about 15.2 centimetres (6 in) per month. The water table has a gradient down the river of  $0.25$  to  $0.74 \times 10^{-3}$  (1.3 to 3.93 ft/mile) and averages  $0.485 \times 10^{-3}$  (2.56 ft/mile). However, the gradient laterally into the flood-plain deposits is much steeper at about  $5.68 \times 10^{-3}$  (30 ft/mile). The water table forms a marked groundwater ridge along the length of the river (Plate 4).

The total volume of river-bed sand available for groundwater storage in the reach between 9.76 and 79.77 kilometres (6/330 to 49/2980 miles) is calculable from the cross-sectional areas below the C.T.F. level and the distances between the successive sections (approximately 1.6 kilometres or 1 mile). Some interpolation from existing data between 9.7 and 33.8 kilometres (6 and 21 miles) was also necessary. This volume was computed to be  $80.3 \times 10^6$  cubic metres (2,834 million feet<sup>3</sup>). Applying a specific yield of 0.25, the volume of groundwater in storage is estimated to be 20.1 million cubic metres (16,260 acre ft) or an average of 287,000 m<sup>3</sup>/km (378 acre ft/mile). Significantly, the volume of available groundwater storage declines markedly upstream of about 68.83 kilometres (42/4050 miles) and probably only minor groundwater resources occur in the river-bed sand beyond this point (Plate 3).

An isopach map (not shown) adjusted for the water table gradient and showing the extent and configuration of saturated river-bed sand from 10.1 to 32.3 kilometres (6.6 to 20.1 miles) A.R.M. was prepared from existing detailed P.W.D. data. This showed that 6.17 million cubic metres (5,000 acre ft) or 278,000 m<sup>3</sup>/km (362 acre ft/mile) is in storage at C.T.F., and agrees remarkably well with estimates based on the cross-sectional areas.

### Rainfall replenishment

Local replenishment of groundwater from rainfall may take place along parts of the river bed in the absence of surface flow. The amount of replenishment depends on factors such as depth to water table, intensity of rainfall and whether there had been preceding rainfall. Two observed rainfall events indicate that about 38 millimetres (1.5 in) are required before significant replenishment takes place.

An assessment of the relative importance of rainfall has been made by estimating from the cross sections the area of river bed underlain by saturated river-bed sand. Then by applying the average Carnarvon rainfall, it is possible to calculate that 6.35 million cubic metres (5,150 acre ft) of rainfall fell on the river bed between 9.7 and 78.9 kilometres (6 and 49 miles) A.R.M. A large proportion of this would be lost by evapotranspiration in making up soil-moisture deficit, but if allowance is made for the intensity of rainfall events in the areas it is likely that at least 10 per cent (0.63 million cubic metres or 515 acre ft) recharges the river-bed sand.

### Replenishment by surface runoff

A large number of small drainage systems upstream of Rocky Pool are developed along the banks of the river and these discharge into the river bed. Their runoff has been observed to cause local rises in the water table. The area of the catchments has been measured, and from various considerations it is estimated that 0.94 million cubic metres (765 acre ft) (40 per cent of average rainfall on catchments) is discharged onto the river-bed sand and is therefore an important local source of recharge.

### Depletion by evaporation

After a river flow, groundwater in the river-bed sand is depleted by evaporation from the capillary fringe and from pools caused by local over-deepening of the river bed. The capillary fringe has been observed to extend about 45.7 centimetres (1.5 ft)

above the water table and it seems likely that evaporation does not take place when the water table is 61 centimetres (2 ft) or more below the surface. At the observed rate of water level decline, 15.2 centimetres per month (6 in/month), evaporation would be negligible (except from pools) after 4 months when the water table would be 61 centimetres (2 ft) below C.T.F. level.

The areas over which the water table is 61 centimetres (2 ft) or less below the natural surface have been calculated from cross sections, and averaged for periods of decline below the C.T.F. level of 30.5 centimetres (1 ft) and 61.0 centimetres (2 ft). Then if the assumption is made that evaporation takes place at a quarter of the average rate for a free water surface over a 4-month period, it is possible to calculate that the loss in this time would be 0.66 million cubic metres (535 acre ft), taking only partial account of evaporation from pools.

Although further decline of the water table drastically reduces further evaporative losses, it is clear that if the foregoing assumptions are of the correct order, then evaporation causes significant losses which more than offset estimated direct recharge from rainfall.

### Depletion by transpiration

The appearance and stature of trees which line and in places grow in the river bed, compared with vegetation at only a short distance from the river, clearly indicate that the river gums (*Eucalyptus camaldulensis*) and the paper barks (*Melaleuca* sp.) are phreatophytes.

To evaluate the order of magnitude of depletion by transpiration a crude water balance study was made of a section of river near Rocky Pool. At this locality the river-bed sand is underlain by practically impermeable Toolonga Calcilitite, and a period was selected when the water table was more than 61 centimetres (2 ft) below surface, obviating most of the evaporation losses.

The groundwater inflow through section 36/3000 at 58.8 kilometres and its outflow through section 36/500 at 58.1 kilometres is calculable from a knowledge of the respective cross-sectional areas, the ground-water gradients and the assumed permeability value. The change in storage during the period of study may also be calculated, using the assumed value for specific yield of 0.25 applied to the volume of aquifer desaturated. The transpiration loss is then equal to the inflow plus storage change, less the outflow. This is calculated to be about 15,500 cubic metres (12.6 acre ft) for the period 4th to 21st March, 1970.

If this amount of transpiration is assumed to take place from the plan area of the tree canopy (which is measurable from air-photographs), then the unit rate can be derived. This is 11.7 centimetres (4.6 in).

The average evaporation loss from a free water surface in the area, based on Commonwealth Bureau of Meteorology Charts is 12.4 centimetres (4.9 in) for the same period, so that the relationship between transpiration and evaporation losses is in the proportion of 11.7 to 12.4. Knowing the mean annual potential evaporation to be 216 centimetres (85 in), we can calculate that the transpiration losses are 11.7/12.4 of this, giving an estimated total annual transpiration loss of  $8.67 \times 10^6$  cubic metres (7,024 acre ft) from the measured area of tree canopy along the river.

If the various assumptions are correct, then transpiration is the major process depleting groundwater in the river-bed sand.

### Depletion by vertical infiltration

Observation showed that a small vertical head differential existed between water in the river-bed sand and in the flood-plain deposits. Vertical infiltration from the river-bed sand to the flood-plain deposits was estimated using a modification of the Darcy equation after Walton (1962, p. 22). The area over which this could occur was estimated from the cross sections.



The head difference across the interface between river-bed sand and flood-plain deposits was taken as 15.2 centimetres (6 in) and the confining bed assumed to be 30.48 centimetres (1 ft) thick, with a vertical permeability of  $4.89 \times 10^{-4} \text{ m}^3/\text{day}/\text{m}^2$  (0.01 gpd/ft<sup>2</sup>). This value for permeability has been verified to some extent by leaky artesian response analysis. The resulting estimate of annual vertical infiltration was 2.67 million cubic metres (2,165 acre ft).

#### Subsurface inflow and outflow

Knowing the cross-sectional areas and the river gradient, and applying the adopted value for permeability, the total inflow at the 79.77-kilometre (49/2980) section over 1 year was estimated to be 5,550 cubic metres (4.5 acre ft) while the outflow at the cross section, 9.76 kilometres (6/330), was estimated to be 0.228 million cubic metres (185 acre ft), both calculations being adjusted for a 1.83-metre (6 ft) decline in water level over the period.

#### Groundwater balance

Various estimates have been made in the foregoing account of the magnitude of factors contributing to, or depleting water from, the river-bed sand in the reach between 9.7 and 78.9 kilometres (6 and 49 miles) A.R.M. over 1 year after a river flow. The groundwater balance for the assumed model, exclusive of pumped abstraction, can be expressed in the form of the following equation:

$$Q = P + R_L + U_i - (E + T_r + U_o + V_1)$$

where  $Q$  is increase or decrease in groundwater storage after 1 year,  $P$  is direct replenishment from rainfall,  $R_L$  is replenishment from local runoff,  $U_i$  is underflow into the system,  $E$  is evaporation,  $T_r$  is transpiration,  $U_o$  is underflow out of the system, and  $V_1$  is vertical infiltration into the flood-plain deposits, all expressed in common units. Substituting derived values:

$$Q = 0.63 + 0.94 + 0.006 - (0.66 + 8.65 + 0.23 + 2.67) \\ = -10.64 \times 10^6 \text{ cubic metres (8,624 acre ft).}$$

This figure can be checked by computing from the cross sections the volume of river-bed sand that has been desaturated as a result of the projected water level decline of 1.83 metres (6 ft) over 1 year. The volume of water lost from storage can then be derived by applying the assumed storage coefficient of 0.25. This has been estimated to be 11.2 million cubic metres (9,065 acre ft) which is within 6 per cent of the previous estimate. This is a remarkably close agreement considering the basis for many of the estimates. Whether the results for individual items are of the correct order or whether compensating errors have been introduced is not certain, and more refined calculations should be undertaken at suitable opportunities.

#### FLOOD-PLAIN DEPOSITS

##### Description

The flood-plain deposits consist predominantly of silt, clayey and sandy silt, and minor sand, clay and gravel. Controlled pumping tests indicate that aquifers have a very variable permeability ranging from 1.8 to  $150 \text{ m}^3/\text{day}/\text{m}^2$  (36 to 3,000 gpd/ft<sup>2</sup>) reflecting the variable nature of the aquifers. In contrast to these figures the average permeability of the flood-plain deposits as a whole is considered to be of the order  $4.9 \times 10^{-3} \text{ m}^3/\text{day}/\text{m}^2$  (1.0 gpd/ft<sup>2</sup>).

##### Occurrence of Groundwater

The flood-plain deposits include a number of lenticular aquifers in hydraulic connection with the river-bed sand. There is a regional water table within these deposits which has a gradient of about  $5.7 \times 10^{-3}$  (30 ft/mile) (Plate 4) away from the river.

Some aquifers have hydraulic heads slightly higher or lower than the water table, indicative of at least partially confined conditions. These are reflected by the aquifer response characteristics during test pumping, and computed storage coefficients in the range of  $1.0 \times 10^{-4}$  to  $1.0 \times 10^{-7}$ . The rapid rises of water level observed during times of river flow are a consequence of semi-confined conditions.

The volume of groundwater in storage in the flood-plain deposits is very large, but the quantity in storage which is of suitable quality and is extractable is relatively small. It is restricted to beneath the river bed and its immediate vicinity. The best quality water occurs immediately below the river but it is known to deteriorate rapidly with distance away from it. The present drilling information is insufficient to define the width of the zone of usable groundwater but data in Baxter (1968) have shown that it extends about 0.4 kilometres (quarter of a mile) from the river bank.

The quantity in storage may be estimated by assuming that the zone of good quality water extends 305 metres (1,000 ft) on either side of saturated river-bed sands (from cross sections); that the average thickness of the flood-plain deposits is 47 metres (155 ft); and that the specific yield is 0.05. The estimated volume in storage between 10 and 79 kilometres (6 and 49 miles) A.R.M. is 152 million cubic metres (123,000 acre ft). This estimate is probably conservative. However, the annual rate of renewal of the resource from the river-bed sand (as previously estimated) is only 2.67 million cubic metres (2,165 acre ft), which is equivalent to  $38.6 \times 10^6 \text{ m}^3/\text{km}/\text{year}$  (50 acre ft/mile/year).

#### CRETACEOUS SEDIMENTS

The only sources of good quality water discovered in the Cretaceous rocks are several minor sandstones which occur in the Toolonga Calcilitite in the vicinity of Rocky Pool. If developed these could provide small supplementary supplies.

The Birdrong Formation, where tested, contains water of 1,480 ppm TDS (Table 3), too saline for irrigation purposes, with a static head of about 88.4 metres (290 ft) above sea level. A bailing test indicated that large supplies are probably available, but it is most unlikely, if at all, that it contains water suitable for irrigation within 145 kilometres (90 miles) of Carnarvon.

The other Cretaceous formations consist predominantly of silt or shale and have no aquifer potential.

#### GROUNDWATER QUALITY

Groundwater quality in the Carnarvon area is very important because of the effects which dissolved salts have on soil structure and plant or human physiology. The total dissolved salt content, boron and fluoride levels of groundwater have all imposed limitations at various times on water use both as a source of township supply and for irrigation.

Variations in the total dissolved solid content of groundwater tend to follow a pattern and are therefore predictable to a certain extent, but no pattern has been found to the occurrence of boron and fluoride, and each source has to be assessed as found.

##### Total dissolved solids

The West Australian Department of Agriculture has recommended that water for irrigation at Carnarvon should contain not more than 350 ppm TDS. However, sampling by the Public Works Department of pumped groundwater between 1966 and 1968 showed that the average quality of water abstracted from the river-bed sand was 320 ppm of sodium chloride (690 ppm TDS approximately) and from the flood-plain deposits was 426 ppm sodium chloride (880 ppm TDS approximately). Furthermore, in any 1 year the quality of the

TABLE 3. WATER ANALYSES, DRILLED BORES AND RIVER FLOWS

Name, Depth and Remarks	Date	C @ 20°C	pH	T.D.S. (evap)	T.D.S. (cond)	T. Hard CaCO <sub>3</sub>	T. Alk CaCO <sub>3</sub>	Ca	Mg	Na	K	HCO <sub>3</sub>	CO <sub>3</sub>	SO <sub>4</sub>	Cl	NO <sub>3</sub>	SiO <sub>2</sub>	Fe (soln)	F	B	SAR	Na %	Free CO <sub>2</sub>	Mn
RIVER FLOW																								
Gascoyne R Lead Water, 22/1/67	7/2/67	290	7.2	200	...	...	...	25	7	32	5	116	...	...	35	...	...	...	...	0.2	1.5	43	...	...
Gascoyne R Lead Water, 30/1/68	7/2/68	440	6.7	360	...	158	160	32	19	46	12	195	...	...	79	...	...	...	...	0.2	0.6	1.6	39	...
Gascoyne R Flow, 5/2/68	9/2/68	190	7.0	140	...	58	55	15	5	18	5	67	...	...	22	...	...	...	...	0.5	0.3	1.0	40	...
Gascoyne R Flow c. 11/4/68	11/4/68	...	7.9	310	...	108	70	24	11	...	...	...	...	...	...	...	...	...	...	0.2	...	...	...	...
Gascoyne R Lead Water, 18/6/68	2/7/68	310	7.1	190	...	56	45	14	5	51	...	55	...	...	62	...	...	...	...	0.1	0.1	2.9	67	...
Gascoyne R 2 hours after lead, 24/2/69	24/2/69	250	6.8	180	...	...	62	19	7	23	...	76	...	...	44	...	...	...	...	0.1	0.2	1.1	40	...
Gascoyne R Lead Water, 24/2/69	24/2/69	510	6.7	330	...	...	155	39	15	52	15	139	...	...	93	...	...	...	...	0.3	0.2	1.8	42	...
Gascoyne R Lead Water, 21/5/69	21/5/69	360	7.8	250	...	116	108	30	10	46	6	131	...	...	52	...	...	...	...	0.2	0.2	1.9	46	...
Gascoyne R 2 hours after lead, 21/5/69	21/5/69	260	7.7	250	...	69	52	16	7	26	5	63	...	...	38	...	...	...	...	0.2	0.1	1.4	45	...
Gascoyne R Lead Water, 2/6/70	2/6/70	...	7.1	340	...	110	52	26	11	71	...	63	...	...	112	...	...	...	...	0.3	0.3	2.9	58	...
Gascoyne R 2 hours after lead, 2/6/70	2/6/70	...	6.9	290	...	85	45	21	8	56	...	55	...	...	84	...	...	...	...	0.3	0.3	2.6	59	...
Gascoyne R Flow Inlet to Rocky Pool	11/8/70	1,000	8.0	600	700	214	105	46	24	138	8	128	...	103	221	<1	12	<0.05	...	...	...	...	...	...
Gascoyne R Flow 33-mile x section	11/8/70	820	8.6	520	570	174	100	40	18	110	7	110	6	74	173	<1	12	<0.05	...	...	...	...	...	...
PERCUSSION BORES																								
37/2350/7/ 59 ft	27/12/69	940	7.5	570	660	294	98	63	33	81	12	119	...	56	232	1	13	0.2	...	...	...	...	...	...
GR No. 1 Mooka	13/8/70	...	7.9	1,480	...	356	315	57	52	321	...	383	...	...	509	1	...	...	...	1.1	...	...	...	...
43-mile x section start pump test	12/11/70	710	7.7	500	...	...	...	...	...	...	...	...	...	...	...	...	...	0.10	...	...	...	...	...	...
43-mile x section end pump test	14/11/70	700	7.8	480	...	165	140	35	19	89	...	171	...	...	76	...	...	...	...	0.3	0.3	3.0	54	4 <0.05
45-mile x section start pump test	28/11/70	570	7.6	...	...	400	...	...	...	...	...	...	...	...	...	...	...	...	...	...	...	...	...	...
45-mile x section end pump test	30/11/70	570	7.7	370	400	121	143	27	13	75	6	174	...	50	67	4	47	<0.05	...	0.3	0.3	...	...	<0.05
42-mile x section start pump test	30/12/70	1,050	7.7	680	...	...	...	...	...	...	...	...	...	...	...	...	...	<0.05	...	...	...	...	...	...
42-mile x section end pump test	30/12/70	1,050	7.6	680	...	195	105	37	25	134	...	128	...	...	...	...	...	...	...	1.4	0.4	0.3	4.2	60 <0.05
38-mile x section bailed	...	400	7.5	300	280	89	120	21	9	56	5	146	...	33	44	3	44	<0.05	...	0.4	0.2	...	...	<0.05
38-mile x section bailed	...	540	7.4	350	380	109	133	22	13	71	8	162	...	40	67	5	39	0.10	...	0.5	0.3	...	...	<0.05
38-mile x section start pump test	28/9/70	430	7.4	...	300	...	...	...	...	...	...	...	...	...	...	...	...	...	...	...	...	...	...	...
38-mile x section end pump test	30/9/70	400	7.9	260	280	129	98	30	13	33	5	119	...	28	55	4	33	<0.05	...	0.4	0.2	...	...	<0.05
38-mile x section start pump test	1/10/70	450	9.0	320	320	97	125	21	11	62	6	128	12	26	62	...	52	0.07	...	0.6	0.2	...	...	...
38-mile x section end pump test	1/10/70	470	7.9	320	330	99	122	20	12	64	6	149	...	28	65	4	51	0.05	...	0.6	0.2	...	...	...
36-mile x section start pump test	14/12/70	1,230	7.5	800	...	...	...	...	...	...	...	...	...	...	...	...	...	...	...	...	...	...	...	...
36-mile x section end pump test	16/12/70	1,230	7.7	800	...	249	172	47	32	163	...	208	...	...	...	...	...	...	...	...	...	...	...	<0.05
18-mile Pilot Bore (river-bed sand end pump test)	28/9/71	880	7.7	540	...	173	68	38	19	...	...	...	...	...	...	<1	...	<0.05	0.2	0.25	...	...	...	<0.05

water in the river-bed sand is fairly uniform, but from year to year, it may vary quite markedly. This reflects the differences in river-flow salinities from one flood to another, according to the particular part of the catchment area which contributes most runoff.

The salinity of the water from the flood-plain deposits is much less uniform, but does not show such marked changes from year to year.

During the present investigation more than 1,000 analyses have been made, mainly of water from the river-bed sand. They indicate that the quality of groundwater available from the river-bed sand is generally in the range 300 to 500 ppm TDS.

#### Boron

The recommended limit for boron has been set at 0.5 ppm. It occurs naturally in the groundwater (Table 3) and has been found to affect citrus trees, bananas and beans, if in excess of this limit. Boron has been found to occur in river flows in concentrations of 0.10 to 0.55 ppm and is probably in about the same range of concentrations in the river-bed sand. However, limited sampling has shown a range of 0.3 to 4.9 ppm in the flood-plain deposits, following no apparent pattern.

#### Fluoride

The acceptable limit of fluoride for the town water supply has been set at 1.0 ppm. It has been found that river flows (Table 3) can have concentrations of up to 0.3 ppm and the concentration in the river-bed sand is probably dependent on the quality of the recharging river flow. Up to 7.4 ppm have been recorded in the flood-plain deposits and as in the case of boron no apparent pattern is evident, either areally or with depth.

#### CONCLUSIONS

The largest supplies of good quality groundwater are available in the river-bed sand and the adjacent flood-plain deposits.

The river-bed sand is the most readily exploitable aquifer and also contains the best quality water. The volume in storage after river flows has been reliably assessed, but a study of the water balance indicates quite clearly that natural losses remove about half of this volume after only 1 year.

The estimate of the groundwater resources of the flood-plain deposits is considered to be of the right order of magnitude, despite the limited bore data available. These resources are difficult to develop and of more variable quality than the shallower aquifers. However they do constitute a valuable reserve for use when more readily available resources approach exhaustion.

The groundwater resources are relatively small in relation to the potential demand. They are also restricted in extent and are of variable quality. Therefore careful development and management must be undertaken to obtain optimum abstraction and conservation.

Effective development will be dependent on the location and construction of efficient means of abstraction. At these sites it will be necessary to establish and maintain a network of bores for water level observation and sampling in the river-bed sand and the flood-plain deposits in order to manage their use and so that the ingress of saline water is prevented.

The policy of groundwater management under the existing conditions should be to make use of groundwater in the river-bed sand. Then, as this becomes depleted supplement the supply from the flood-plain deposits until the next flow. Thus the role of the supplies in the flood-plain deposits is as a buffer reserve for use during protracted periods without river flow.

If a dam is built, the impounded water should be used immediately after river flow, thereby reducing the potential evaporation loss, and resultant deterioration in quality of water in the dam. This would also allow rather more recharge from the river-bed sand to the flood-plain deposits than would otherwise take place. Later, before the water in the dam became excessively saline, part or all of the water could be discharged to "top up" storage in the river-bed sand, and groundwater use could then proceed.

#### ACKNOWLEDGEMENTS

The writer wishes to thank Mr. E. E. Schenk, engineer, Public Works Department who organized and contributed substantially to the investigation.

#### REFERENCES

- Allen, A. D., 1972, Cretaceous-Holocene stratigraphy and structure, lower Gascoyne River, Carnarvon Basin: West. Australia Geol. Survey Ann. Rept. 1971, p. 22.
- Baxter, J. L., 1967, Hydrogeological features of the Gascoyne River, west of the Kennedy Range: West. Australia Geol. Survey Ann. Rept. 1966, p. 44-45.
- 1968, Hydrogeology of the Gascoyne River: West. Australia Geol. Survey Rec. 1968/7 (unpublished).
- Condon, M. A., 1962, Kennedy Range, W.A.: Australia Bur. Mineral Resources 1:250,000 Geol. Series Explan. Notes.
- 1968, The geology of the Carnarvon Basin, Western Australia, Part 3, Post-Permian stratigraphy, structure, economic geology: Australia Bur. Mineral Resources Bull. 77.
- Ellis, H. A., 1958, Report on water supply, Carnarvon Plantation area, Carnarvon, W.A.: West. Australia Geol. Survey Bull. 109, p. 9-12.
- Gibb, A. and partners, 1969, Carnarvon water supply report on reconnaissance study: Consultants report to P.W.D. (unpublished).
- Passmore, J. R., 1968, Lower Gascoyne River, possible flow losses downstream from Kennedy Range dam site: West. Australia Geol. Survey Rec. 1968/11 (unpublished).
- Walton, W. C., 1962, Selected analytical methods for well and aquifer evaluation: Illinois State Water Survey Bull. 49.

## CRETACEOUS-HOLOCENE STRATIGRAPHY AND STRUCTURE, LOWER GASCOYNE RIVER, CARNARVON BASIN

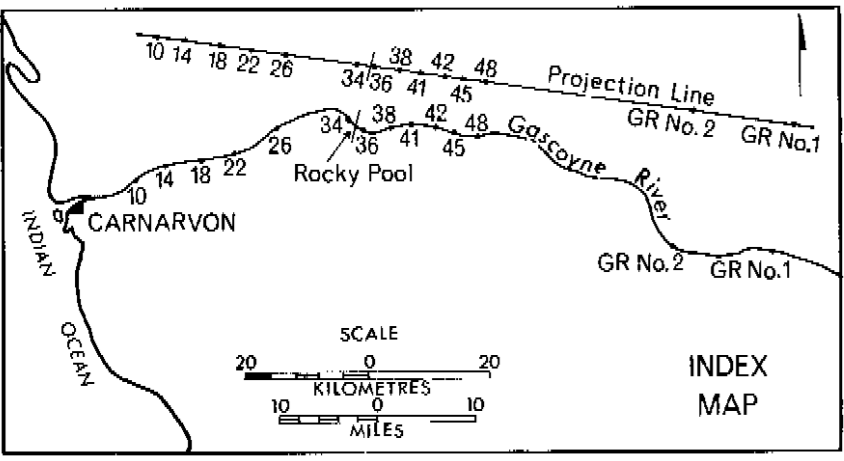
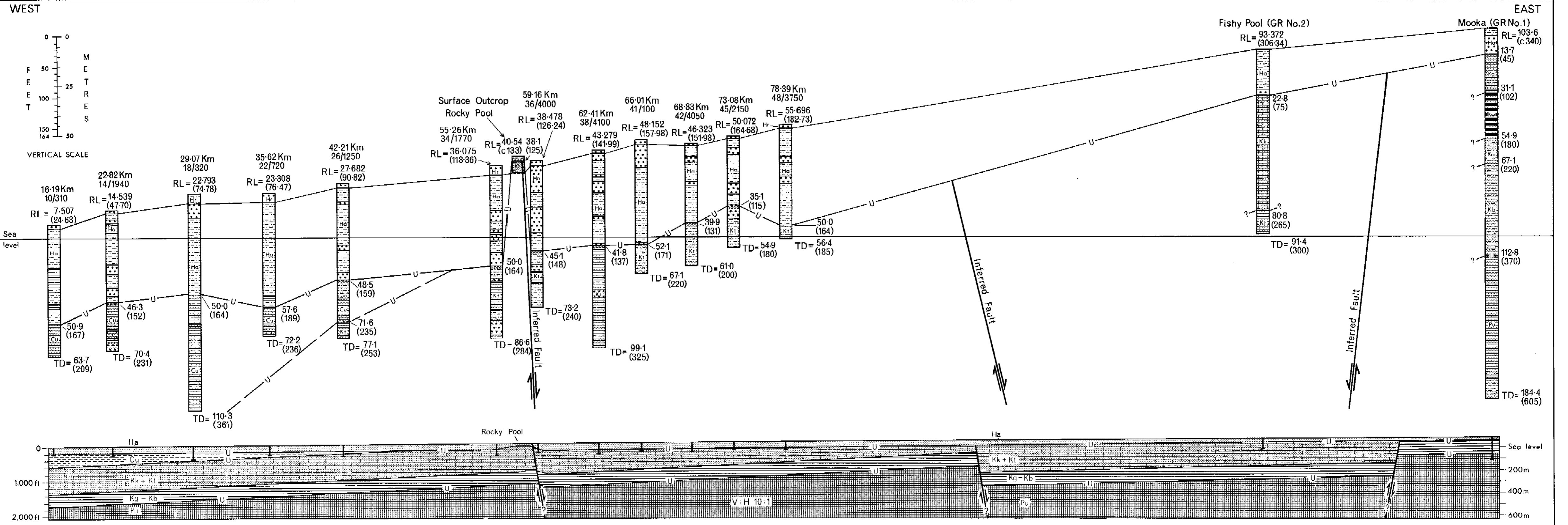
by A. D. Allen

#### ABSTRACT

Data from 14 bores along 121 kilometres (75 miles) of the lower Gascoyne River, in the Carnarvon Basin, show that the concealed Mesozoic-Cainozoic sedimentary rocks exceed 274 metres (900 ft) in thickness and form a faulted sequence which dips gently westward. An asymmetric fold involving the Toolonga Calcilutite (Cretaceous) and Gascoyne alluvium (Pleistocene) exposed at Rocky Pool is interpreted as a drag fold along a fault. Ambiguous evidence is interpreted and it is suggested that the fault is recent and may still be active.

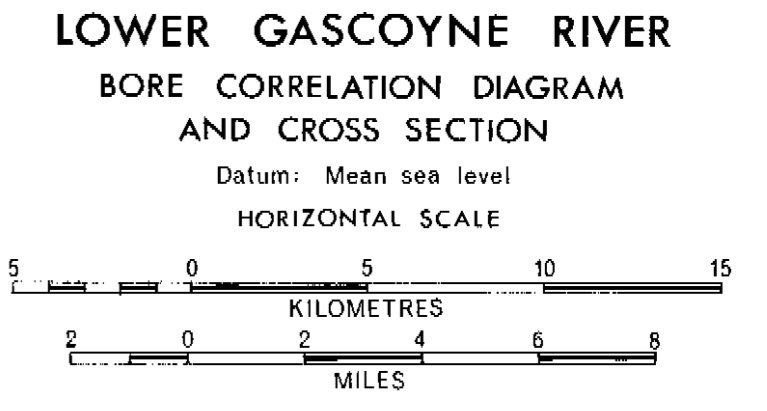
#### INTRODUCTION

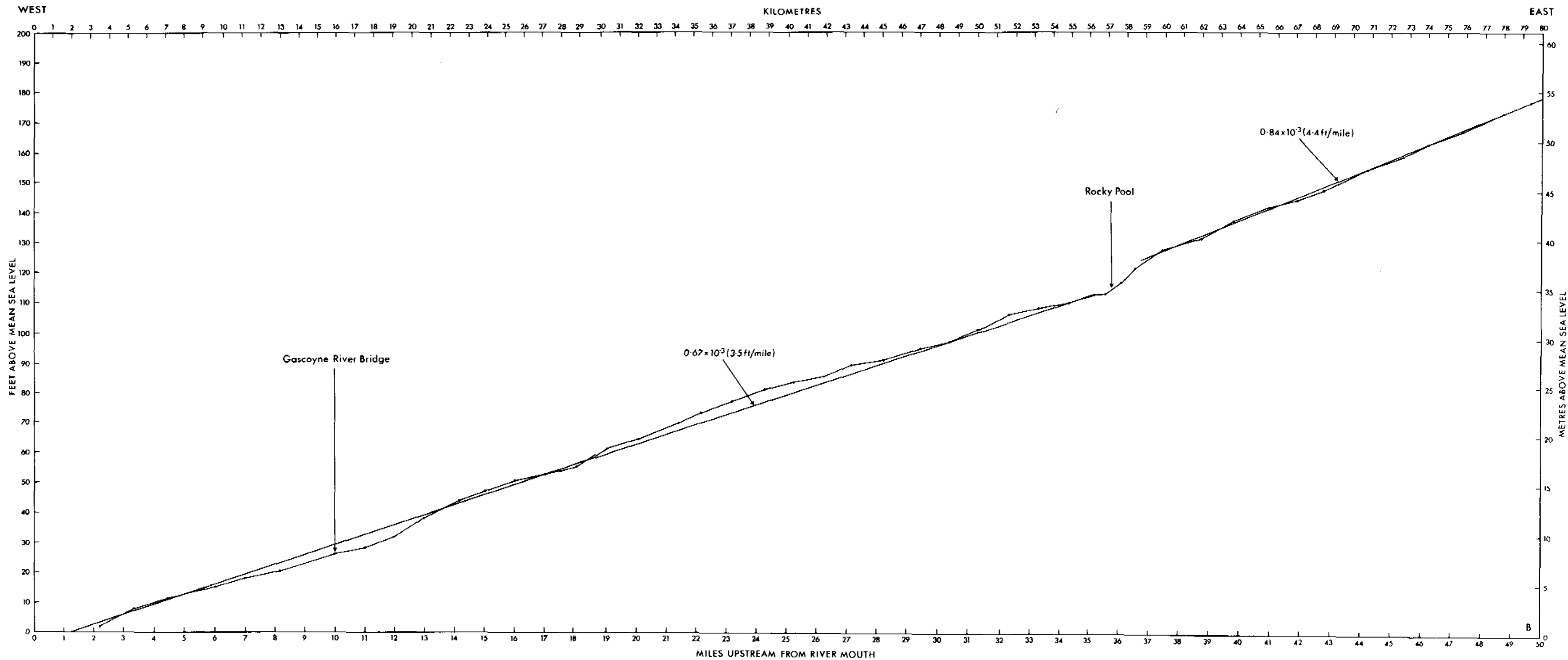
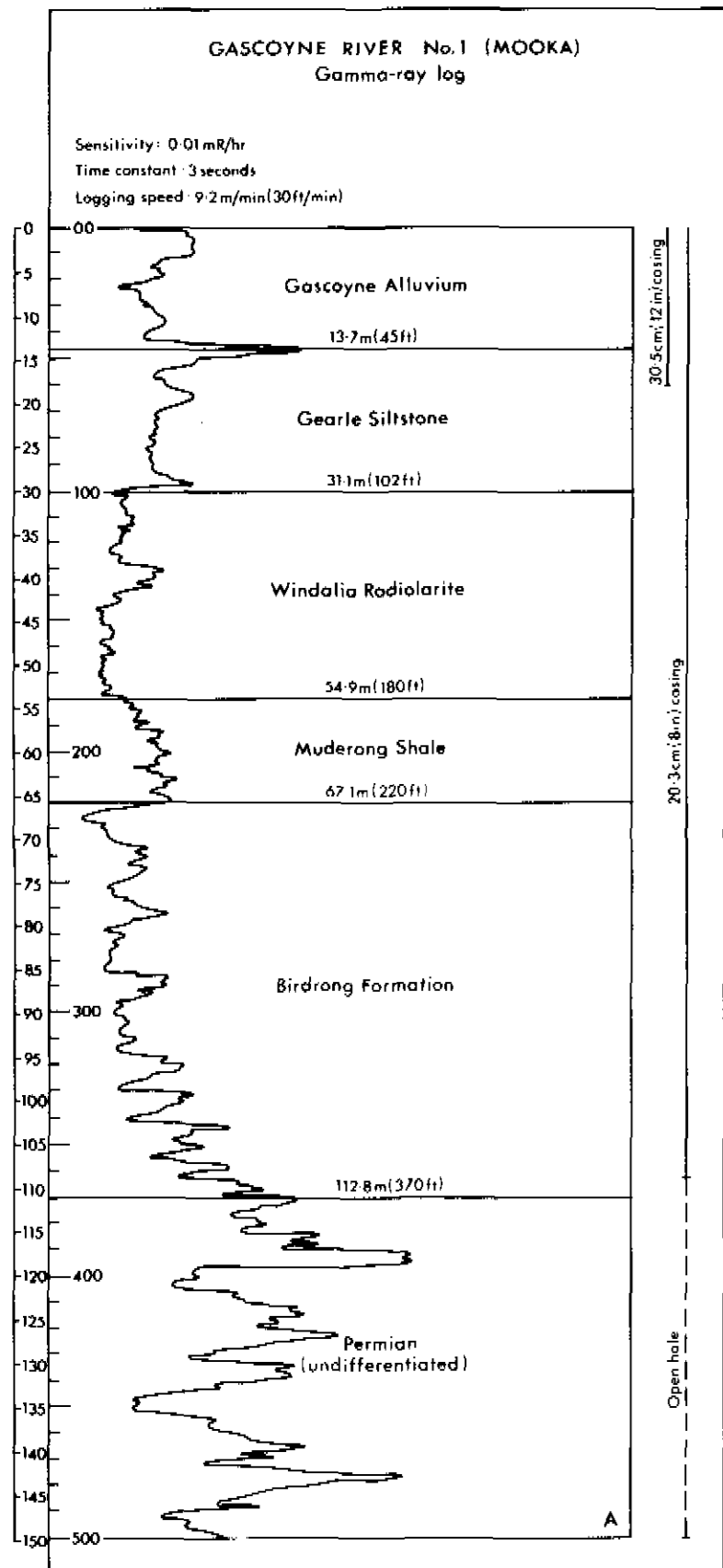
Between November 1969 and October 1971 an investigation into the groundwater resources of the lower Gascoyne River was carried out. One of the objectives was to test the groundwater potential of the various formations which underlie the area. For this purpose two bores, G.R. No. 1 (Mooka) and G.R. No. 2 (Fishy Pool) were drilled to test the Cretaceous Birdrong Formation, and 12 bores drilled to test the potential of the Gascoyne alluvium (inset Plate 5). The latter bores were drilled



**REFERENCE**

<b>STRATIGRAPHY</b>		<b>GENERALIZED LITHOLOGY</b>	
Hr	Holocene: 'River bed sand'	Kg	Cretaceous: Gearle Siltstone
Ha	Holocene: Gascoyne Alluvium	Kw	Cretaceous: Windalia Radiolarite
Cu	Cainozoic: Undifferentiated	Km	Cretaceous: Muderong Shale
Kk	Cretaceous: Korojon Calcarenite	Kb	Cretaceous: Birdrong Formation
Kt	Cretaceous: Toolonga Calcilitite	Pu	Permian: Undifferentiated
		Laterite	Clay/Shale
		Unconformity (U)	Limestone
		Sand/Sandstone	Calcilitite
		Silt/Siltstone	Radiolarite





### LOWER GASCOYNE RIVER

- A. GASCOYNE RIVER No.1 (MOOKA) GAMMA-RAY LOG
- B. LONGITUDINAL PROFILE - GASCOYNE RIVER

through the Gascoyne alluvium, occasionally for some distance, into the Cretaceous or Cainozoic formations.

The bores were drilled with cable-tool (percussion) rigs. Strata samples were taken every 10 feet or change in lithology and these together with detailed logs are held by the Geological Survey. Drilling results are summarized in Table 1.

Gascoyne River No. 1 was gamma-ray logged (Plate 6A). The other bores await similar logging, with the exception of G.R. No. 2, and P.B. 38/4100\* (62.40 kilometres) which have been infilled.

### STRATIGRAPHY

#### GENERAL

The area investigated is in the Gascoyne sub-basin of the Carnarvon Basin. It has been described by Condon (1968) and is on the Kennedy Range 1:250,000 Geological Sheet.

The sub-basin contains Palaeozoic, Mesozoic, and Cainozoic sedimentary rocks, which are separated by regional unconformities. The Palaeozoic rocks are folded and faulted and from geophysical evidence are about 9,150 metres (30,000 ft) thick (Condon, 1968). The overlying Mesozoic and Cainozoic rocks are known from Brickhouse No. 4 bore to be 394 metres (1,200 ft) and 61 metres (200 ft) thick, respectively. They have a gentle regional dip to the west and are locally folded and faulted. A westward-thickening wedge of flood-plain deposits, informally referred to as the Gascoyne alluvium, overlies the Mesozoic and Cainozoic rocks and forms a plain of low relief. The wedge attains a thickness of about 58 metres (190 ft) and mantles the underlying rocks except where they are exposed at Rocky Pool for about 1.6 kilometres (1 mile), or where the river has incised through its former deposits to expose occasional outcrops in the bed or banks from Fishy Pool to Kennedy Range.

TABLE 1. SUMMARY OF DRILLING RESULTS

Name	Distance above river mouth (km)	R.L. (metres)	Depth (metres)	FORMATION (metres below surface) (see Plate 1 Legend)					G.S.W.A. Palaeontology Reports
				Hr + Ha	Cu	Kk	Kt	Kg-Pu*	
PB 10/810	16.19	7.507	66.1	0-50.9	50.9-63.7	...	...	...	...
PB 14/940	22.82	14.539	70.4	0-46.3	46.3-70.4	...	...	...	...
PB 18/320	29.07	22.733	110.3	0-50.0	50.0-110.3	...	...	...	...
PB 22/720	35.62	23.308	72.2	0-57.6	57.6-72.2	...	...	...	...
PB 26/1250	42.21	27.682	77.1	0-48.5	48.5-71.6	...	71.6-77.1	...	47/1971 53/1971
PB 34/1770	55.26	36.075	86.6	0-50.0	...	...	50.0-86.6	...	...
PB 36/4000	59.16	38.478	73.2	0-45.1	...	...	45.1-73.2	...	...
PB 38/4100	62.41	43.279	99.1	0-41.8	...	...	41.8-99.1	...	38/1970 26/1970
PB 41/100	66.01	48.152	67.1	0-52.1	...	...	52.1-67.1	...	38/1970
PB 42/4050	68.83	46.323	61.0	0-39.9	...	...	39.9-61.0	...	38/1970
PB 45/2150	73.08	50.072	54.9	0-35.1	...	...	35.1-54.9	...	38/1970
PB 48/3750	78.39	55.696	56.4	0-50.0	...	...	50.0-56.4	...	38/1970
G.R. No. 1	...	c. 103.6	184.4	0-13.7	...	...	...	13.7-184.4*	20/1970
G.R. No. 2	...	93.372	91.4	0-22.8	...	22.8-80.8	80.8-91.4	...	22/1970

Note: 1 m = 3.281 ft  
\* See Inset A Figure 1

The established Cretaceous-Lower Cainozoic stratigraphic sequence (Condon, 1968; Playford and Cope, 1971), and the rock units recognized are as follows:

Age	Group	Formation		Known maximum thickness metres*
		Established	Recognized	
Cainozoic	?Cardabia	various	undifferentiated	152
U.Cretaceous	...	Miria Marl	not recognized	} 273
		Korojon Calcarenite		
		Toolonga Calclutite		
L.Cretaceous	Winning	Alinga Greensand	not recognized	588
	"	Gearle Siltstone		30
	"	Windalia Radiolarite		215
	"	Muderong Shale		...
	"	Birdrong Formation		...
Permian	...	various	undifferentiated	...

\* 1 m = 3.281 ft

#### RESULTS OF DRILLING

##### Undifferentiated Permian Formation

Shale and siltstone presumed to be of Permian age (Condon, 1968, Fig. 146) were encountered in G.R. No. 1 from 112.6 to 184.2 metres (370 to 605 ft). They were grey with pink, white, and grey-green laminae and mottling.

The shales showed prominent lamination and contained silty micaceous layers as well as rare carbonaceous material and pyrite. Slightly calcareous siltstone with a faint petroliferous odour was encountered from 174 to 184 metres (572 to 605 ft).

The distinctive colouration of the section (a possible result of sub-aerial weathering) and gamma-log expression distinguished it from the inferred unconformably overlying Birdrong Formation.

Samples taken for palynological examination contained no identifiable palynomorphs and only unidentifiable plant tissue (Ingram, 1970a).

##### Birdrong Formation

A complete section of the Birdrong Formation is believed to have been penetrated in G.R. No. 1 from 67 to 112.6 metres (220 to 370 ft) below surface. It is presumed to unconformably overlie undifferentiated Permian sedimentary rocks and is conformably overlain by the Muderong Shale.

The formation consists of grey coarse siltstone grading downwards to a very fine silty sandstone at its base. It is carbonaceous from 77.8 to 112.9 metres (255 to 370 ft), and contains rare pyrite, and scattered glauconite grains at 96 metres (315 ft). The sand fraction is very well rounded.

In contrast with the lithological log, the gamma log (Plate 6A) indicates that the formation consists of alternating layers of silt and sand (or sandy silt) becoming more sandy towards the bottom. The apparent discrepancy is thought to result from the abundance of carbonaceous material towards the base of the formation.

Samples from 71.6 and 99 metres (235 and 325 ft) contain microplankton and palynomorphs indicating a Neocomian-Aptian age (Ingram, 1970a).

##### Muderong Shale

The Muderong Shale is inferred to be represented by a well-defined shale occurring conformably below the lithologically distinctive Windalia Radiolarite and conformably overlying the Birdrong Formation, from 55 to 67 metres (180 to 220 ft) below surface in G.R. No. 1.

\* P.B. 38/4100 (62.40 kilometres) stands for percussion bore with the river distance as measured from the river mouth. Note that the Gascoyne River bridge is 16.18 kilometres (10 miles) above the mouth.

Lithologically the formation consists of a dark grey siltstone with light and dark laminae. It is slightly calcareous, and contains frequent scattered subangular to well rounded quartz grains and occasional layers of massive pyrite. The siltstone also has a distinctive gamma-ray log expression (Plate 6A). Its age was not determined as no palaeontological examination was made of any samples.

#### *Windalia Radiolarite*

The Windalia Radiolarite was encountered between 31 and 55 metres (102 and 180 ft) below surface in G.R. No. 1 and is apparently conformably underlain and overlain by the Muderong Shale and Gearle Siltstone respectively. It consists of a distinctive sequence of alternating thin beds of black shale and black hard radiolarite. Some layers are slightly calcareous, and nodules or layers of euhedral and massive pyrite occur throughout. The gamma-ray log (Plate 6A) is fairly uniform except for a peak indicating the presence of a somewhat thicker bed of black shale from 36.6 to 38.2 metres (120 to 125 ft). Palaeontological examination of samples from 38.2 and 42.7 metres (125 and 140 ft) suggests an Albian age, and the sample from 42.7 metres (140 ft) may indicate a slightly different environment of deposition (Ingram, 1970a).

#### *Gearle Siltstone*

The Gearle Siltstone was also encountered only in G.R. No. 1 bore. It is unconformably overlain by the Gascoyne alluvium and conformably overlies the Windalia Radiolarite. The unit is fairly distinctive both lithologically and on the gamma-ray log. It consists of black, very firm, slightly sandy and calcareous shale, interbedded with rare thin layers of chert near the top. The shale contains scattered rounded medium-sized quartz grains, rare phosphate nodules, and nodules of euhedral pyrite. Foraminifera are abundant from 13.5 to 18 metres (45 to 60 ft) and belemnites are numerous from 18 to 31 metres (60 to 102 ft). The upper part of the formation is slightly lighter coloured as a result of weathering, and an unknown thickness has been removed by erosion. The gamma-ray log peak (Plate 6A) occurring at the contact with the Gascoyne alluvium is considered to result from concentration of derived phosphatic nodules.

A sample from 26 metres (85 ft) was considered, from determinations of microplankton, to be of Albian age, probably from the Lower Gearle Siltstone (Ingram, 1970a).

#### *Tooolonga Calcilutite*

The Tooolonga Calcilutite was identified in nine bores (Table 1). The top of the formation was encountered in G.R. No. 2 where it is apparently conformably overlain by the Korojon Calcarenite, but the basal contact with the Winning Group was not intersected and its nature is unknown. It is olive green, blue-black to black where unweathered, and mottled grey, pink and yellow where weathered. Lithologically it consists of a slightly calcareous dense clayey siltstone or silty claystone with minor thin beds of fine to very fine, moderate to well sorted sandstone up to 4.3 metres (14 ft) thick. Brown ferruginous concretions and scattered rounded quartz grains occur throughout the formation. Rare glauconite grains and foraminifera are present in some sections. The formation is considered to be of Senonian age, on the evidence of microplankton (Backhouse, 1970; Ingram and Backhouse, 1970; Ingram, 1970b; Hooper, 1971b).

#### *Korojon Calcarenite*

The Korojon Calcarenite was encountered from 22.8 to 80.8 metres (75 to 265 ft) in G.R. No. 2. It was identified by its lithology and its conformable stratigraphic position above the lithologically distinctive and palaeontologically identified Tooolonga Calcilutite. The formation is unconformably

overlain by the Gascoyne alluvium and its true thickness is not known. It consists of white to yellow-brown calcilutite containing scattered fragments and prisms of *Inoceramus*. Up to 0.25 per cent of phosphate is present throughout. The age of the formation was not determined as no palaeontological work was done on any samples.

#### *Undifferentiated Cainozoic formations*

Five bores, downstream of Rocky Pool (Table 1), encountered sediments of uncertain age which overlie the Tooolonga Calcilutite with apparent unconformity, and are unconformably overlain by the Gascoyne alluvium. The sediments consist of yellow-brown, mottled green, grey and red, calcareous, probably bentonitic claystones with minor layers of silt, calcarenite, and hard white limestone. Some beds contain fragments of pelecypods, echinoid spines and foraminifers, and thin layers of glauconitic sand. The basal contact in PB 26/1250, 42.22 kilometres (26.2 miles) upstream of the river mouth, overlies slightly weathered Tooolonga Calcilutite, suggesting that the contact is an unconformity. The maximum thickness is unknown, but certainly exceeds 60 metres (197 ft) and probably increases toward the west because of the westerly dip.

Samples submitted for palaeontological examination contained only worn or unidentifiable fossil fragments of Cainozoic aspect (Hooper, 1971a, 1971b). On lithological grounds the beds probably belong to the Paleocene-Eocene Cardabia Group.

#### *Laterite*

A thin laterite up to 1.2 metres (4 ft) thick is developed on the surface of the unconformity which separates the Gascoyne alluvium from the underlying Mesozoic or Cainozoic rocks. It consists of well rounded dark red to yellow-brown lightly cemented pisoliths overlying a weathered zone which extends from 1.5 to 12.2 metres (5 to 40 ft) below the laterite. The weathered rocks are usually mottled pink, white or yellow-brown and may be slightly silicified. The laterite is evidently partly eroded as it was encountered in seven bores, while in the remainder it was absent and only weathered rocks were encountered. Exposures of the laterite showing its nature and evidence of partial erosion occur in the vicinity of Rocky Pool.

The age of the laterite can only be placed within fairly wide limits. If the undifferentiated Cainozoic rocks are the Cardabia Group then the laterite must be post-Eocene and if the Gascoyne alluvium is of Pleistocene age then the minimum age for the laterite could be Pliocene.

#### *Gascoyne alluvium*

The river flood-plain deposits are herein referred to informally as the Gascoyne alluvium. This was encountered in all bores, and ranges from about 3 metres (10 ft) thick at Rocky Pool to 57.8 metres (189 ft) in PB 22/720 (35.63 kilometres). The formation consists predominantly of yellow-brown to red-brown, mottled, poorly sorted clayey or sandy silt, with minor beds of poorly sorted sand, gravel and clay. It has been incised by the river which has deposited in its bed a medium to coarse sand which reaches a thickness of about 12 metres (40 ft).

The age of the flood-plain deposits is uncertain as no fossils or unoxidized strata samples suitable for palynological analysis were found. Condon (1968) accepted on global evidence that the post-Eocene laterite developed in the Carnarvon Basin ceased development and underwent dissection at about the end of the Pliocene. Further, the elevation of the base of the alluvium, rising from -43.2 metres (-142 ft) in bore 10/310 to 90 metres (295 ft) in G.R. No. 1 (Plate 5) suggests that the formation was deposited perhaps during the late Pleistocene rise of sea level. Hence despite the absence of definitive evidence the Gascoyne alluvium is considered to be of Pleistocene age.

## STRUCTURE

### FAULTING AND FOLDING

The regional dip of the Cretaceous rocks is 1 to 3° in a westerly direction (Condon, 1962, 1968). For this reason a correlation diagram with the bore logs projected onto a line bearing 280° is given in Plate 5. The diagram indicates that faults possibly occur between G.R. No. 1 and G.R. No. 2; between G.R. No. 2 and PB 48/3750; and that a fault or fold occurs at Rocky Pool. The faults are evidently post-Cretaceous but pre-Pleistocene, whereas the structure at Rocky Pool apparently involves the Gascoyne alluvium and is probably a post-Pleistocene feature.

### Rocky Pool "anticline"

The Toolonga Calcilutite which outcrops at Rocky Pool is the southern part of an arcuate, partially exposed outcrop, of low relief, which extends for about 65 kilometres (40 miles) north-eastward of the river (Condon, 1962). It has been incised 3 to 7.5 metres (10 to 25 ft) at Rocky Pool and has caused the channel of the Gascoyne River to be constricted from an average width of about 450 metres (1,500 ft) to 90 metres (300 ft). It also appears to affect the regional river gradient causing an apparent gradient of  $0.67 \times 10^{-3}$  (3.5 ft/mile) downstream of Rocky Pool and  $0.84 \times 10^{-3}$  (4.4 ft/mile) upstream, but the evidence is not unequivocal (Plate 6). Furthermore, the flood-plain deposits on either side of the structure are about 45 metres (150 ft) thick, whereas alluvium overlying the structure is 3 metres (10 ft) or less thick, gently folded, and resembles basal strata overlying the laterite to the east and west of the structure.

Hancock (1968) in a detailed study of the Rocky Pool area for a proposed dam site, concluded that the Toolonga Calcilutite formed the top of a broad, flat-topped asymmetrical anticline. However, the true nature of the structure is uncertain. Judged by the strike length of the structure, and the abrupt easterly contact exposed at Rocky Pool, the writer's opinion is that it is a fault of uncertain nature with the apparent folding resulting from drag in the thick, incompetent, Toolonga Calcilutite (Plate 5 inset A).

The structure may be interpreted either as a buried feature in the process of being exhumed or as an actively rising structure controlling sedimentation, and the grade and configuration of the river. The evidence is equivocal but the facts that the alluvium overlying the structure appears to be slightly folded; that the basal alluvium on and adjacent to the structure shows marked similarities suggesting displacement; and that the river appears to be actively downcutting through the structure despite raising of river base levels since the post-glacial rise in sea level, seem to indicate that the structure is an active or recently active feature.

## CONCLUSIONS

The drilling results have provided new information on the distribution, nature, thickness, and structure of the Cretaceous-Holocene formations in the Gascoyne sub-basin. The main conclusions are:

- (1) Correlation of the Permian and Cainozoic rocks is not certain, but the Cretaceous rocks can be fairly readily correlated with established stratigraphic units on lithology and palaeontology.
- (2) The structure of the westward-dipping Cretaceous rocks has probably been dislocated by pre-Pleistocene faults, and by an inferred post-Pleistocene fault which may still be active.
- (3) The structure at Rocky Pool resembles an anticline (Rocky Pool anticline) but is believed to be a drag fold.
- (4) The remnants of a post-Eocene laterite are preserved beneath inferred Pleistocene flood-plain deposits on the Coastal Plain.

### ACKNOWLEDGEMENTS

The writer wishes to thank Mr. E. Schenk, engineer, Public Works Department for making available data on the longitudinal section.

### REFERENCES

- Backhouse, J., 1970, Foraminifera from Gascoyne River No. 2 borehole: West. Australia Geol. Survey Pal. Rept. 22/1970 (unpublished).
- Condon, M. A., 1962, Kennedy Range, W.A.: Australia Bur. Mineral Resources 1:250,000 Geol. Series Explan. Notes, Sheet SG/50-1.
- 1968, The geology of the Carnarvon Basin, Western Australia: Part 3—Post-Permian stratigraphy, structure, economic geology: Australia Bur. Mineral Resources Bull. 77.
- Hancock, P. M., 1968, Geological investigations at Rocky Pool dam site, Gascoyne River: West. Australia Geol. Survey Rec. 1968/12 (unpublished).
- Hooper, K., 1971a, Two samples from Gascoyne River PB 26: West. Australia Geol. Survey Pal. Rept. 47/1971 (unpublished).
- 1971b, Three samples from Gascoyne River PB 26: West. Australia Geol. Survey Pal. Rept. 53/1971 (unpublished).
- Ingram, B. S. 1970a, Palynology of Gascoyne River (Mooka) No. 1 bore: West. Australia Geol. Survey Pal. Rept. 20/1970 (unpublished).
- 1970b, Palynology of some Gascoyne River investigation bores: West. Australia Geol. Survey Pal. Rept. 38/1970 (unpublished).
- Ingram, B. S., and Backhouse, J., 1970, Palaeontology of sludge samples from Gascoyne River O.A. O.D. No. 1: West. Australia Geol. Survey Pal. Rept. 26/1970 (unpublished).
- Playford, P. E., and Cope, R. N., 1971, The Phanerozoic stratigraphy of Western Australia. A correlation chart in two parts: West. Australia Geol. Survey Ann. Rept. 1970, p. 32-33.

# EARTHQUAKE HAZARD IN WESTERN AUSTRALIA

by F. R. Gordon

## PUBLIC PLANNING FOR EARTHQUAKES

### INTRODUCTION

Earthquakes have become a matter of public concern since the disaster at Meckering in October 1968, and since then the shakings from the Calingiri and the Canning Basin earthquakes have emphasized the need for public planning in Western Australia to take account of earthquake risk.

The planning of public policy has two distinct components:

- (1) community planning and development of earthquake protection prior to an earthquake disaster;

- (2) emergency operations during and immediately after a disaster and subsequent post-earthquake planning and reconstruction.

The extent of the post-earthquake assistance will depend to a large extent on the loss of life and the damage to property. Undoubtedly, pre-disaster planning would greatly increase the effectiveness of the post-earthquake aid and relief programme.

### PRE-EARTHQUAKE PLANNING

Pre-disaster planning will differ greatly from area to area and will reflect the probability of earthquake occurrence, as well as the special



hazards inherent in metropolitan areas and from foundation conditions. Planning should be directed towards two separate risk areas:

- (1) towns in the South West Seismic Zone (Fig. 8) and the separated towns of other well-defined seismic areas such as Marble Bar, Port Hedland and Broome;
- (2) metropolitan Perth.

Obviously the highest risk applies to the country towns of the South West Seismic Zone, as on present knowledge damage to Perth would eventuate only if a major earthquake occurred within 160 kilometres (100 miles) of the city, while a damaging earthquake could occur anywhere in the South West Seismic Zone at any time. A survey of the earthquake resistance of existing structures in towns in the South West Seismic Zone is necessary, with special emphasis on the larger and older towns like York, which have already sustained some damage from seismic shaking. Detailed recommendations for the appraisal of existing conditions in building in the seismic zone are contained in a later section. The other main element of earthquake planning is the provision of a seismic building code. The basic need is to ensure at least *earthquake-resistant* construction which protects life; *earthquake-proof* construction is not considered economically justified.

#### ORGANIZED AND RATIONAL PREPARATION

Most of the State is liable to seismic shaking, and some areas must be classed as active seismic zones. At present it is not possible to predict accurately the occurrence of earthquakes in time and space, but measures can be taken to minimize their effects on life and property. Even if accurate prediction were achieved, the importance of earthquake-resistant construction would not be reduced.

The most important aspect of the hazard is the safety of human life; the control of property damage being a secondary consideration. As long as a building remains standing and people are safe inside and outside of it, then structural damage may be allowed. However, the degree of permissible damage to a structure is a serious economic cost-benefit problem.

### HOW EARTHQUAKES CAUSE DAMAGE

#### GENERAL CONDITIONS OF DAMAGE

Wallace (1968) has shown that earthquake damage is usually manifest in four separate forms: (1) fault displacement, (2) seismic shaking, (3) ground failure, and (4) tectonic warping. All these causes of damage are affected by the following variables: (a) magnitude of the earthquake, (b) focal depth, (c) distance of structure from source, (d) extent and magnitude of faulting, and (e) intensity and duration of shaking.

#### FAULT DISPLACEMENT AND GROUND BREAKAGE

This type of damage occurs when a structure is located astride the actual plane of movement and is torn apart by violent differential action. No matter how well designed a structure might be, if the amount or type of faulting is not anticipated, the structure will fail if movement occurs during a strong earthquake. But as movement is generally confined to a narrow zone during any earthquake, a structure directly on the trace of a moving fault may be torn in half, while another located perhaps 10 metres (30 ft) away may be undamaged. Fault displacement in the South West Seismic Zone may accompany earthquakes of magnitude 6 or more.

Considerable damage may result from tension openings or minor fault zones developed at the same time as the main fault, or from subsequent aftershocks.

#### SEISMIC SHAKING

Damage to structures by shaking occurs when earthquake vibrations are transmitted from the ground to the structure. Cluff (1968) lists the main variables that determine the extent of damage as type of ground, earthquake-resistant design, and

quality of materials and construction. Experience gained from the Meckering earthquake has shown that other factors may be added, such as the relative orientations of source and structure, the location of the structure relative to block movement, and the geology of the area between source and structure.

If other factors are equal, damage resulting from a major earthquake occurring on a fault will decrease with distance. However, the most important factor is the type of foundation soil on which the structure rests, although the type of structure and its design and construction are also of importance. If a structure close to a fault zone is designed and constructed to be earthquake resistant, and does not actually straddle the fault zone, it may be comparatively safer than a similar structure several miles away from the fault, but on poor ground, or not properly designed and constructed to resist shaking.

The earth waves which cause shaking are different in different materials. In general, solid rock such as granite carries only short-period earthquake waves which cause a rippling motion at the surface. At the opposite extreme, deep uncemented saturated alluvium can support only long-period waves which result in a lurching motion at the surface. Structures built on such material are likely to be subjected to much more violent shaking than those on hard rock.

#### GROUND FAILURE

Damage may be caused by shaking of foundation soil and may take three possible forms: landsliding, settlement, or liquefaction. In addition to the general variables already mentioned, two other important factors are: (a) the degree of saturation of the soil, and hence the position of the water table, and (b) the site geology. Each form of ground failure has further determinants, and minor geological features of the site are of considerable importance.

A recent study by Seed (1968) of landsliding during earthquakes indicates that slides are invariably started by the liquefaction of saturated sandy soils which are already in a loose to fairly loose condition. The earthquakes studied varied in magnitude from 5.5 to 8.5, at epicentral distances ranging from several kilometres to hundreds of kilometres. Landsliding reactivated in the metropolitan area by the Meckering seismic shaking is detailed later in this text.

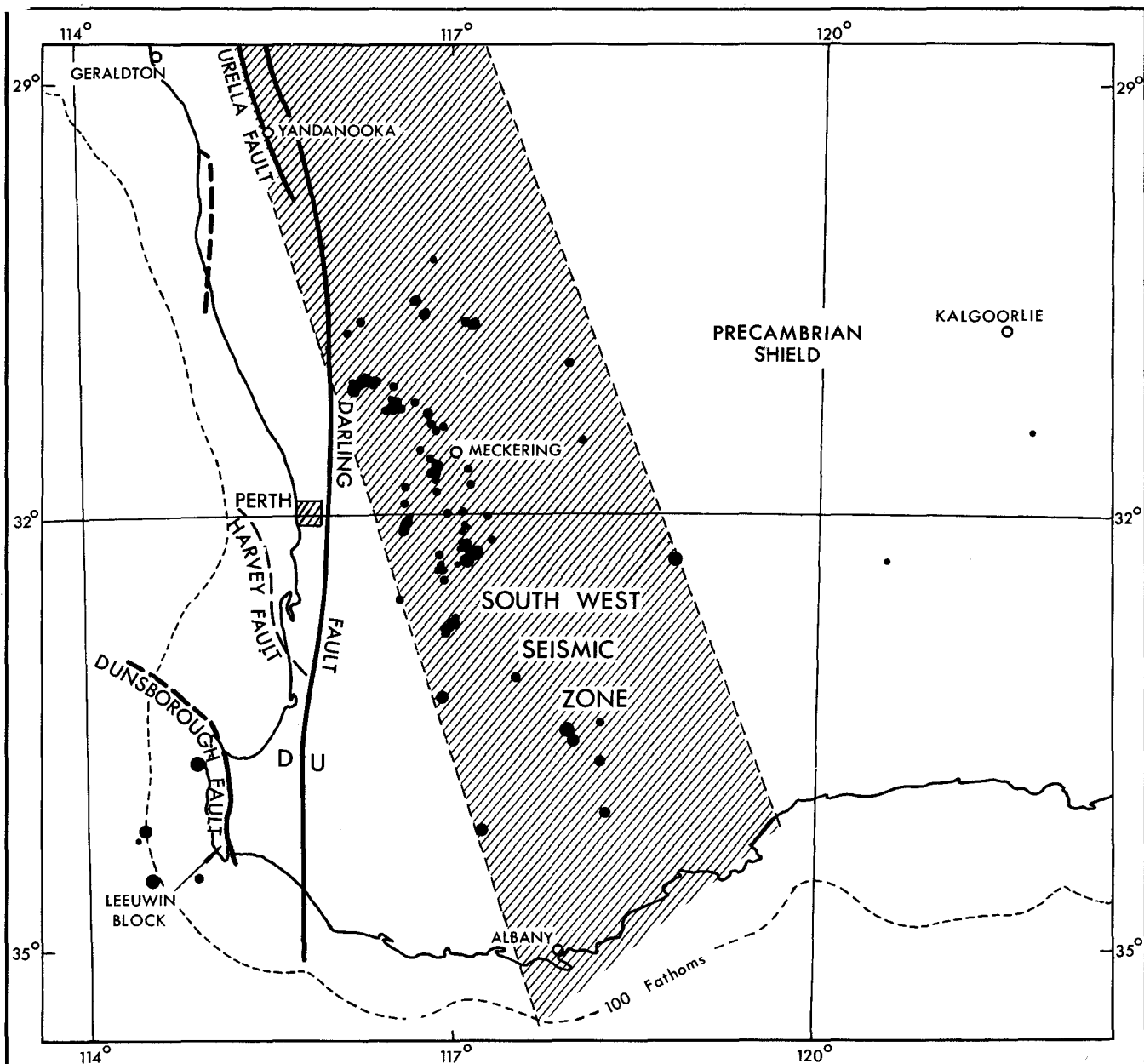
### EARTHQUAKE RISK ZONING FOR WESTERN AUSTRALIA

A *seismic zone* is a region within which there is an obvious grouping of earthquake epicentres. The South West Seismic Zone of Western Australia (Doyle, 1971) is a belt about 60 kilometres (37 miles) wide and 550 kilometres (342 miles) long in which, during the period from August 1959 to June 1965, 205 earthquake epicentres were located (Everingham, 1968). In the same period, only 5 epicentres were recorded elsewhere in the State.

An *earthquake risk zone* is a region throughout which there is an equal level of risk from earthquake effects.

A *tectonic belt*, as used in this report, takes into account the historical record of earthquakes, the scatter of recorded epicentres, evidence of ground disturbance in reasonably recent times and the global tectonic pattern. "Tectonic" means structural, and tectonic earthquakes are associated with faulting or other structural processes.

Earthquake *magnitude* is a rating of the total energy released by an earthquake. The magnitude as originally defined by Richter (1958) is the logarithm of the maximum recorded amplitude shown on a standard type of seismograph at a distance of 100 kilometres (62 miles) from the epicentre. Because the scale is logarithmic, every upward step of one magnitude unit corresponds to a 10-fold increase of recorded amplitude. The upper limit of magnitude, set by the strength of the rock, is about 8½. A one unit increase in magnitude also corresponds roughly to a 30-fold



EPICENTRAL DATA FROM EVERINGHAM AND GREGSON, 1969

**SEISMIC ZONE AND GEOLOGICAL STRUCTURE**  
 (KNOWN EARTHQUAKE EPICENTRES OCT. 1959 – DEC. 1967)

REFERENCE

- EPICENTRE  $M_L < 3.0$
- EPICENTRE  $M_L 3.0$  to  $3.9$
- EPICENTRE  $M_L 4.0$  to  $4.9$
- FAULT
- - - INFERRED FAULT

SCALE

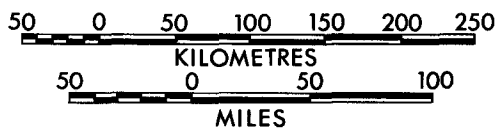


Figure 8.

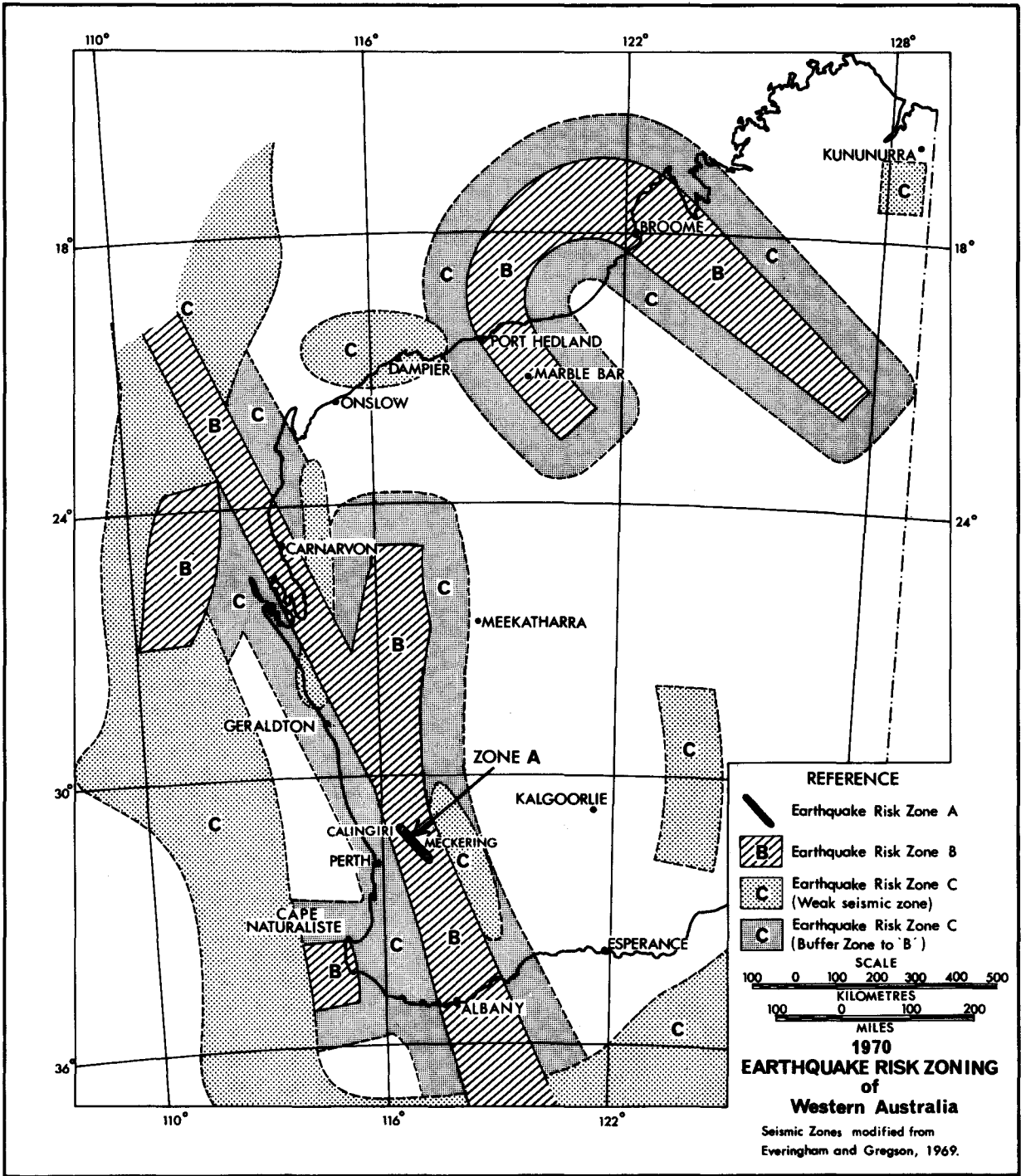


Figure 9.

increase in energy, and a two unit increase in magnitude, e.g. a unit increase from 6 to 8 leads to a 30 times 30 (or 900-fold) increase in energy.

*Intensity* is a measure of the degree of shaking at a specified place. Intensity ratings are non-instrumental and rely on human observation and interpretation. The ratings are assigned by an experienced observer using a descriptive scale. The Modified Mercalli (MM) scale has grades indicated by Roman numerals from I to XII.

For every earthquake there is only one magnitude, but the local intensities vary widely, according to the position and the judgment of different observers. As each location experiences an intensity measured by the earthquake effects at that location, a line called an *isoseismal line* can be drawn to separate areas experiencing different intensities. They were originally drawn as curves connecting localities where equal intensity was observed in a given earthquake.

#### EARTHQUAKE RISK ZONING, AND SEISMIC CODES

Western Australia has not suffered uniformly from the effects of earthquakes. Some areas have had earthquakes more frequently than others, and some areas have had virtually none. An earthquake risk zoning scheme is an attempt to take account of variations in this regional seismicity. Earthquake risk zoning has been used in many parts of the world, and the basic principles are the same everywhere. Zone boundaries are defined by taking into account historical records of past damaging earthquakes, the scatter of recorded epicentres, the destructive range of earthquake shaking, evidence of ground disturbance in reasonably recent times, and general geological considerations of tectonic activity.

These risk zones are defined in terms of relative frequency of destruction from earthquakes, not of absolute liability to destruction. Schemes of zoning have been defined in, for example, the United States, Japan, in Turkmen in the U.S.S.R., and in New Zealand, the object of all these schemes being to delineate areas of equal earthquake risk.

Once zoning has been achieved, basic shear coefficients necessary to strengthen buildings are applied to each zone by structural engineers and engineering seismologists in the form of a seismic code. Almost every country has its own basic coefficients, two of the best known being the New Zealand Code and the S.E.A.O.C. (Structural Engineers' Association of California) Code.

The fundamental concern of any seismic code must be to endeavour to remove the hazard to life as far as this is practicable. A secondary consideration is to minimize damage, both structural and non-structural, for earthquakes of moderate intensities, but a considerable amount of non-structural damage and of appreciable plastic strain to basic structures will occur in the event of major earthquakes (New Zealand Standards Institute, 1965).

A criticism that has been levelled at the drawing of zone boundaries is that it is an improper task to attempt to limit the possible areas of earthquake occurrence. This approach means that all areas of the State are regarded as seismic until they are proved otherwise, in which case all buildings in the State would have to be designed to resist damaging earthquakes and the cost would be prohibitive.

At the opposite end of the scale is the attitude that "Meckering has had its earthquake and Perth has largely escaped, so what is there to worry about?". However, as Richter (1958) points out, there is little to justify the assumption that the strongest shaking known to have affected a given point in the past will never be exceeded. Eiby (1968) stated that "the alarmists and the complacent are equally to be condemned, but it should be noted that several of the worst disasters in recent years have stricken places that believed themselves to be beyond the active zones or in marginal zones where the intensity would be less".

Each new earthquake causes a revision of the estimates of seismicity, and may cause earthquake risk zones to be altered and seismic codes

to be increased. The risks are always increased by additional records and knowledge, never decreased. However, there are certain districts in Western Australia that are more liable to damaging earthquakes than others and this forms the basis of the present zonation, based on knowledge as at November, 1970. As the principles behind the New Zealand method of zoning are clearly defined (Clark and others, 1965) and are capable of modification for Western Australian conditions, these principles can be applied to Western Australia. Any other system of zoning in current use would give similar results.

#### EARTHQUAKE RISK ZONING IN NEW ZEALAND

In New Zealand three zones have been defined to cover the situation in which some regions have been subjected to earthquakes in recent times, with a wide variety of intensities, while others rarely experience earthquakes of even minor intensity. This pattern is reasonably consistent with the geological record of ground disturbance in relatively recent times.

The New Zealand Code coefficients, applied to Zones A, B and C for public buildings, are deemed adequate for earthquake intensities of Modified Mercalli (MM) 9, (MM) 8½ and (MM) 8 respectively and those for private buildings for intensities (MM) 8½, (MM) 8 and (MM) 7½. The New Zealand version of the Modified Mercalli felt intensity scale (Eiby, 1966) is given in Appendix 2, as this version is a considerable clarification of the old scale, and the essential differences between the degrees can be better appreciated.

Zone A has been delineated to comfortably include all regions known to have suffered more than minor seismic damage, all known epicentres of "normal" earthquakes of magnitude greater than 6, and all known indications of earth disturbances likely to be of earthquake origin, within about the last 10,000 years.

An earthquake can be destructive with a magnitude as low as 6, depending upon the depth of the focus and the nature of the foundation materials.

The active tectonic belt between Meckering, Calingiri and Yerecoin must be classified in Zone A, as earthquakes have occurred on seven occasions since 1949: at Walebing, 1949; Bolgart, 1952; Calingiri, 1955; Yerecoin, 1955; Carani, 1963; Meckering, 1968 and Calingiri, 1970.

Although the Meeberrie earthquake was the largest recorded in historic times on the Australian continent, the focal depth of 70 kilometres (44 miles) means that damaging intensities were not manifest. For this reason the Meeberrie Zone is not classified in the destructive damage Zone A.

Zone B is a buffer zone in which history indicates that moderate damage may result from earthquakes of intermediate magnitude, either within the lifetime of a building or from the distant effects of earthquakes in Zone A.

By New Zealand standards, Zone B is considered less liable to severe earthquakes, but in Western Australia this supposition may not apply.

In the New Zealand rating, "B" is a median zone, half the width of Zone A applied on either side of Zone A. This means that if the New Zealand pattern were applied then the buffer zone B would be about 50 kilometres (31 miles) wide, surrounding the active Meckering-Calingiri-Yerecoin Zone.

However, the active South West Seismic Zone poses almost as grave a risk as the destructive Zone A areas, because the release of strain in the earthquake areas can only mean that strain is accumulating in adjacent areas of the seismic zone. The zone of seismicity and of ground disturbance thus does not meet the requirements of defined Zone A and yet is potentially dangerous. In the Western Australian zoning it must be considered to be the core of Zone B, rather than to be classed with Zone A or Zone C. The Meckering-Calingiri-Yerecoin area may now have been relieved of strain, and adjacent areas may be sites of future activity.

The Balardon Tectonic Belt extends from the south coast near Albany through to the northwest coast. Its maximum width, as indicated by arcuate fault structures, is 100 kilometres (62 miles) and this neatly covers the active South West Seismic Zone which is about 50 kilometres (31 miles) wide, and also covers the fringe zones on either side, of half this width.

The Port Hedland-Marble Bar Seismic Zone is not well defined, but is quite active, with at least four earthquakes recorded of over magnitude 5. It must also be considered of sufficient potential activity to warrant classification in risk Zone B.

Similar considerations apply to the Broome-Canning Basin Seismic Zone. Some large earthquakes (one of magnitude greater than 6.0) have been recorded offshore northwest of Broome, and another of magnitude greater than 5.0 has occurred onshore, east of Broome. The 1970 Canning Basin earthquake, 600 kilometres (380 miles) north-east of Broome, of magnitude 6.5, is tentatively included in this seismic zone. Until further seismological installations allow better definition and until geological evidence is available, the Broome-Canning Basin Seismic Zone is considered to be sufficiently active to be classified as Zone B.

Of the other seismic zones in the State, the most interesting, in view of its proximity to the Ord River Dam is the Turkey Creek Zone. With no major earthquakes recorded, it is considered as being of weak or minor seismicity (Zone C), but further information may change this rating. The only town of any size is Kununurra, 60 kilometres (38 miles) north of Argyle Downs Homestead, the epicentre of a small magnitude earthquake in 1968. Seismic coefficients have been incorporated in the design of the Ord River Dam, 20 kilometres (12 miles) south of this epicentre.

Zone C has been conservatively drawn to include those regions which at the most have suffered trifling damage to the poorest class of non-earthquake-resistant buildings, and which are free of epicentres of other than minor magnitude and of ground disturbance in reasonably recent times.

By New Zealand standards this is less liable to severe earthquakes, say 33 per cent risk as compared with 100 per cent for Zone A, and 67 per cent for Zone B. In Figure 9 it has been drawn as a 100-kilometre (62 mile) margin to Zone B, and would act as a buffer to any major earthquake. Seismic shaking is propagated more readily to the east than to the west, and for this reason Zone C is drawn on the eastern margin of Zone B. As the tectonic zone is flanked to the west by the Perth sedimentary basin, the effects of the lesser western propagation of shaking are nullified by the poor foundation materials. Zone C is therefore also drawn as being 100 kilometres (62 miles) wide on the western margin of Zone B.

The two B zones in the north of the State—Port Hedland-Marble Bar and Broome-Canning Basin—have also been enclosed in a buffer zone, 100 kilometres (62 miles) wide, designated Zone C.

Elsewhere in the State, zones of weak or minor seismicity from which no moderate or large earthquakes have been recorded, or from which weak seismic effects but no damage have been reported, are regarded as belonging to Zone C until further knowledge revises the classification. There are several areas where the two types of C-zone classifications overlap.

A considerable area of the interior of the State remains unzoned. This is not to say that it is declared aseismic, and is considered free from the possibility of earthquake damage. It is merely unzoned in the sense that earthquakes have not yet been known to occur in the area.

#### THE SEISMIC RECORD

The instrumental record of Western Australian earthquakes was not satisfactory until 1959. A period of 11 years of good instrumental records is on its own inadequate to justify detailed seismic zoning or to be used as a basis for the calculation

of risk factors. In America and Japan, a total of 70 years of instrumental recording is considered inadequate for the same task.

The Perth metropolitan area was first settled in 1829, but the historical record is incomplete from 1829 to 1880, and the seismological and historical records do not provide an adequate basis for estimating the future seismicity of the State. The only practical approach is to study the historic seismic activity in a region, to temper this information with geological knowledge of past events, and then to judge the future earthquake potential.

#### SEISMIC ZONES

Everingham and Gregson (1970) presented data derived from epicentres, outlining 14 seismic zones in or marginal to Western Australia. Of these, seven were classed as well defined (Fig. 9). The best known zone, referred to by Doyle (1971) as the South West Seismic Zone, extends from Watheroo to Ongerup, a distance of 555 kilometres (345 miles). Of 205 recorded in the period 1959 to 1965, only three epicentres lie outside a zone 60 kilometres (37 miles) wide that trends at 335°. The other well-defined zones are:

Zone 2 (Meeberrie) is a northerly trending zone, 320 kilometres (200 miles) long and 160 kilometres (100 miles) wide, including, near the centre of its eastern margin, the epicentral region of the 1941 Meeberrie earthquake of magnitude 7.5, the greatest recorded earthquake shock experienced in Australia.

Zone 3 (Naturaliste-Leeuwin) is a zone 160 kilometres (100 miles) long and 130 kilometres (80 miles) wide which has as its eastern margin the eastern edge of the Leeuwin Block, which is itself defined by the Dunsborough Fault.

Zone 4 (Indian Ocean) is a north-northeasterly trending zone about 450 kilometres (280 miles) long and 160 kilometres (100 miles) wide that has its centre 240 kilometres (150 miles) west-southwest of Carnarvon.

Zone 5 (Marble Bar-Port Hedland) includes Marble Bar near its centre and Port Hedland on its western margin. The zone trends northwesterly and is about 320 kilometres (200 miles) long and 125 kilometres (80 miles) wide. Everingham (1968) considered this the most active zone in Australia.

Zone 6 (Broome) trends northwesterly and includes Broome near its southwestern border. The zone is about 200 kilometres (120 miles) wide and 350 kilometres (220 miles) long on land, and it is continued by Everingham and Gregson in the form of a semi-circle to join the Marble Bar-Port Hedland Zone. The Canning Basin earthquake of the 24th of March, 1970, has caused this zone to be extended to the southeast.

Zone 7 (Turkey Creek) has been drawn as a northerly trending zone, 125 kilometres (80 miles) long and 160 kilometres (70 miles) wide, centred on Turkey Creek.

The other seven zones are ill defined and are of weak seismicity (Fig. 9).

#### GLOBAL SEISMICITY

The United States Coast and Geodetic Survey has published a map showing the world-wide distribution of all earthquake epicentres for the period 1961 through 1967 (Baraganzi and Dorman, 1968). The outlines of the various plates as defined by the modern tectonic concepts are clearly marked (Fig. 10), and a series of well-defined lines of seismicity that radiate from near the centre of the Indian Ocean is of present importance. These features suggest a breaking up of the Indian Plate of which Australia is a part. One line trends through Shark Bay and Meckering to the south-southeast, to re-enter the south boundary of the Indian Plate at lat. 128° S, long. 50° E.

This global seismic line includes the South West Seismic Zone, and extends it considerably. From a consideration of the mechanism of the Meckering earthquake, Gordon and Wellman (1971) proposed an active shear zone coinciding with the seismic

zone, and suggested that movement on this shear caused the compression of the Meckering cap, followed by shearing, release and expansion which gave the spectacular arcuate faulting around Meckering. It is clear that the action could take place at any position along this global line of seismicity, and both the South West Seismic Zone and the Indian Ocean Zone are part of the same tectonic feature (Fig. 11). It is proposed to name this important seismic lineament the Eendracht Line.

#### SEISMIC CONSIDERATIONS IN ASSESSING RISK

Larger earthquakes are probable in the areas where small ones are frequent. This point was forcibly proven for Western Australia by a magnitude 6.5 earthquake on the 24th of March, 1970, its epicentre being about 1,500 kilometres (950 miles) northeast of Perth, 480 kilometres (300 miles) south of Halls Creek and 160 kilometres (100 miles) west of the Northern Territory border (Fig. 11). There are no previous records of seismic activity in this area, so a fundamental concept of earthquake risk zoning in this State is the assumption that the South West Seismic Zone is a most likely area for a large earthquake, but that apparently inactive portions of the zone or seismically quiet areas between this zone and the Meeberrie Zone must also be suspect.

Each seismic zone has a characteristic depth of epicentres. On the evidence to date, the South West Seismic Zone is one of shallow epicentres and the seismic effects are much stronger than those emanating from earthquakes with deep-seated epicentres such as the Meeberrie Zone.

#### DAMAGE RECORDS

A record of felt effects and of damage to population centres for the period 1904 to 1965 has been compiled by Everingham (1968). His map is reproduced unaltered (Fig. 12) and shows that damage and seismic effects from the South West Seismic Zone extend from Walebing to Albany. On the same 340° trend there are reports of activity or damage in the vicinity of Perenjori and Morawa, and the Meeberrie damage is located on a line swinging slightly inland, and trending northerly.

A zone 50 kilometres (31 miles) wide and 785 kilometres (490 miles) long encloses most of the major centres of felt effects and damage. There are well-defined fringe zones at Kununoppin-Mukinbudin, and at Kukerin-South Pingrup. Separate zones that are clearly defined from seismic disturbances are seismic zones nos. 3, 5, 6 and 7, and outside of these almost all the other felt effects and damage reports are in the seven other minor zones. The exceptions are the coastal towns of Geraldton, Onslow and Wyndham and the inland mining towns of Cue, Leonora, Kalgoorlie, Kanowna and Boulder. The damaging shaking recorded in the mining areas is almost certainly caused by rock bursts in the deep mines, and a seismograph installed at Kalgoorlie has confirmed that the foci are located in underground workings. The mining towns, including the new nickel mining centres, should be designed to resist shaking propagated locally.

Everingham's record is supplemented by a map and a list of Western Australian earthquakes dating from 1849 to 1926, as compiled by the Central Weather Bureau in 1929. According to the latter list, several centres outside of the well-defined seismic areas experienced earthquakes, including Eucla, Eyre and Israelite Bay on the south coast and Peak Hill in the North West Division. In May 1916, a distinct earthquake shock was felt between Ravensthorpe and Hopetoun, but no damage was done. There is a possibility that the occurrence was caused by a rock burst underground, or it may mean that the Kukerin-South Pingrup fringe zone of minor seismicity has to be extended to the east.

On four occasions in the period 1849 to 1926, Perth was shaken by earth tremors which were not recorded from other centres. Houses near Wyening, 110 kilometres (70 miles) northeast of Perth, have been damaged six times since 1949.

However, earthquake centres may be expected to migrate away from the recently active areas as stress is released, and although Meckering may be free from further large earthquakes, areas either to the north, south or east may be even now subjected to increasing stress which would eventually lead to an earth movement and seismic shaking.

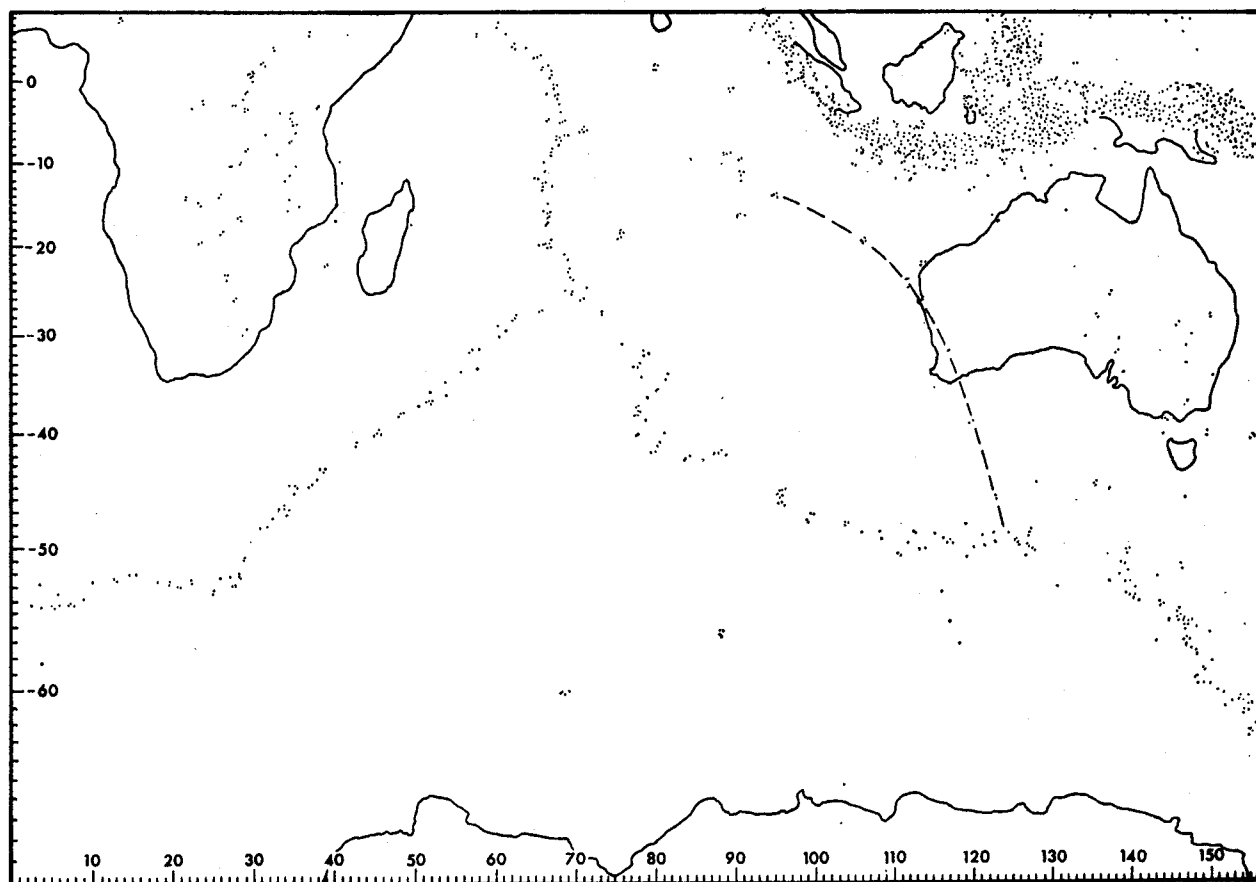


Figure 10. Distribution of earthquake epicentres for the period 1961 through 1967 as reported by U.S. Coast and Geodetic Survey (after Baraganzi and Dorman 1968) for the Indian Ocean Region. Eendracht Line is dashed.

12398

## THE GEOLOGICAL RECORD OF TECTONIC ACTIVITY

### METHODS

Two geological methods are employed in assessing earthquake risk in terms of the probability of destruction within a given period of time:

- (1) Earthquake risk zones exist within which earthquakes are to be expected because of their past occurrence. The Calingiri and Meckering earthquakes were accompanied by measurable tectonic deformation revealed by faulting, warping and tilting of the earth surface.
- (2) The distance from the earthquake epicentre to the edge of destructive influence can be decided by the shape of recorded isoseismals and other intensity data. The isoseismal shapes have to be interpreted in terms of rock types and geological structure.

### FAULTING AND MORPHOLOGY

The remarkable arcuate scarps which appeared after the earthquakes near Meckering and Calingiri were both low angle reverse faults, or thrusts caused by compression. Geological investigations showed that previous movement had occurred in the past on the Meckering and Calingiri faults. Under conditions of normal erosion, an arcuate fault would normally produce arcuate stream courses around the scarp. Long north-north-westerly directed stream lineaments have been found, and also a remarkable series of arcuate, in places almost circular, geological structures extending on a north-northwest trend intermittently from the south coast near Bremer Bay to Perenjori. Similar structures were noted north of Paynes Find and elsewhere. They are certainly related to the geology and almost certainly related to faulting, forming an interlocking or concentric pattern.

A field examination of one of these structures is needed to determine its true geological significance.

Of the two intersecting tectonic belts outlined by the presence of ground disturbance, the one trending south-southeast seems the most important. It completely encloses and overlaps the South West Seismic Zone and is itself part of the Eendracht seismic line, trending across the southwestern corner of the State. It is a belt of frequent tectonic deformation and of major earthquake epicentres for which the name Balardon Tectonic Belt is proposed (Fig. 11). No indications are at present available of the age of the arcuate faulting found within the zone, except for the reactivations at Meckering and at Calingiri.

### THE DARLING FAULT

As one of the major tectonic fractures on the surface of the globe, attention has naturally been focussed on the Darling Fault as a possible source of earthquakes. The Darling Fault is over 970 kilometres (600 miles) long and the west side is displaced vertically downward about 10,700 metres (35,000 ft). The fault is generally considered to be normal, but the compression faulting at Meckering and Calingiri raises the possibility that the fault could be reverse or strike slip. A major negative gravity anomaly exists over the Perth sedimentary basin to the west of the fault scarp, and the region is isostatically unbalanced. Only one epicentre in the period from 1959 to 1970 has been positioned on the line of the fault, this causing a very low magnitude earthquake in the Gosnells area, which could easily have been caused by an explosive charge.

There is no evidence of displacement of the Cretaceous rocks in the Bullsbrook area, where they overlap the Archaean granites. Such structure as is apparent may be the result of compaction after deposition. From other evidence, Playford (1967) has affirmed that movement does not appear to have taken place anywhere along the fault during the last million years.

There are some features of the scarp form in the vicinity of Perth that appear to indicate much later movement than is apparent elsewhere. The scarp looks extremely fresh and there are features of stream alignment which may possibly indicate movement since the establishment of the present general sea level, that is, in post-Pleistocene times.

Many major streams on the plateau to the eastward flow in a northwesterly direction. Their consequent courses down the scarp are generally westerly, at right angles to the scarp. When the streams reach the coastal plain many of the trends become southwesterly. In addition to this major swing of direction, individual stream courses show sudden small directional changes or kinks, on a general northerly line about 2.4 kilometres (1.5 miles) west of the toe of the present scarp. The "kinks" are mainly directed northward in the vicinity of Perth.

Both the major swing in stream direction to the southwest and the line of breaks in the stream channels may be the result of late movement on the Darling Fault. Further work should be done on the stream-channel morphology and on the correlation of river terraces to determine rates of elevation or depression of the Darling Range.

The Darling Fault must be considered inactive on the evidence available, but because of its size and proximity to Perth, any seismic activity along its length should be treated with the greatest respect.

### THE URELLA FAULT

The Urella Fault is over 240 kilometres (150 miles) long, and trends north-northwest, parallel to the Darling Fault in the northern part of the Perth Basin. It is considered to be a normal fault with a possible throw of over 6,000 metres (20,000 ft), the date of last known activity being in Lower Cretaceous times.

Although not known to be active, the fault is exactly on line with the projected northerly position of the sinistral shear activating the South West Seismic Zone, and both are included in the Eendracht Line along which there may be discontinuous areas of activity. In the South West Seismic Zone the activity takes the form of gradual sinistral shearing of a zone consisting of several faults.

### THE DUNSBOROUGH FAULT

Earthquake records for the Perth metropolitan area show a surprising distribution of activity. From 1894 to 1925, six weak and two strong earthquakes were noticed in Perth and nowhere else, whereas strongly felt events in the adjacent seismic zones were felt in Perth also. Possibly some of the Perth occurrences originated in the South West Seismic Zone, but the centre of severest felt intensity were not recorded because of lack of communications. The other possible explanation is that the earthquakes were not centred in the South West Seismic Zone, but originated in an active zone from where the effects were felt in Perth and not elsewhere. One possible origin of the shocks is on the line of the Dunsborough Fault, with submarine epicentres west of Fremantle, as recent epicentres have been recorded from this well-defined zone. It is hoped that echo-sounding traverses and magnetic profiles recorded by oceanographic ships will be available in the near future, as a feature closely resembling a fault scarp has been tentatively recorded from a position about 160 kilometres (100 miles) west of Fremantle, coinciding with the position of a strong magnetic anomaly recorded by the USS *Eltanin* in 1970.

### RECENT FAULTING

Recent faulting has not so far been recorded from anywhere outside of the South West Seismic Zone, and some of the larger recorded shocks have occurred in areas where faulting would not normally be seen—in the Canning desert, or offshore.

RELATIONSHIP OF TECTONIC BELT, SEISMIC ZONES  
AND GLOBAL SEISMICITY

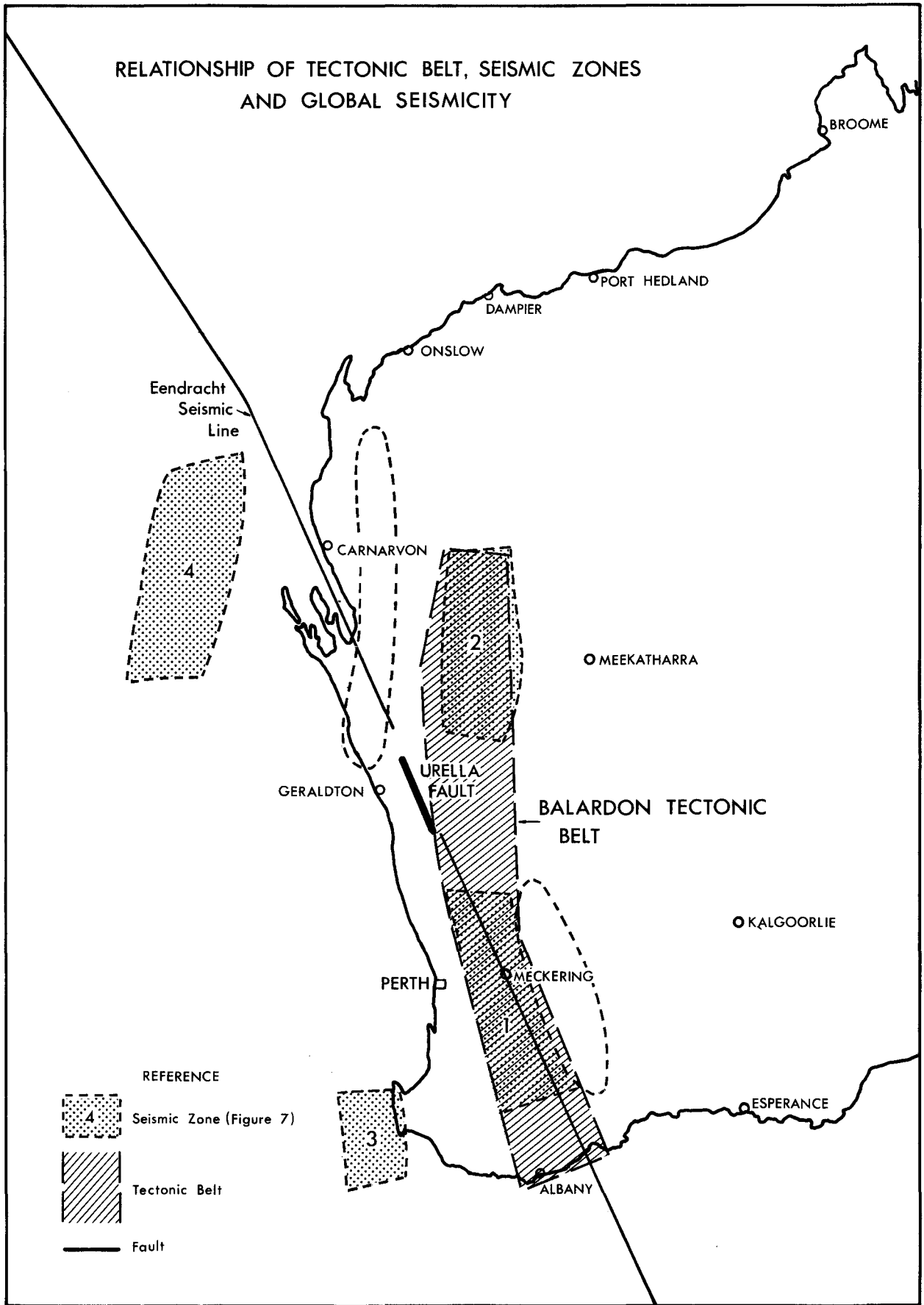


Figure 11.



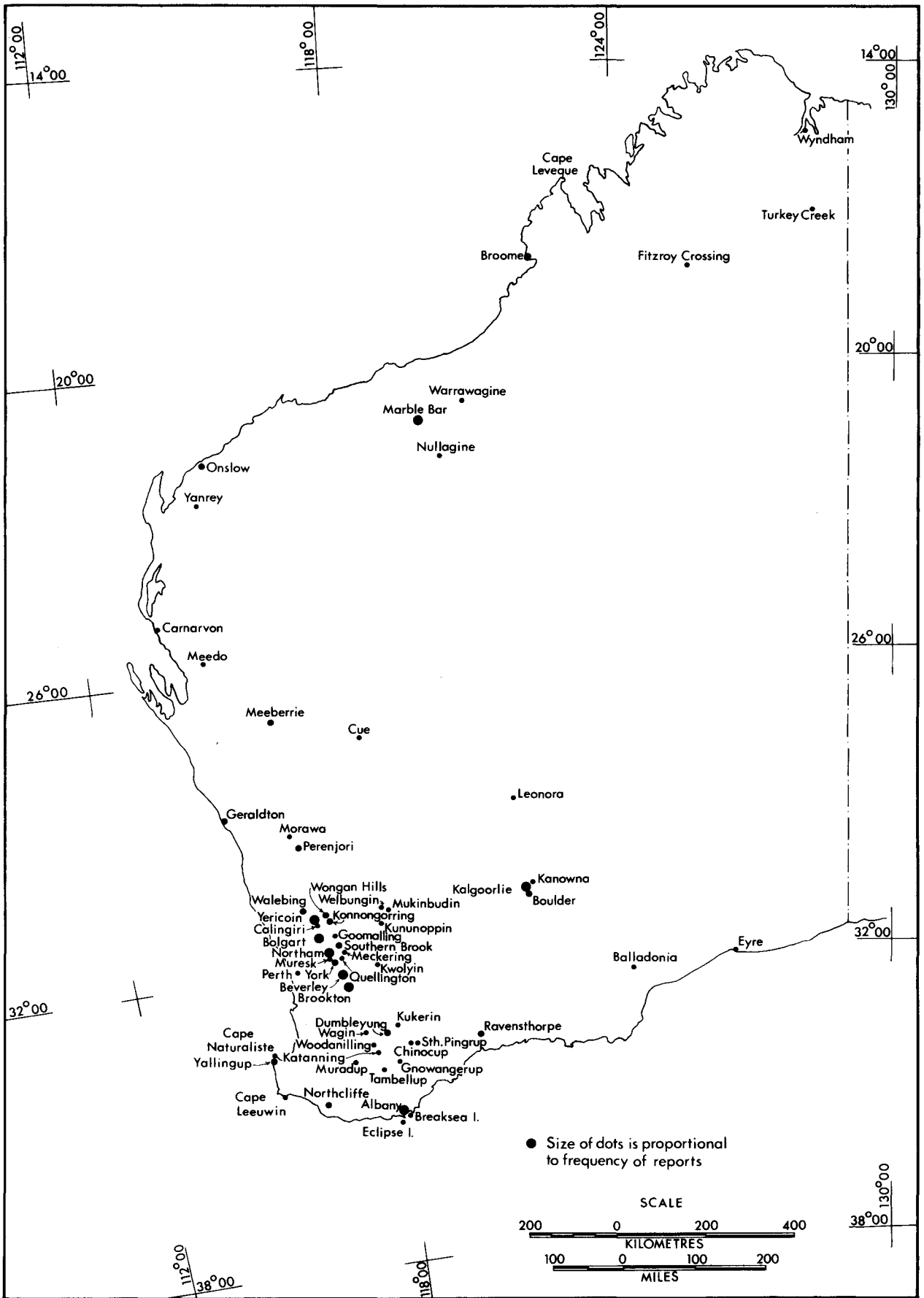


Figure 12. Record of damage and earthquake effects to population centres from 1904 to 1965 (after I. B. Everingham 1968. Seismicity of Western Australia, plate 3). Size of dots is proportional to frequency of reports. 12399

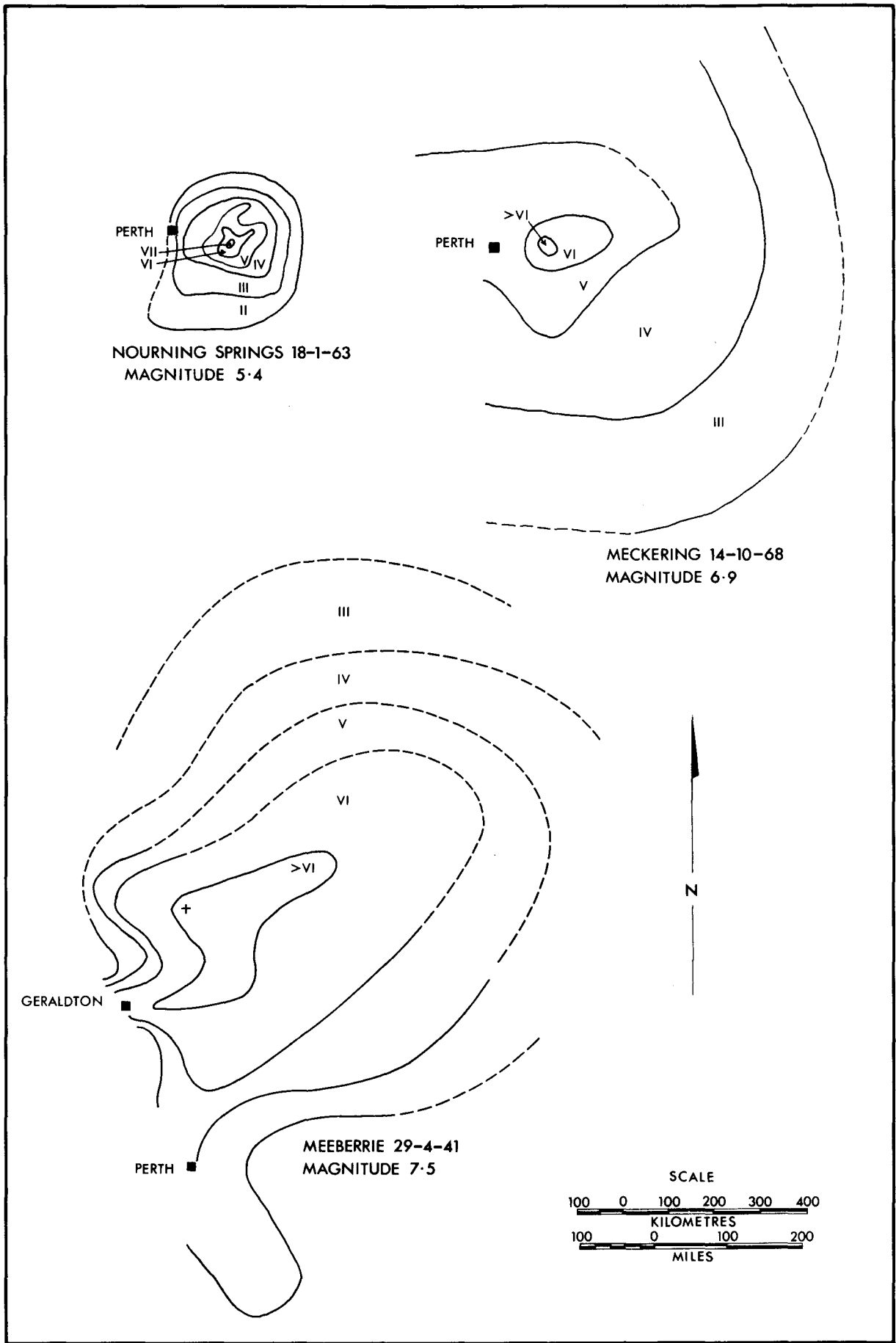


Figure 13. Isoseismal maps of Western Australian earthquakes.

A sinuous crack over 20 metres (60 ft) long and open up to 6 centimetres (2.5 in) was found at right angles to the bank of the Murchison River, southeast of Meeberrie Station, after the 1941 Meeberrie earthquake. This feature was probably caused by seismic shaking, but it is quite possible that primary ground breakage farther north was not discovered. The epicentre of the magnitude 7.5 earthquake was certainly to the north of Meeberrie homestead and a fault scarp may yet be found in the rugged Mount Narryer area 140 kilometres (90 miles) to the north, where an arcuate structure shows clearly on air-photo mosaics.

The Yerecoin earthquake in 1955 and the Bolgart earthquake in 1952 were almost certainly of magnitude 6 or greater, and could easily have been accompanied by faulting, as yet undetected.

#### ISOSEISMAL MAPS AND DESTRUCTIVE EFFECTS

Isoseismal maps show that destructive effects extend for unequal distances in different directions. A major influence on the shape of the isoseismals is the nature of the ground at the place from which reports are received. At Meckering, values of MMIV were recorded on the Darling Range and scarp, yet on the Perth coastal plain farther west, values as high as MMVI were recorded. The felt intensities reflect locally bad ground conditions for which due allowance must be made in assessing earthquake risk.

The regional trend of geological structure has a strong influence on the shape of isoseismals. Elliptical isoseismals are common, and Elby (1957) considers that their shape is caused by the mechanics of the shock and because the energy has difficulty in passing certain strongly reflecting boundaries.

The original isoseismal map for Meckering shows generally some eccentricities indicative of structural trends, and it is apparent that seismic shaking was propagated more easily towards the east than towards the west.

Observations of houses completely wrecked by shaking showed that the envelope of this type of damage extended 5 kilometres (3 miles) to the west of Meckering and about 20 kilometres (12 miles) to the east. Thus the general arcuate shape of the main fault can be matched by a zone of strong damage about 40 kilometres (25 miles) wide, extending in an arc from Meckering to Kununopin in the northeast and Corrigin in the southeast. This arcuate shape is nearly the same as the area enclosed by the pre-earthquake arc centred near Northam.

Seismic shaking was propagated from a source to the east of Meckering and on transmittal to the west met the strongly reflecting boundaries of the old arcuate faults. These geological barriers probably caused the partial confinement of the strong seismic shaking to the east, rather than allowing free propagation to the west towards Perth.

The Meckering earthquake was felt for 24 seconds in the metropolitan area, although some tall buildings apparently vibrated for as long as 3 minutes. Felt intensities varied from MMIV to MMVI and the Perth area contained an isolated isoseismal VI, separated from the corresponding isoseismal elliptical around the epicentral region by a distance of about 65 kilometres (40 miles). This local intensification of shaking occurred because the shock waves from the source, traversing granitic terrain, entered the unconsolidated sediments of the coastal plain at the Darling Fault. The local variations in the intensities were due to differing foundation conditions. Most of the structural damage was caused by seismic shaking, but there were several areas where landsliding and consolidation of saturated soils under the influence of shaking were responsible for the damage.

#### DISTANCES OF DESTRUCTIVE INTENSITY

The MMVI isoseismal, drawn 65 kilometres (40 miles) west and about 130 kilometres (80 miles) east of Meckering represents the damage limit of an earthquake. Isolated zones of MMVI intensity were recorded in the metropolitan area, the reason for such a local intensification being that the earth waves that are felt as shaking during an earthquake are different in different materials. In general, solid rock such as granite carries only short-period earthquake waves which cause a rippling motion. At the other extreme, deep unconsolidated saturated alluvial valley fill can support only long-period waves that result in a lurching surface motion. Obviously, structures located on unconsolidated sediments are likely to be subjected to much more violent shaking than those on hard rock, and sustain more earthquake damage. The correlation between local geology and intensity in Perth is given in a later section, but the metropolitan area has foundation conditions that cause local variations of intensity of seismic shaking.

Westerly geological discontinuities apparently shielded Perth from the Meckering shaking, but this shielding action was not apparent in the intensity patterns of the Meeberrie, Calingiri or Nourning Springs earthquakes. All showed slightly better propagation of shaking to the east than to the west, probably resulting from the earthquake mechanism.

Everingham and Gregson (1970) have given data of isoseismal radii for Western Australian earthquakes, which are shown in Table 1 and Figure 13. For destructive earthquakes (MMVII) the relationship shown in Table 1 is given for magnitude and radius, assuming both unconsolidated subsoil and crystalline rock.

TABLE 1. RELATIONSHIP BETWEEN MAGNITUDE AND RADIUS FOR WESTERN AUSTRALIAN EARTHQUAKES (EVERINGHAM & GREGSON, 1970)

Magnitude	Unconsolidated Subsoil	Crystalline Rock
	Radius MMVI-VII	Radius MMVI-VII
5.0	20 km — 12.5 miles	15 km — 9.3 miles
5.5	30 km — 18.5 miles	25 km — 15.5 miles
6.0	50 km — 31.0 miles	40 km — 25.0 miles
6.5	80 km — 50.0 miles	60 km — 37.0 miles
7.0	120 km — 74.5 miles	90 km — 55.5 miles
7.5	180 km — 112 miles	130 km — 80.5 miles
8.0	260 km — 161 miles	

#### EARTHQUAKE EFFECTS IN THE PERTH METROPOLITAN AREA

After the Meckering earthquake, observers on the coastal plain estimated intensities ranging from MMIV to MMVI. The local variation in intensities was due mainly to differing foundation conditions.

Felt intensities in the Coastal Limestone belt were notably lower than in surrounding districts. High intensities (MMVI) were reported from the city block, but the heights of the buildings occupied by the observers are not recorded. Between Bellevue and Midland and also at Guildford there were several reports of MMVI intensity and these correlate with reports of significant damage from this area recorded in the newspapers. This local intensification of shaking occurred because the shock waves from the source, traversing granitic terrain, entered the sediments of the coastal plain at the Darling Fault. The shaking in the Guildford area was intensified because of the reaction of Guildford clay foundations.

The most widespread type of damage was cracking of walls and of plaster ceilings, but the total extent of this damage will never be known, as many people were unsure of conditions before the earthquake. Two-storey houses were more badly affected than single-storey ones.

The Fire and Accident Underwriters Association of Western Australia has provided the statistics shown in Table 2 regarding earthquake claims submitted to member companies. The metropolitan area is defined as the area within a radius of 48 kilometres (30 miles) of the General Post Office in Perth.

TABLE 2. EARTHQUAKE DAMAGE—OCTOBER 1968—CLAIMS STATISTICS AS AT 28th FEBRUARY, 1969

Fire Policies			Houseowners and Household Policies		
	No. of Claims	Amount of Claims Incurred		No. of Claims	Amount of Claims Incurred
METRO-POLITAN		\$	METRO-POLITAN	6,450	697,748
Dwellings ....	33	7,850	.....	.....	.....
Other .....	357	202,250	.....	.....	.....
COUNTRY			COUNTRY	743	330,223
Dwellings ....	54	22,602	.....	.....	.....
Other .....	69	80,082	.....	.....	.....
Total number of claims .....				.....	7,706
Total amount of claims .....				.....	\$1,340,763

The best roster of structural damage to Perth buildings has been obtained by the earthquake committee of the Perth Chapter of the Australian Consulting Engineers Association (ACEA, 1970), and even this is restricted in scope. Buildings in the Perth City Council area were reported on by the City Building Surveyor and structural engineers. Of the 24 buildings that suffered structural damage, all were either old or were uncompleted shells under construction. In many cases the buildings had shown previous signs of deterioration because of subsidence or because of old age. In certain metropolitan areas, notably in the Canning district, some new buildings suffered structural damage because of the spreading of alluvial clay foundations.

Reclamation of land for the Kwinana Freeway and the Narrows Interchange involved the dumping of large quantities of sand to squeeze out the underlying mud. Several slips were developed during this operation and it was the reactivation of these old slip surfaces that caused subsidence and movement affecting the freeway. Movement of up to 30 centimetres (12 in) horizontally and vertically occurred (Marsh, 1969), causing depression and cracking of part of the freeway, damaging boat sheds and tilting jetties. There was subsidence behind the northern abutment of the Narrows Bridge as the approach road moved down about 1.9 centimetres (0.75 in) and 10 centimetres (4 in) laterally. The bridge abutment is contained in the fill and there could have been serious damage to the bridge had the movement been larger. Further reactivation of this particular slip surface in an earthquake would endanger the bridge.

The seismic shaking also tripped many of the State Electricity Commission's power transformers, and of 81 transformers, 24 registered relay operations (Le Souef, 1969). The trips were caused by the activation of relays operated either by oil movement inside the transformers, or by the stopping of mercury in mercury switches, or by a combination of both. At the Welshpool Substation no transformers tripped, but the support insulator of a capacitor stack was broken, this being the only structural damage to metropolitan installations.

The trippings were considered to be a possible guide to shaking intensities as related to foundation conditions. All six stations standing on solid limestone (calcarenite) of the Coastal Limestone survived the shaking without the tripping of any transformers. Two stations on the belt of unconsolidated Safety Bay or Recent sand to the west (seaward) side of the Coastal Limestone outcrop had 7 out of 17 transformers tripped.

In the Hamersley area, north of Perth, two stations were situated about 4 kilometres (2.5 miles) apart on similar leached sand of the Bassendean type. In one station the long axis of the transformers was east-west and both transformers were tripped. At the other station to the east, the long axis of the transformers lay north-south, and the two transformers were unaffected.

Transformers that were tripped in the Claremont, Daglish, City Beach and Innaloo areas are situated in small depressions on quartz sand leached from Coastal Limestone. The five transformers in the city area were not tripped, and these are all situated on relatively high locations with lime sand foundations. All transformers on the Bassendean leached sand and on the alluvial Guildford Formation were tripped, with the exception of the northerly orientated installation in the Hamersley area.

The three factors that prevented transformers from being tripped in the metropolitan area were:

- (1) solid foundations provided by the Coastal Limestone (calcarenite) formation;
- (2) the orientation of the transformers;
- (3) location on high points of unleached sand areas, where some intergranular cementation provided firmness.

#### EARTHQUAKES IN TIME

Individual earthquakes cannot be specifically predicted. However, it is possible to evaluate the seismic risk, and this may in turn lead to the enactment of regulations that require a certain degree of earthquake resistance in new structures, and the elimination of hazards in existing buildings.

New earthquakes cause constant revision of the estimates of seismicity and if the revisions are made on a consistent basis, the risk is invariably increased. A 1940 estimate of the seismicity of the State would have taken notice of the fact that no seismic event greater than magnitude 6.25 had been recorded on land and that the nearest epicentre of any earthquake of magnitude greater than 6 was over 600 kilometres (380 miles) away. The Meeberrie earthquake, with an epicentre 587 kilometres (365 miles) north of Perth, was assigned a magnitude of 6.75 at the time of occurrence, later upgraded to 7.5. The installation of modern three-component seismographs at Mundaring in 1959 enabled the delineation of several zones of seismic activity, especially the South West Seismic Zone, the presence of which had already been inferred from the older, less accurate records of Perth Observatory. The results of 6 years of instrumental recording were summed up by Everingham (1968) as follows: "... buildings along the Yandanooka/Cape Riche Lineament should certainly be built to withstand small shocks (local magnitude 4 to 5) as tremors of this magnitude would occur very close to them. It also seems reasonable to expect even larger shocks here, perhaps one in each 50-year or 100-year period; such shocks might even affect some buildings in Perth". On statistical grounds, it has been further concluded that "the seismicity and intensity data suggest that Perth and the majority of the more heavily populated parts of Western Australia are likely to suffer relatively dangerous intensities of MMVII or more on an average of every few hundreds of years".

#### SUGGESTED EARTHQUAKE RISK ZONING

In attempting to divide the State into zones of equal risk, only a small amount of incomplete information is available. Ten years of accurate seismic records and about 80 years of historical records are very meagre evidence on which to estimate the earthquake risk. The remarkable fault scarps of Meckering and Calingiri have prompted geological examination for traces of similar faulting in adjacent areas, and numerous arcuate and circular stream patterns in the southwest of the State are considered to be indicative of tectonic movement in the past. It is apparent that the geological and seismic data are closely inter-related and confirmatory.

Figure 9 is a seismotectonic map which gives three main categories of earthquake risk zone for Western Australia, and an "aseismic" zone in the eastern interior of the State. The zonation is based on information available in November, 1970 and will probably be modified by subsequent events and further research.

### EARTHQUAKE CODES

Structural and civil engineers have the task of translating risk factors into suitable criteria for designing a building. Usually the design procedures follow an accepted building code. The writing of a workable code is a demanding technical task, and enforcement and administration of the code must be of the highest standard.

### CONSULTING ENGINEERS' RECOMMENDATIONS

The Perth Chapter of the Association of Consulting Engineers of Australia (ACEA) set up a committee to evaluate the effects of the Meckering earthquake and to make recommendations concerning earthquake risk zoning and provision against earthquake effects. The results of the study, released in August 1970, dealt only with the southwest corner of the State. The Earthquake Provisions of the New Zealand Buildings By-laws, NZSS 1900 were recommended as a suitable code for earthquake-resistant design, to be applied as follows:

Western Australia Earthquake Risk Zone "B"—NZSS 1900, Zone B loading;

Western Australia Earthquake Risk Zone "C"—one half of NZSS 1900, Zone C lateral load factor.

Excellent summaries of recommended practice for structural design and building services design were included in the report (ACEA, 1970). The estimated cost of providing resistance in building frames to

an earthquake of severity equal to half of New Zealand Zone C would be in the order of 1 per cent of the total cost of the building.

### RECOMMENDED INTERIM CODE

The principles of earthquake-resistant design have been clearly documented in a publication of the UNESCO (1964).

Until better records are available, and the foundation soils of Perth are zoned, it would be advisable to adopt an existing code for Western Australia. The New Zealand Code has proved effective and is relatively simple and it is considered to offer a good interim code of practice. As there is no reason to believe that the strongest shaking so far experienced in Perth could not be exceeded, it is recommended that the full New Zealand coefficient for Zone C should be applied. For Zone B, the corresponding New Zealand coefficient should be applied. Similarly the full Zone A coefficient should be applied to the Yerecoin-Calingiri-Meckering tectonic belt.

### BUILDING PRIVATE HOUSES IN EARTHQUAKE RISK ZONES

The New Zealand Model Building By-law (NZSS 1900, Chapter 8) allows unreinforced masonry for single or double unit dwellings, even in Zone A. The usual building material in New Zealand is wood and many engineers consider it inadvisable to build in unreinforced brickwork, especially in Zone A. In Western Australia, where most houses are constructed of unreinforced brickwork, it is not desirable to ban the use of this type of construction. However, anyone building in Zones A, B or C should be aware of the performance of the various types of building materials in the Meckering earthquake, as summarized in Table 3.

TABLE 3. DAMAGE TO MECKERING BUILDINGS, OCTOBER 14, 1968

Wall material	No. of buildings surveyed	Per cent of total	Demolished	Per cent	Minor damage	Per cent	Negligible damage	Per cent
Timber	27	30.7	2	7.4	16	59.2	9	33.4
Steel frame	2	2.3	...	...	...	...	2	100
In situ concrete	1	1.1	...	...	1	100	...	...
Brick veneer	1	1.1	...	...	1	100	...	...
Brick or brick and stone	32	36.4	31	97	1	3	...	...
Concrete block	4	4.5	4	100	...	...	...	...
Mud and concrete	16	18.2	16	100	...	...	...	...
Block or bricks	...	...	...	...	...	...	...	...
Timber and brick stone or concrete blocks	5	5.7	4	80	1	20	...	...
Totals	88	...	57	...	20	...	11	...
Per cent of totals	...	...	...	64.8	...	22.7	...	12.5

Smith (1969) stated that masonry, mud and concrete blocks were unsuitable building media for structures in the Meckering area, particularly as little attention had been given to adequate bonding or reinforcement of walls. These types of unreinforced masonry are also unsuitable for buildings in any part of the South West Seismic Zone. Timber or steel frames clad in timber, asbestos or polystyrene, or polystyrene panels, are recommended types of lightweight construction for seismic areas. Brick veneer with a wooden frame would be acceptable if tying to the frame, adequate detailing and some reinforcing, were incorporated. Concrete block construction, reinforced vertically and horizontally and founded on a concrete slab, would be adequate, as would reinforced double brick on a concrete slab. The recommendations of the ACEA earthquake committee (1970) on structural design should be carefully studied by all people concerned with building design and construction.

The Meckering experience showed that brick or unit masonry chimneys were a hazard. For preference, chimneys should be made of metal or reinforced concrete rather than of brick or blocks. Lightweight roofs are recommended.

Good foundations are as important as earthquake-resistant construction, and in order of preference the recommended foundation types of the

Earthquake Risk Zones are solid rock, weathered granite or laterite, and firm sandy soil.

Heavy clay or alluvial or peaty soils should be avoided, but if it is essential to build on them additional care should be taken with the frame and foundations. It is most desirable to have uniform foundation material and to avoid varying soils. A concrete slab footing or continuous wall footings are recommended.

In certain suburbs in the metropolitan area, building in other than double brick is not allowed. These local ordinances should be re-examined carefully in the light of earthquake risk.

### HAZARD OF EXISTING BUILDINGS IN EARTHQUAKE RISK ZONES

Many of the buildings of the towns in the Earthquake Risk Zones A and B present serious hazards. It would not be justifiable economically to strengthen most of these buildings, even if it was practically feasible. A special hazard comes from the many buildings with masonry walls, particularly those with non-reinforced brick-bearing walls held together by lime mortar. Buildings of this nature of more than one storey are particularly vulnerable to collapse in a major earthquake. Table 4 gives a comparison of the damage susceptibility of various forms of construction.

TABLE 4. HAZARD COMPARISON OF NON-RESISTIVE BUILDINGS

Simplified description of structural type	Relative damageability (in order of increasing susceptibility to damage)
Small wood-frame structures, i.e. dwelling not over 280 square metres (3,000 ft <sup>2</sup> ) and not over three storeys	1
Single or multi-storey steel-frame buildings with concrete exterior walls, concrete floors and concrete roof. Moderate wall openings	1-5
Single or multi-storey reinforced concrete buildings with concrete exterior walls, concrete floor and concrete roof. Moderate wall openings	2
Large area wood-frame buildings and other wood-frame buildings	3 to 4
Single or multi-storey steel-frame buildings with unreinforced masonry exterior wall panels, concrete floor and concrete roof	4
Single or multi-storey reinforced concrete-frame buildings with unreinforced masonry exterior wall panels, concrete floors and concrete roof	5
Reinforced concrete-bearing walls with supported floors and roof of any material (usually wood)	5
Buildings with unreinforced brick masonry having sand lime mortar and with supported floors and roof of any materials (often wood)	7 up
Bearing walls of unreinforced adobe (mud brick), unreinforced to hollow concrete blocks or unreinforced hollow clay tile	Collapse hazard in moderate shocks

Note: This table is intended for buildings not containing earthquake bracing and in general is applicable to most older constructions. Unfavourable foundation conditions and dangerous roof tanks can increase the earthquake hazard greatly  
Source: Abridged from Pacific Fire Rating Bureau Tariff Rules, California, U.S.A.

It has already been recommended that a specific seismic building code should be introduced for Earthquake Risk Zones A and B, but the bracing of existing buildings is not recommended except possibly in certain serious cases. It is not economic to rebuild towns, as the impracticability of bracing the existing structures would normally mean their removal. Most seismic building codes contain a clause defining what constitutes a public nuisance as far as a building is concerned, and contain the legal means to remove the hazard. In practice however, this type of legal tool is rarely applied and the common method for upgrading the safety of buildings is to require improvements when building permits are issued for additions or repairs.

An earthquake shock may damage a building far more gravely than is superficially apparent, leaving it vulnerable to subsequent shocks, especially if internal damage has occurred. In other words, earthquake damage is cumulative and because a structure has apparently survived earthquake shaking of intensity VII, it does not mean that damage will not occur until a greater intensity is reached. It is quite possible that a low intensity of shaking could produce severe damage.

There is no doubt that Perth—and Northam and York—will be subjected to further seismic shaking, which even when slight will increase the danger of already damaged buildings collapsing. All buildings, chimneys and ornamentations should therefore be re-examined and repaired if necessary. Old churches in particular need careful examination for structural defects.

A fortnight after the Meckering earthquake, during a period of sharply felt aftershock activity, a correspondent in the Perth morning paper raised the question of the safety of existing brick and tile houses in the South West Seismic Zone. Five specific questions were asked, although no reply was made to the letter, the topics are pertinent enough and of such public interest as to warrant discussion. The five questions were:

- (1) Is there any way of rendering existing brick structures safer in case of future tremors?
- (2) If unable to leave the building in time (say during the night), where is the safest place to be in a brick building?
- (3) Do masonry walls fall out, in, or simply crumble, and are internal walls any more stable than external ones?
- (4) Has the existence of the seismic zone centred on Meckering been known for long, or was it considered to be of minor importance or relatively inactive?
- (5) Are any other zones known or suspected in Western Australia?

An existing brick and tile building can be made safer in several ways, but the complete process of reinforcing may be more costly than building a new house of non-masonry construction. The following considerations may be of interest:

- (1) A tile roof is often a destructive agent because of its inertia when shaken. The simplest method of preventing damage by the movement of the heavy roof is to replace the tiles with a light material such as aluminium (sheets or tiles) or corrugated iron.

Brick chimneys break, particularly at the roof-line and damage caused by bricks falling through a roof above unlined sleep-outs is a hazard that can be met by strengthening the roof or the ceiling; or the danger can be eliminated by replacing with a metal chimney. With the advent of electric ranges and the use of central heating, many chimneys are no longer needed.

To strengthen brickwork, it is usual to use reinforced concrete bands and ties at foundation, plinth, lintel and roof levels. Internal grouting of double brick walls has been used in repairing damaged buildings, combined with external reinforcing ties.

- (2) The safest place in a brick building is under a table, bed, or a doorway.
- (3) Masonry walls may fall in any direction. Internal partition walls often remain supporting the roof, even though the outside brick walls have collapsed. The safest part of the house is probably under a wooden door frame in an inside or partition wall.
- (4) The existence of the South West Seismic Zone has been known for some years and public warnings of danger have been made by the Geophysical Observatory at Mundaring and by the Geological Survey of Western Australia.
- (5) Other seismic zones exist in Western Australia, as is apparent in this report.

#### EARTHQUAKE EDUCATION

To be useful, information on earthquake hazards and how to cope with them must reach not only practising scientists, design engineers, architects, education authorities, building officials and local government officers, but the informed public as well. Panic is contagious, and people should be told by Civil Defence what they have to do in an earthquake emergency.

#### RECOMMENDATIONS

It is not possible to predict when, where, or how big the next earthquake will be. Regions are known in which earthquakes are likely to occur, but there is inadequate statistical evidence of their frequency and magnitude. Knowledge can only be increased by instrumentation and geological research. The following recommendations are made in the light of present knowledge:

## ZONING

Three graded zones of relative earthquake risk have been established, along with an unzoned area. This zoning has indicated the areas which are more liable to damaging earthquakes than others.

The risk of earthquake occurrence focusses attention on the importance of designing structures to withstand the stresses produced by the motion of the ground. No one has ever been shaken to death by an earthquake, and it is the collapse of man-made structures that causes the casualties. Structures must be designed to resist earthquakes, to prevent personal injury and loss of human life, to minimize damage to property and to ensure continuity of vital services.

Until our own earthquake codes are prepared, the use of the New Zealand code is recommended.

## BUILDING HAZARDS

Owners of existing buildings in the earthquake risk zones should be encouraged to remove hazards such as brick chimneys, parapets and ornamentations.

People intending to build in Zone "B" should be made aware of the necessity for good foundations and for using earthquake-resistant construction.

The compulsory use of brick in certain metropolitan suburbs should be reviewed carefully by the local authorities in the light of seismic risk.

Strong motion instruments (accelerographs) should be established in buildings to provide the basic data for a local code. Scratch-plate accelerometers, which are cheap and reliable instruments for measuring one horizontal acceleration, should be installed throughout the active seismic zones (Appendix 2).

Existing hazards in the risk zones should be the subject of legislation to enable the immediate removal of unsafe structures and the gradual phasing out of potential hazards such as parapets and ornamentations.

All mining towns with underground workings should be designed to resist seismic shaking resulting from local rock-burst activity.

## PREDICTION OF EARTHQUAKES

Geodimeter and precise levelling traverses should be made by the Lands and Surveys Department across suspected earthquake structures and re-observed periodically.

Further work should be done on water level recorders in the Gnangara wells, which gave a 1½-hour "warning" rise of water level before the Meckering earthquake. Instrumentation should be studied to bring signals to Perth. New wells should be established south of Perth, possibly in the Jandakot area, to determine if similar conditions apply, thus providing a more comprehensive warning system.

## EDUCATION

The notes on "What to do during an earthquake" could be given wide circulation, especially in schools.

The public should be periodically reminded of the seismicity of the State by means of showings of films of the Meckering earthquake and the publication of studies of the Meckering and Calingiri earthquakes.

## REFERENCES

- A.C.E.A., 1970, Earthquake resistant design, Western Australia: West. Australia Chapter, Assoc. Consult. Eng. Aust.
- Baraganzi, M., and Dorman, J., 1968, World seismicity maps compiled from E.S.S.A., Coast and Geodetic Survey, epicenter data, 1961-1967 Earthquake notes, v. 39, no. 3-4, p. 15-16.

- Clark, R. H., Dibble, R. R., Fyfe, H. E., Lensen, G. J., and Suggate, R. P., 1965, Tectonic and earthquake risk zoning: Royal Soc. New Zealand Trans. v. 1, no. 10, p. 113-126.
- Cluff, L. S., 1968, Urban development within the San Andreas Fault System: Proc. Conf. on Geol. Problems San Andreas Fault System. Stanford Univ. Pub. v. XI.
- Doyle, H. A., 1971, Seismicity and structure in Australia: Royal Soc. New Zealand Symp. on Recent Crustal Movements.
- Eiby, G. A., 1957, Earthquakes: Muller.
- 1966, The Modified Mercalli scale of earthquake intensity and its use in New Zealand: New Zealand Jour. Geol. Geophys. 9, p. 122-9.
- 1968, Earthquakes and fire: New Zealand Seismol. Observ. Bull. 5151.
- Everingham, I. B., 1968, Seismicity of Western Australia: Australia Bur. Mineral Resources Rept. 132.
- Everingham, I. B., and Gregson, P. J., 1969, Meckering Earthquake intensities and notes on earthquake risk for Western Australia: Australia Bur. Mineral Resources Rec. 1970/97 (unpublished).
- Gordon, F. R., and Wellman, H. W., 1971, Earthquake strain release at Meckering, Western Australia: Royal Soc. New Zealand Symp. on Recent Crustal Movements.
- Le Souef, F. A. W., 1969, The effects of the Meckering Earthquake on the State Electricity Commission's Plant: Aust. Inst. Eng. West. Australia Div., Earthquake Symp.
- Marsh, G. J., 1969, The effect of the Meckering Earthquake on roads and bridges: Aust. Inst. Eng. West. Australia Div., Earthquake Symp.
- New Zealand Standards Institute, 1965a, N.Z.S.S. 1900, Basic design loads: New Zealand Standard Model Building By-law.
- 1965b, Commentary on Chapter 8 of N.Z.S.S. 1900: New Zealand Standards Inst. Misc. Pub. MP 12.
- Playford, P. E., 1967, The Darling Fault: A.N.Z.A.A.S. Abstract Sect. C, Adelaide.
- Richter, C. F., 1958, Elementary Seismology: Freeman.
- Seed, H. B., 1968, Landslides during earthquakes due to soil liquefaction: Am. Soc. Civil Engineers Proc. v. 94, paper 6110. Jour. Soil Mechanics & Found. Div. no. SM5, p. 1055-1122.
- Smith, A. W., 1969, Buildings in Meckering: Aust. Inst. Eng. West. Australia Div., Earthquake Symp.
- UNESCO, 1964, Report of the UNESCO working group on the principles of earthquake resistant design: UNESCO/NS/SEISM/6, Paris.
- Wallace, R. E., 1968, Geologic factors in earthquake damage: Cento Conference on earthquake hazard minimization, Ankara.

## APPENDIX 1

### WHAT TO DO DURING AN EARTHQUAKE

Earthquakes are something we have to tolerate; there is at present not much hope of prediction and none of running away. The maximum violence of a destructive shock is generally reached within 10 seconds of the first tremor and it is necessary to act as soon as possible. No one has yet been shaken to death; human lives are lost from the collapse of man-made structures. More people have been killed by rubble falling in the streets than have been killed inside the buildings themselves.

### IF YOU ARE IN A HOUSE AT THE ONSET OF AN EARTHQUAKE

1. Move away from any fireplaces, windows and tall bookcases.
2. Get under a table or a desk or into a doorway or under any strong covering that will protect you from a falling ceiling or wall.

3. Do not run out of the front door where you may be struck by falling bricks or cornices.

*IF YOU ARE IN THE CITY STREET*

1. Move into an open doorway or immediately out into an open space, but watch out for cars!

2. Do not stay on the footpath as more rubble falls on to the street than inside the buildings.

*IF YOU ARE IN A TALL BUILDING*

Stay in it and get under cover; you could not get out in time anyway and you may get crushed in a stairway or lift if everyone panics.

*IF YOU ARE IN A SCHOOLROOM*

Do not do anything until told by your teacher. If there is no teacher in the room, get under your desk or table until the shaking stops, then get out of the building quietly and in an alert fashion. Be especially careful when leaving the building and watch for falling bricks.

*GENERAL*

Never reoccupy a damaged building without the approval of local authorities. Earthquake damage accumulates and just because a building has withstood, or partly withstood, a large shock, it does not mean it will take any more (even minor) shocks.

Do not light a fire in a fireplace that may have been affected by an earthquake. A concealed crack may start a house fire.

**APPENDIX 2**

**RECOMMENDED STRONG MOTION INSTRUMENTATION**

(a) There is a special engineering need for measurements of the strong ground shaking of earthquakes, and the consequent oscillation of buildings. Such recordings are fundamental for earthquake engineering research aimed at developing safe and economical earthquake-resistant buildings, and the State has a responsibility to provide such recordings.

(b) The instrument recommended is the MO2-type accelerograph developed by the Physics and Engineering Laboratory of the Department of Scientific and Industrial Research of New Zealand. These high-performance, low-cost instruments are self triggering at the onset of shaking, and maintenance amounts to little more than yearly battery changes.

(c) The Bureau of Mineral Resources Geophysical Observatory at Mundaring currently has three MO2 instruments. These are available to record ground movement, but not building oscillations. A strong motion centre is being set up in Canberra where all records from MO2 can be processed.

It is recommended that three Government buildings in the metropolitan area should be instrumented to cover a range of foundation and structural types at the following locations:

- (1) Government Superannuation Building, Saint George's Terrace, foundation type raft, on unlithified Coastal Limestone sand; three instruments to be installed on the basement, middle floor and top floor respectively;
- (2) Mineral House, 66 Adelaide Terrace, concrete raft on Guildford clay; one instrument to be installed on the 4th floor;
- (3) Government Offices Building, 2 Havelock Street, West Perth, on unlithified Coastal Limestone in a dune-top position; one instrument to be installed on the top (13th) floor;
- (4) two instruments should be installed in Earthquake Risk Zone B in government buildings in Pingelly and Wongan Hills;
- (5) one instrument should be installed in the Port Authority building at Port Hedland.

(d) Scratch-plate accelerometers are a cheap instrument that records the maximum horizontal acceleration of one earthquake shock. It is recommended that at least 20 of these instruments should be obtained and installed in selected police stations in Earthquake Risk Zones A and B.

**APPENDIX 3**

**MODIFIED MERCALLI SCALE, N.Z. VERSION, 1965, (EIBY, 1966)**

*MM I*

Not felt by humans, except in especially favourable circumstances, but birds and animals may be disturbed. Reported mainly from the upper floors of buildings more than 10 storeys high. Dizziness or nausea may be experienced.

Branches of trees, chandeliers, doors, and other suspended systems of long natural period may be seen to move slowly. Water in ponds, lakes, reservoirs, etc., may be set into seiche oscillation.

*MM II*

Felt by a few persons at rest indoors, especially by those on upper floors or otherwise favourably placed. The long-period effects listed under MMI may be more noticeable.

*MM III*

Felt indoors, but not identified as an earthquake by everyone. Vibration may be likened to the passing of light traffic. It may be possible to estimate the duration but not the direction. Hanging objects may swing slightly. Standing motorcars may rock slightly.

*MM IV*

Generally noticed indoors, but not outside. Very light sleepers may be wakened. Vibration may be likened to the passing of heavy traffic, or to the jolt of a heavy object falling or striking the building. Walls and frame of buildings are heard to creak. Doors and windows rattle. Glassware and crockery rattles.

Liquids in open vessels may be slightly disturbed. Standing motorcars may rock, and the shock can be felt by their occupants.

*MM V*

Generally felt outside, and by almost everyone indoors.

Most sleepers awakened.

A few people frightened.

Direction of motion can be estimated.

Small unstable objects are displaced or upset.

Some glassware and crockery may be broken.

Some windows cracked.

A few earthenware toilet fixtures cracked.

Hanging pictures move.

Doors and shutters may swing.

Pendulum clocks stop, start, or change rate.

*MMVI*

Felt by all.

People and animals alarmed.

Many run outside.

Difficulty experienced in walking steadily.

Slight damage to Masonry D.

Some plaster cracks or falls.

Isolated cases of chimney damage.

Windows, glassware, and crockery broken.

Objects fall from shelves, and pictures from walls.

Heavy furniture moved. Unstable furniture overturned.

Small church and school bells ring.

Trees and bushes shake, or are heard to rustle.

Loose material may be dislodged from existing slips, talus slopes, or shingle slides.

*MMVII*

General alarm.

Difficulty experienced in standing.

Noticed by drivers of motorcars.

Trees and bushes strongly shaken.



Large bells ring.  
 Masonry D cracked and damaged.  
 A few instances of damage to Masonry C.  
 Loose brickwork and tiles dislodged.  
 Unbraced parapets and architectural ornaments may fall.  
 Stone walls cracked.  
 Weak chimneys broken, usually at the roof-line.  
 Domestic water tanks burst.  
 Concrete irrigation ditches damaged.  
 Waves seen on ponds and lakes.  
 Water made turbid by stirred-up mud.  
 Small slips, and caving-in of sand and gravel banks.

**MM VIII**

Alarm may approach panic.  
 Steering of motorcars affected.  
 Masonry C damaged, with partial collapse.  
 Masonry B damaged in some cases.  
 Masonry A undamaged.  
 Chimneys, factory stacks, monuments, towers, and elevated tanks twisted or brought down.  
 Panel walls thrown out of frame structures.  
 Some brick veneers damaged.  
 Decayed wooden piles broken.  
 Frame houses not secured to the foundation may move.  
 Cracks appear on steep slopes and in wet ground.  
 Landslips in roadside cuttings and unsupported excavations.  
 Some tree branches may be broken off.  
 Changes in the flow or temperature of springs and wells may occur.  
 Small earthquake fountains.

**MM IX**

General panic.  
 Masonry D destroyed.  
 Masonry C heavily damaged, sometimes collapsing completely.  
 Masonry B seriously damaged.  
 Frame structures racked and distorted.  
 Damage to foundations general.  
 Frame houses not secured to the foundations shifted off.  
 Brick veneers fall and expose frames.  
 Cracking of the ground conspicuous.  
 Minor damage to paths and roadways.  
 Sand and mud ejected in alluviated areas, with the formation of earthquake fountains and sand craters.  
 Underground pipes broken.  
 Serious damage to reservoirs.

**MM X**

Most masonry structures destroyed, together with their foundations.  
 Some well built wooden buildings and bridges seriously damaged.

Dams, dykes, and embankments seriously damaged.  
 Railway lines slightly bent.  
 Cement and asphalt roads and pavements badly cracked or thrown into waves.  
 Large landslides on river banks and steep coasts.  
 Sand and mud on beaches and flat land moved horizontally.  
 Large and spectacular sand and mud fountains.  
 Water from rivers, lakes, and canals thrown up on the banks.

**MM XI**

Wooden frame structures destroyed.  
 Great damage to railway lines.  
 Great damage to underground pipes.

**MM XII**

Damage virtually total. Practically all works of construction destroyed or greatly damaged.  
 Large rock masses displaced.  
 Lines of sight and level distorted.  
 Visible wave-motion of the ground surface reported.  
 Objects thrown upwards into the air.

**CATEGORIES OF NON-WOODEN CONSTRUCTION**

**Masonry A**

Structures designed to resist lateral forces of about 0.1 g, such as those satisfying the New Zealand Model Building By-law, 1955. Typical buildings of this kind are well reinforced by means of steel or ferro-concrete bands, or are wholly of ferro-concrete construction. All mortar is of good quality and the design and workmanship is good. Few buildings erected prior to 1935 can be regarded as in category A.

**Masonry B**

Reinforced buildings of good workmanship and with sound mortar, but not designed in detail to resist lateral forces.

**Masonry C**

Buildings of ordinary workmanship, with mortar of average quality. No extreme weakness, such as inadequate bonding of the corners, but neither designed nor reinforced to resist lateral forces.

**Masonry D**

Buildings with low standards of workmanship, poor mortar, or constructed of weak materials like mud brick and rammed earth. Weak horizontally.

**PETROLEUM EXPLORATION IN WESTERN AUSTRALIA IN 1971**

by P. E. Playford and G. H. Low

**ABSTRACT**

There was a considerable increase in the tempo of oil exploration in Western Australia during 1971, associated with several important gas discoveries. The largest finds were made by the B.O.C. group on the Northwest Shelf, in the Scott Reef No. 1, North Rankin No. 1, Rankin No. 1 and Goodwyn No. 1 wells. The gas in each of these wells also contains significant amounts of condensate, and some oil was recovered from Rankin No. 1. Another gas discovery was made by West Australian Petroleum Pty. Ltd. in Walyering No. 1 well in the Perth Basin.

Twenty-nine holes were completed during the year, for a total of 70,620 metres (231,694 ft) of drilling. This was more than double the amount for the previous year. Geophysical and field

geological exploration also increased considerably. Several new petroleum concessions were issued during the year, and a number of new areas have been made available for application.

**INTRODUCTION**

Exploration in Western Australia expanded considerably during 1971 as compared with the previous year. Exploratory drilling increased as shown in the following tabulation:

	Wells Completed		Wells Drilling 31 December	
	1970	1971	1970	1971
New field wildcat wells ....	10	22	4	1
Extension test wells ....	0	1	0	0
Stratigraphic wells ....	1	6	0	1
Total Drilling :	1970—31,672 metres (103,917 ft) 1971—70,620 metres (231,694 ft)			

Five of the 1971 wells made significant hydrocarbon discoveries (gas or gas and condensate), whereas there were no discoveries in the previous year.

Production figures quoted in the text are given in thousands of cubic metres per day ( $\times 10^3 \text{m}^3/\text{d}$ ) and millions of cubic feet per day (MMCF/d). Oil and condensate production is quoted in barrels only, as the barrel is internationally accepted as the standard volumetric unit in the petroleum industry. Oil production is quoted in metric tons, and the conversion factor from barrels varies according to the gravity of the oil or condensate. For Barrow Island crude this factor is approximately 7.5 bbl/metric ton.

Geophysical and geological survey activity also increased compared with 1970. The totals for 1971 were as follows:

Type of survey	Line Kilometres	Party months or Geologist months
Land Seismic	2,744	.....
Marine Seismic	19,933	.....
Aeromagnetic	16,133	.....
Ship-board magnetic	8,101	.....
Gravity	.....	13.9
Geological	.....	13.5

### PETROLEUM TENEMENTS

A number of new petroleum tenements were issued during the year. West Australian Petroleum Pty. Ltd. (Wapet) was granted Production Licenses 1 and 2 (covering the Dongara, Yardarino, and Mondarra fields) and 3 (covering the Walyearing field). The company was also granted EP 67 in the Canning Basin and EP 60-66 covering a number of small offshore islands in the northern Carnarvon Basin.

Authorities were granted to several companies for access to permits not held in their name and to conduct scientific investigations in areas not currently held as tenements.

At the end of the year a number of applications were under consideration for areas gazetted as being available for issuing as exploration permits under the onshore and offshore petroleum acts. Applications have also been received for the relinquishment of two offshore permit areas, WA-22-P and WA-27-P.

Petroleum tenements held in the State are shown on Plate 7, and the following tabulation lists details of the various holdings.

### PETROLEUM TENEMENTS UNDER THE PETROLEUM (SUBMERGED LANDS) ACT 1967

#### Exploration Permits

Number	No. of grati- cular sections	Expiry date of current term	Registered holder or applicant
WA-1-P	364	14/11/74	Woodside Oil N.L., Shell Development (Australia) Pty. Ltd., B.O.C. of Australia Ltd.
WA-2-P	381	14/11/74	West Australian Petroleum Pty. Ltd.
WA-7-P	135	10/7/75	Continental Oil Co. of Aust. Ltd., Australian Sun Oil Co. Ltd.
WA-8-P	18	17/6/75	Coastal Petroleum N.L.
WA-9-P	56	17/6/75	" " "
WA-10-P	36	15/6/75	" " "
WA-12-P	5	11/9/75	Associated Australian Oilfields N.L.
WA-13-P	337	29/8/74	West Australian Petroleum Pty. Ltd.
WA-14-P	396	29/8/74	" " "
WA-15-P	352	20/3/75	Australian Aquitaine Petroleum Pty. Ltd., Arco Ltd.
WA-16-P	354	16/4/75	" " " " " "
WA-17-P	378	22/4/75	" " " " " "
WA-18-P	322	16/4/75	" " " " " "
WA-19-P	142	20/3/75	Alliance Oil Development Australia N.L.
WA-20-P	34	10/10/74	West Australian Petroleum Pty. Ltd.
WA-21-P	241	14/11/74	" " " " " "
WA-22-P	81	3/10/74	" " " " " "
WA-23-P	398	3/10/74	" " " " " "
WA-24-P	208	17/10/74	" " " " " "
WA-25-P	256	16/10/74	" " " " " "
WA-26-P	400	22/12/74	Canadian Superior Oil (Aust.) Pty. Ltd., Australian Superior Oil Co. Ltd., Phillips Australian Oil Co., Sunray Australian Oil Co. Inc.
WA-27 P	294	18/5/75	" " " " " "

Number	No. of grati- cular sections	Expiry date of current term	Registered holder or applicant
WA-28-P	375	24/3/75	Woodside Oil N.L., Shell Development (Australia) Pty. Ltd., B.O.C. of Australia Ltd.
WA-29-P	400	18/5/75	" " " " " "
WA-30-P	400	2/7/75	" " " " " "
WA-31-P	400	18/5/75	" " " " " "
WA-32-P	395	2/7/75	" " " " " "
WA-33-P	389	18/5/75	" " " " " "
WA-34-P	397	2/7/75	" " " " " "
WA-35-P	400	2/7/75	" " " " " "
WA-36-P	57	18/5/75	" " " " " "
WA-37-P	118	2/6/75	" " " " " "
WA-39-P	104	12/3/75	B.P. Petroleum Development Australia Pty. Ltd., Abrolihos Oil N.L.
WA-40-P	102	12/3/75	" " " " " "
WA-41-P	33	15/6/75	Coastal Petroleum N.L.

### PETROLEUM TENEMENTS UNDER THE PETROLEUM ACT 1936

#### Petroleum Leases

Number	Area (square miles)	Expiry date of current term	Holder
IH	100	2/2/88	West Australian Petroleum Pty. Ltd.
2H	100	2/2/88	" " " " " "

### PETROLEUM TENEMENTS UNDER THE PETROLEUM ACT 1967

#### Exploration Permits

Number	No. of grati- cular sections	Expiry date of current term	Registered holder or applicant
EP 3	200	27/8/75	West Australian Petroleum Pty. Ltd.
EP 5	182	26/7/75	" " " " " "
EP 6	199	27/8/75	" " " " " "
EP 7	200	27/8/75	" " " " " "
EP 8	200	.....	" " " " " "
EP 9	200	27/8/75	" " " " " "
EP 12	182	3/9/75	" " " " " "
EP 13	200	27/8/75	" " " " " "
EP 14	200	27/8/75	" " " " " "
EP 15	200	27/8/75	" " " " " "
EP 16	200	27/8/75	" " " " " "
EP 17	200	27/8/75	" " " " " "
EP 18	200	27/8/75	" " " " " "
EP 19	200	27/8/75	" " " " " "
EP 20	200	.....	Australian Aquitaine Petroleum Pty. Ltd.
EP 21	90	26/7/75	West Australian Petroleum Pty. Ltd.
EP 23	188	6/8/75	" " " " " "
EP 24	187	6/8/75	" " " " " "
EP 25	96	6/8/75	" " " " " "
EP 26	1	27/8/75	BP Petroleum Development, Abrolihos Oil N.L.
EP 27	2	19/8/75	" " " " " "
EP 28	4	19/8/75	" " " " " "
EP 29	7	19/8/75	" " " " " "
EP 31	200	6/10/75	Beach-General Exploration Pty. Ltd., Australian Aquitaine Petroleum Pty. Ltd.
EP 32	200	15/4/76	" " " " " "
EP 33	123	15/4/76	" " " " " "
EP 34	1	15/4/76	Woodside Oil N.L., Shell Development (Australia) Pty. Ltd., B.O.C. of Australia Ltd.
EP 35	1	15/4/76	" " " " " "
EP 36	1	15/4/76	" " " " " "
EP 37	149	22/9/75	West Australian Petroleum Pty. Ltd.
EP 38	130	22/9/75	" " " " " "
EP 39	180	22/9/75	" " " " " "
EP 40	87	26/7/76	" " " " " "
EP 41	180	.....	" " " " " "
EP 42	200	1/9/75	" " " " " "
EP 43	163	1/9/75	" " " " " "
EP 44	113	1/9/75	" " " " " "
EP 45	197	19/11/75	Continental Oil Co. of Aust. Ltd., Australian Sun Oil Co. Ltd.
EP 46	199	1/9/75	" " " " " "
EP 47	199	19/11/75	" " " " " "
EP 48	199	19/11/75	" " " " " "
EP 50	110	1/9/75	West Australian Petroleum Pty. Ltd.
EP 51	57	8/9/75	Lennard Oil N.L.
EP 52	34	8/9/75	" " " " " "
EP 53	49	15/9/75	West Australian Petroleum Pty. Ltd.
EP 54	123	22/9/75	Alliance Oil Development Aust. N.L.
EP 55	178	22/9/75	West Australian Petroleum Pty. Ltd.
EP 58	200	20/7/76	Associated Australian Oilfields N.L., Australian Aquitaine Petroleum Pty. Ltd., Abrolihos Oil N.L., Ashburton Oil N.L., Flinders Petroleum N.L., Longreach Oil Ltd., Pursuit Oil N.L.
EP 59	186	18/7/76	" " " " " "
EP 60	2	" " " " " "	West Australian Petroleum Pty. Ltd.
EP 61	4	19/9/76	" " " " " "
EP 62	8	19/9/76	" " " " " "
EP 63	4	19/9/76	" " " " " "
EP 64	1	" " " " " "	" " " " " "
EP 65	2	19/9/76	" " " " " "
EP 66	1	19/9/76	" " " " " "
EP 67	29	25/10/76	" " " " " "

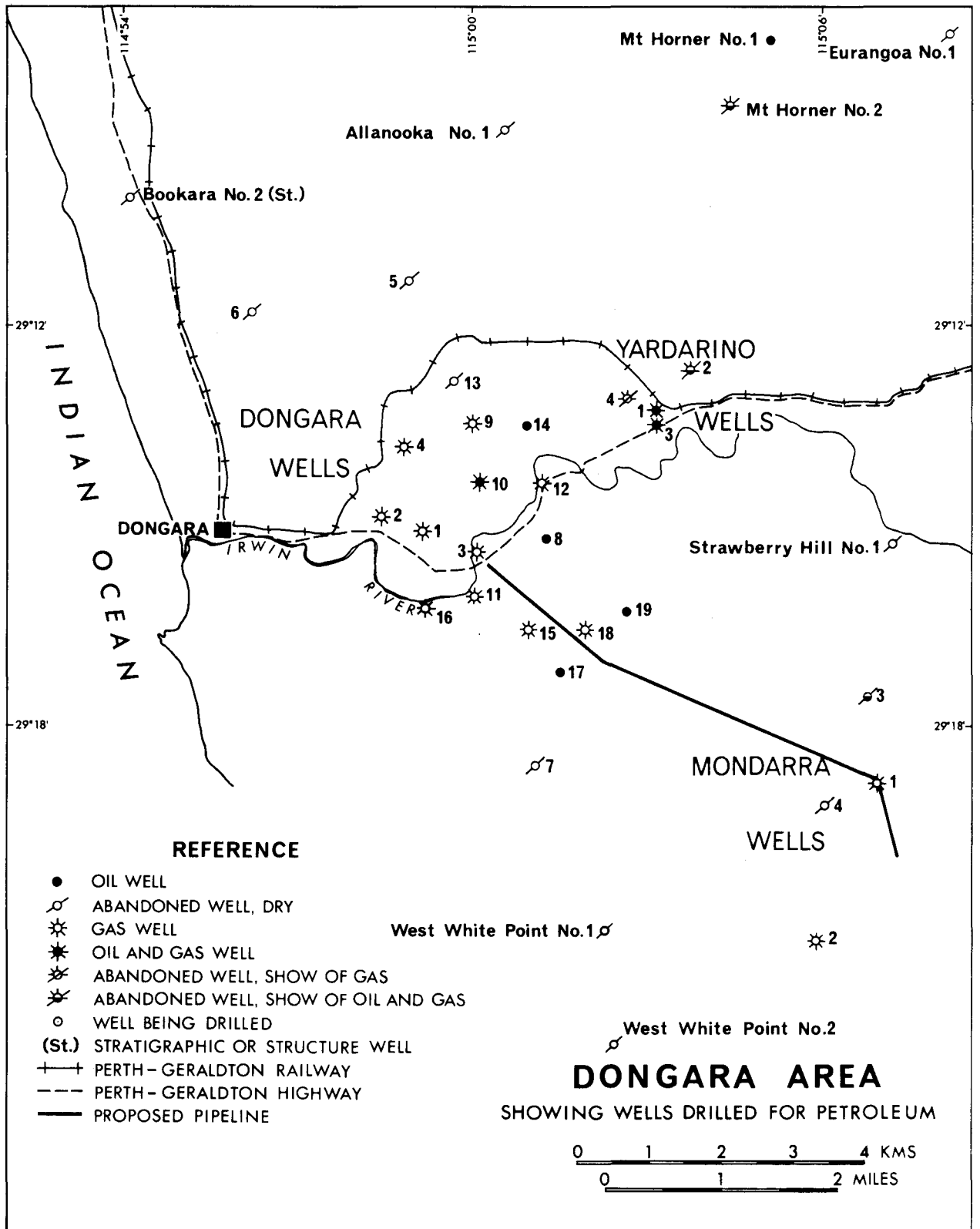
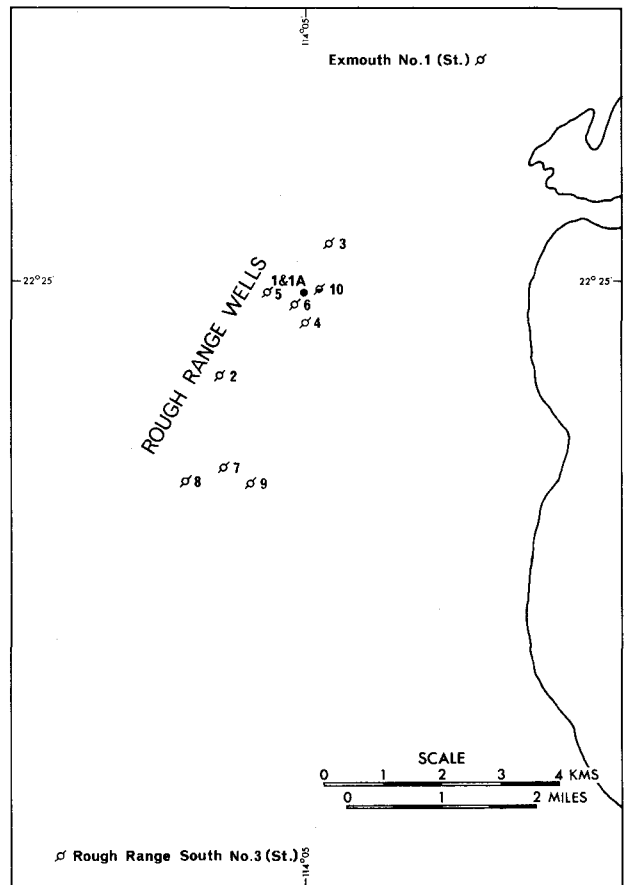
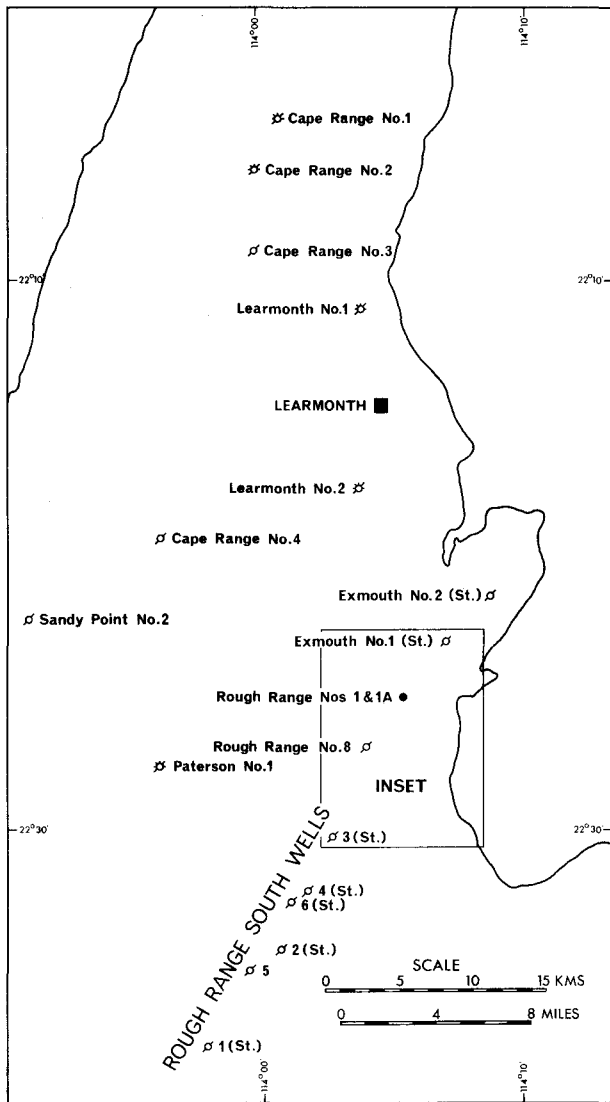


Figure 14.



● OIL WELL  
 ∅ ABANDONED WELL, DRY  
 ∅ ABANDONED WELL, SHOW OF OIL  
 ∅ ABANDONED WELL, SHOW OF GAS  
 (St.) STRATIGRAPHIC OR STRUCTURE WELL

**CAPE RANGE — ROUGH RANGE AREA**  
 SHOWING WELLS DRILLED FOR PETROLEUM

Figure 15.

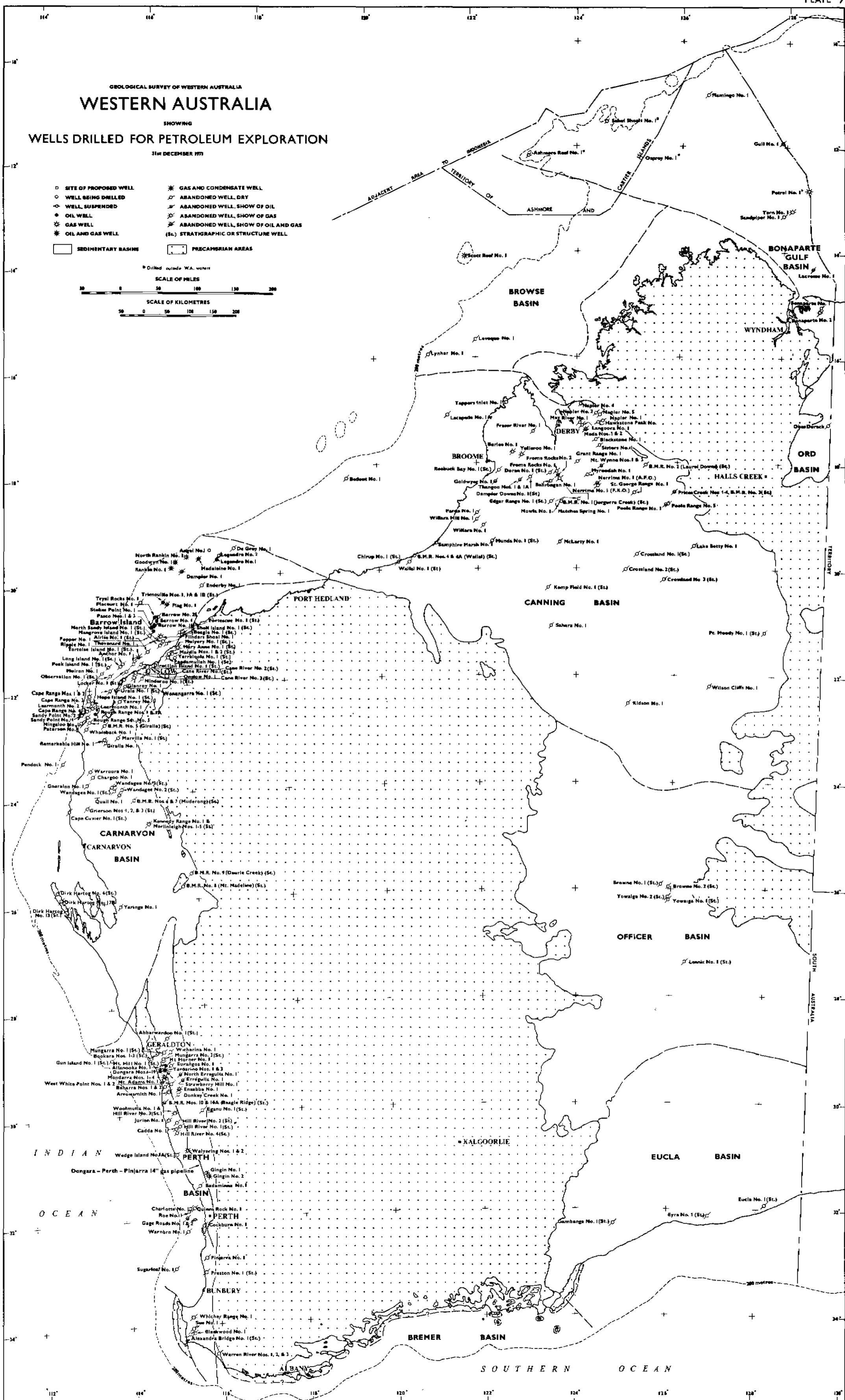
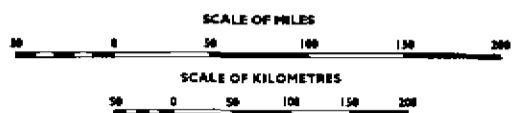
# GEOLOGICAL SURVEY OF WESTERN AUSTRALIA WESTERN AUSTRALIA

## SHOWING WELLS DRILLED FOR PETROLEUM EXPLORATION

31st DECEMBER 1977

- SITE OF PROPOSED WELL
- WELL BEING DRILLED
- WELL SUSPENDED
- OIL WELL
- ★ GAS WELL
- ★ OIL AND GAS WELL
- SEDIMENTARY BASINS
- PRECAMBRIAN AREAS
- ★ GAS AND CONDENSATE WELL
- ✂ ABANDONED WELL, DRY
- ✂ ABANDONED WELL, SHOW OF OIL
- ✂ ABANDONED WELL, SHOW OF GAS
- ✂ ABANDONED WELL, SHOW OF OIL AND GAS
- (St.) STRATIGRAPHIC OR STRUCTURE WELL

Drilled outside W.A. waters





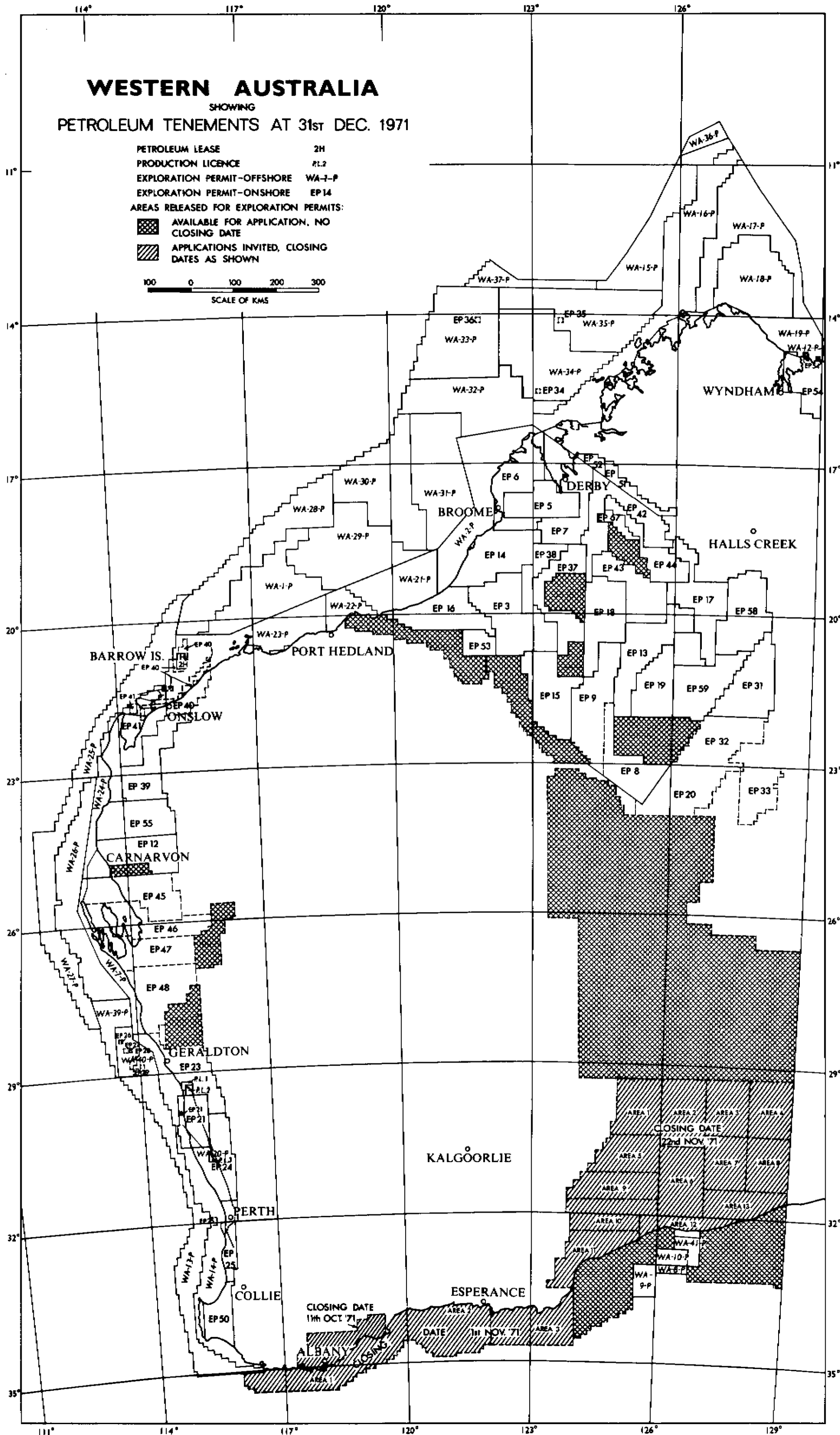
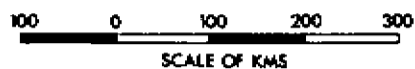
# WESTERN AUSTRALIA

SHOWING  
PETROLEUM TENEMENTS AT 31st DEC. 1971

- PETROLEUM LEASE 2H
- PRODUCTION LICENCE P.L.2
- EXPLORATION PERMIT-OFFSHORE WA-1-P
- EXPLORATION PERMIT-ONSHORE EP 14

AREAS RELEASED FOR EXPLORATION PERMITS:

-  AVAILABLE FOR APPLICATION, NO CLOSING DATE
-  APPLICATIONS INVITED, CLOSING DATES AS SHOWN



*Production Licences*

Number	No. of grati-cular sections	Expiry date of current term	Registered holder
PL 1	5	24/10/92	West Australian Petroleum Pty. Ltd.
PL 2	4	24/10/92	" " " " " "
PL 3	5	24/10/92	" " " " " "

**PETROLEUM TENEMENTS UNDER THE PETROLEUM PIPELINES ACT, 1969**

*Pipeline Licences*

Number	Expiry date of current term	Registered holders
1	1/12/91	California Asiatic Oil Co., Texaco Overseas Petroleum Co., Shell Development (Australia) Pty. Ltd., Ampol Exploration Ltd.
2	1/12/91	" " " " " " " " "
3	1/12/91	" " " " " " " " "

**DRILLING**

The positions of wells drilled for petroleum exploration in Western Australia to the end of 1971 are shown on Plate 8, Figures 14 and 15. Details relating to the wells drilled during the year are given in Table 1.

A summary of the principal results of drilling in each basin is as follows:

**PERTH BASIN**

The offshore drilling programme that commenced during 1970 was completed in 1971, with the drilling of four wells. The primary objective in each was the Lower Cretaceous sequence, but all wells were dry. Four onshore wells were drilled in the basin, one of which, Walyering No. 1, discovered a new gas field in the Lower Jurassic Cockleshell Gully Formation. The other wells were dry. Unfortunately the sandstone reservoirs in the Cockleshell Gully Formation are very variable and discontinuous as shown by the Walyering No. 2 extension test well, which was abandoned as it yielded only uneconomic gas flows.

Walyering No. 1 gave a flow of 382.3 x 10<sup>3</sup> cubic metres per day (13.5 MMCF/d) on a drill-stem test of the interval 3,368-3,397 metres (11,048-11,142 ft) through a ½-inch bottom choke and a ¾-inch surface choke. The well was completed as a gas producer over the perforated intervals 3,369-3,371 metres (11,050-11,056 ft), 3,376-3,379 metres (11,072-11,082 ft), 3,381-3,391 metres (11,090-11,122 ft) and 3,392-3,399 metres (11,125-11,150 ft). On a production test of these intervals the well flowed gas at 300.2 x 10<sup>3</sup> cubic metres per day (10.6 MMCF/d) with slugs of condensate on a ½-inch surface choke.

**CARNARVON BASIN**

A total of four offshore test wells was completed by the B.O.C. group during the year, three of which (North Rankin No. 1, Rankin No. 1, and Goodwyn No. 1) made large gas discoveries. Another offshore well, Angel No. 1, was still drilling at the end of the year, and strong hydrocarbon indications have been encountered in the Jurassic section. Two dry test wells were drilled onshore by Wapet, and two stratigraphic wells were completed by Hematite Petroleum Pty. Ltd. (under a farmout from Wapet), while another was still drilling at the end of the year.

After testing had been completed the North Rankin No. 1, Rankin No. 1, and Goodwyn No. 1 wells were plugged. Further drilling will be necessary to define the extent of the fields, but it seems likely that they will be found to contain major gas reserves and appreciable quantities of condensate. Some details of the wells are as follows:

**North Rankin No. 1**

The producing unit in North Rankin No. 1 is the Middle to Upper Triassic Mungaroo Formation; it is also the producing reservoir in Rankin No. 1 and Goodwyn No. 1. The sandstones in this formation have excellent reservoir characteristics, and the net pay thickness in North Rankin No. 1 amounts to 311 metres (1,020 ft). The gross hydrocarbon column extends from 2,688 to 3,252 metres (8,819 to 10,670 ft), a thickness of 564 metres (1,851 ft). The following is a summary of important drill-stem tests (on a ½-inch bottom choke):

D.S.T. No.	Interval (metres)	Surface Choke	Gas x 10 <sup>3</sup> m <sup>3</sup> /d	Condensate b/d
1	3,251-3,255	½"	235.0	95.5
2	3,207-3,210	½"	363.0	317
3	3,104-3,110	½"	388.2	384
4	3,011-3,015	½"	346.3	235
5	2,837-2,841	½"	387.9	298
6	2,573-2,584	1½"	0.2	....

**Rankin No. 1**

The producing unit in Rankin No. 1 is the Mungaroo Formation. The sandstones are not as good reservoirs as in North Rankin No. 1, and the net pay thickness of gas/condensate is 62.8 metres (206 ft) with a 3.4-metre (11 ft) thick oil column (40° API gravity). The water contact lies at a depth of 2,955 metres (9,694 ft). The following is a summary of the two drill-stem tests run in the hole (on a ¾-inch bottom choke):

D.S.T. No.	Interval (metres)	Surface choke	Gas x 10 <sup>3</sup> m <sup>3</sup> /d	Condensate b/d	Oil b/d
1	2,952-2,953.5	¾"	308.9	....	1,062
2	2,933-2,939	¾"	451.9	564	....

**Goodwyn No. 1**

The Mungaroo Formation is also the producing unit in Goodwyn No. 1. There are some 78 metres (255 ft) net of gas/condensate sands from 2,797 metres (9,175 ft) to about 3,168 metres (10,390 ft). The following is a summary of the two drill-stem tests run in the hole (on a ¾-inch bottom choke):

D.S.T. No.	Interval (metres)	Surface choke	Gas x 10 <sup>3</sup> m <sup>3</sup> /d	Condensate b/d
1	2,842-2,848	¾"	322.8	490
2	3,147-3,152	¾"	215.2	347

**CANNING BASIN**

During the year one offshore test well, two onshore test wells, and four onshore stratigraphic wells were drilled in the Canning Basin. All were abandoned as dry holes. The offshore well, Bedout No. 1, penetrated a Tertiary and Mesozoic sequence comparable with that known from the northern Carnarvon Basin, and bottomed in basalt of Triassic or older age. It was the first well to be drilled in the Bedout sub-basin.

**BROWSE BASIN**

Two wells, Lynher No. 1 and Scott Reef No. 1, were drilled in the Browse Basin during 1971. Lynher No. 1 was dry, but Scott Reef No. 1 made a substantial discovery of gas and condensate. It was put down by the B.O.C. group in the lagoon of Scott Reef, a large coral atoll 280 kilometres (175 miles) off the Kimberley coast, and is the deepest offshore well drilled to date in Australia. Production was obtained from Lower to Middle Jurassic and Upper Triassic sandstones and carbonates, the net pay thickness being some 50 metres (170 ft) between 4,294 and 4,387 metres (14,085 and 14,390 ft). After testing had been completed the well was plugged. The company has conducted feasibility studies into the possibility of building a liquified natural gas plant on Sandy Island, which forms part of the atoll.

TABLE 1. WELLS DRILLED FOR PETROLEUM EXPLORATION IN WESTERN AUSTRALIA DURING 1971

Basin	Well	* = Subsidized	Concession	Operating Company	Type	Position		Elevation and water depth (in metres)			Dates			Total depth (or depth reached) in metres	Bottomed in	Status on 31 Dec. 71
						Latitude South	Longitude East	G.L.	D.F.	W.D.	Com-menced	Reached T.D.	Com-pleted			
Perth	Charlotte No. 1	*	WA-14-P	WAPET	NFW	31 48 36	115 26 56	....	30.2	42.1	19/12/70	8/1/71	11/1/71	2,435	U. Jurassic	P & A
	Gage Roads No. 2	*	WA-13-P	WAPET	NFW	31 57 05	115 21 45	....	30.2	73.2	14/1/71	9/2/71	12/2/71	2,972	U. Jurassic	P & A
	Sugarloaf No. 1	*	WA-13-P	WAPET	NFW	32 54 54	115 03 08	....	30.2	46.0	14/2/71	7/4/71	11/4/71	3,658	U. Jurassic	P & A
	Walyering No. 1	*	EP-24	WAPET	NFW	30 42 57	115 27 55	94.5	99.1	....	31/1/71	10/4/71	6/5/71	3,643	L. Jurassic	Gas well
	Walyering No. 2	*	EP-24	WAPET	EXT	30 42 08	115 28 20	100.3	104.9	....	24/6/71	24/10/71	25/12/71	4,115	L. Jurassic	Gas shows
	Warnbro No. 1	*	WA-14-P	WAPET	NFW	32 14 20	115 20 45	....	24.1	47.5	26/11/70	2/1/71	10/1/71	3,661	U. Jurassic	P & A
	West White Point No. 1	*	EP-23	WAPET	STR	29 20 42	115 02 23	76.2	80.2	....	1/2/71	26/2/71	27/2/71	2,248	Permian	P & A
West White Point No. 2	*	PL-2	WAPET	NFW	29 22 44	115 02 24	32.3	36.3	....	27/11/71	28/12/71	30/12/71	2,350	Permian	P & A	
Carnarvon	Angel No. 1	*	WA-1-P	B.O.C.	NFW	19 30 20	116 35 48	....	9.4	79.9	12/10/71	....	....	3,240	Carboniferous	Drilling
	Cane River No. 1	*	EP-40	HEMA-TITE	STR	21 40 56	115 05 54	7.6	10.4	....	29/11/71	11/12/71	11/12/71	696	Carboniferous	P & A
	Cane River No. 2	*	EP-40	HEMA-TITE	STR	21 38 13	115 15 51	4.6	7.3	....	17/12/71	23/12/71	23/12/71	413	Pre-Cretaceous	P & A
	Cane River No. 3	*	EP-40	HEMA-TITE	STR	21 42 28	115 19 29	14.9	17.7	....	29/12/71	....	....	69	Pre-Cretaceous	Drilling
	De Grey No. 1	*	WA-1-P	B.O.C.	NFW	19 29 21	117 05 08	....	30.5	94.5	10/9/71	16/10/71	18/10/71	2,088	Triassic	P & A
	Goodwyn No. 1	*	WA-28-P	B.O.C.	NFW	19 41 37	115 53 44	....	30.5	125.6	22/10/71	26/11/71	14/12/71	3,536	Triassic	Gas discovery
	Ningaloo No. 1	*	EP-41	WAPET	NFW	22 34 25	113 46 40	103.9	107.9	....	18/3/71	6/4/71	8/4/71	1,228	Jurassic	P & A
	North Rankin No. 1	*	WA-28-P	B.O.C.	NFW	19 35 55	116 07 30	....	30.5	122.2	5/5/71	25/6/71	26/7/71	3,534	Triassic	Gas discovery
Rankin No. 1	*	WA-28-P	B.O.C.	NFW	19 47 56	115 44 31	....	9.4	93.0	31/7/71	23/9/71	8/10/71	4,111	Triassic	Gas discovery	
Sandy Point No. 2	*	EP-41	WAPET	NFW	22 22 15	113 50 42	99.1	102.7	....	17/4/71	5/5/71	6/5/71	1,680	L. Jurassic	P & A	
Canning	Bedout No. 1	*	WA-29-P	B.O.C.	NFW	18 14 40	119 23 23	....	30.5	141.7	31/7/71	4/9/71	7/9/71	3,073	Triassic or older	P & A
	Crossland No. 1	*	EP-43	WAPET	STR	19 43 10	125 14 50	181.0	183.8	....	31/7/71	16/8/71	17/8/71	913	?U. Devonian	P & A
	Crossland No. 2	*	EP-18	WAPET	STR	20 00 45	124 59 36	175.4	177.7	....	22/8/71	3/9/71	4/9/71	914	?Silurian	P & A
	Crossland No. 3	*	EP-13	WAPET	STR	20 12 12	125 45 39	230.7	233.5	....	24/9/71	15/10/71	16/10/71	915	U. Devonian	P & A
	Lake Betty No. 1	*	EP-17	WAPET	NFW	19 34 11	126 19 53	271.6	276.1	....	1/9/71	2/12/71	15/12/71	3,146	Devonian	P & A
	Munda No. 1	*	EP-3	WAPET	STR	19 28 27	122 17 33	94.2	97.2	....	5/11/71	18/11/71	19/11/71	1,067	?Silurian	P & A
	Tappers Inlet No. 1	*	EP-6	WAPET	NFW	16 51 38	122 35 22	18.9	21.9	....	16/6/71	5/8/71	10/8/71	2,856	Precambrian	P & A



Basin	Well	* = Subsidized	Concession	Operating Company	Type	Position		Elevation and water depth (in metres)			Dates			Total depth (or depth reached) in metres	Bottomed in	Status on 31 Dec. 71
						Latitude South	Longitude East	G.L.	D.F.	W.D.	Com-menced	Reached T.D.	Com-pleted			
Browse	Lynher No. 1	*	WA-32-P	B.O.C.	NFW	15 56 24	121 04 59	....	9.4	57.9	25/12/70	11/2/71	16/2/71	2,725	U. Permian	P & A
	Scott Reef No. 1	*	WA-33-P	B.O.C.	NFW	14 04 34	121 49 29	....	9.4	49.7	18/2/71	26/5/71	9/6/71	4,731	U. Triassic	Gas discovery P & A
Bonaparte Gulf	Flamingo No. 1		WA-16-P	ARCO	NFW	11 01 34	126 28 55	....	34.4	96.0	4/8/71	1/12/71	6/12/71	3,700	Jurassic	P & A
	Gull No. 1		WA-17-P	ARCO	NFW	11 56 29	127 54 37	....	13.1	134.4	5/6/70	15/1/71	19/1/71	3,422	Triassic	P & A
	Sandpiper No. 1		WA-18-P	ARCO	NFW	13 18 53	127 58 35	....	13.1	86.6	7/8/71	8/9/71	11/9/71	1,891	?U. Devonian	P & A
	Tern No. 1		WA-18-P	ARCO	NFW	13 13 15	128 03 53	....	13.1	93.9	26/1/71	5/7/71	4/8/71	4,352	L. Permian	Gas shows P & A
													Total	79,382		
													Less drilling done in 1970	8,762		
													Total drilling in 1971	70,620		

Arco = Arco Australia Ltd.  
 B.O.C. = B.O.C. of Australia Ltd.  
 Hematite = Hematite Petroleum Pty. Ltd.  
 WAPET = West Australian Petroleum Pty. Ltd.  
 NFW = New field wildcat well  
 STR = Stratigraphic well  
 EXT = Extension test well  
 P & A = Plugged and abandoned

The following is a summary of drill-stem tests conducted on the well (through a 3/8-inch bottom choke):

D.S.T No.	Interval (metres)	Surface choke	Gas x 10 <sup>3</sup> m <sup>3</sup> /d	Condensate b/d
1	{ 4,341-4,348 4,352-4,355 4,363-4,369 }	3/8"	226.5	....
2	as above, plus 4,381-4,384	1"	473.2	287
3	4,381-4,387	1"	300.2	196
4	4,300-4,306	1"	515.4	364

#### BONAPARTE GULF BASIN

Three wells were drilled by Arco during the year in the Bonaparte Gulf Basin in Western Australian waters. All were abandoned as dry holes, but there were some small gas flows in Tern No. 1.

### GEOPHYSICAL SURVEYS

#### SEISMIC

During 1971, seismic surveys were conducted in the Perth, Carnarvon, Canning, Browse, Bonaparte Gulf, and Eucla Basins. Details are as follows:

#### SEISMIC SURVEYS

Basin	Permit No.	Company	Line Kilometres marine	land
Perth	EP 21	West Australian Petroleum Pty. Ltd.	....	147.6
"	EP 23	" " " "	....	37.9
"	EP 24	" " " "	....	669.0
"	EP 25	" " " "	....	29.5
"	WA-13-P	" " " "	572.0	....
"	WA-14-P	" " " "	267.7	....
"	WA-20-P	" " " "	20.2	....
"	WA-40-P	BP Petroleum Dev. Aust. Pty. Ltd.	301.9	....
Carnarvon	WA-1-P	B.O.C. of Australia Ltd.	1,590.4	....
"	WA-23-P	" " " "	1,611.5	....
"	WA-24-P	West Australian Petroleum Pty. Ltd.	394.8	....
"	WA-25-P	" " " "	1,293.1	....
"	WA-26-P	Endeavour Oil Co. N.L.	341.2	....
"	WA-26-P	Canadian Superior Oil (Aust.) Pty. Ltd.	3,979.7	....
Canning	EP 3	West Australian Petroleum Pty. Ltd.	....	304.2
"	EP 6	" " " "	....	20.1
"	EP 7	" " " "	....	59.0
"	EP 13	" " " "	....	138.1
"	EP 14	" " " "	....	173.2
"	EP 15	" " " "	....	40.2
"	EP 18	" " " "	....	87.5
"	EP 19	" " " "	....	69.5
"	EP 37	" " " "	....	14.0
"	EP 38	" " " "	....	26.0
"	EP 42	" " " "	....	213.0
"	EP 43	" " " "	....	264.8
"	EP 44	" " " "	....	391.3
"	EP 53	" " " "	....	55.8
"	WA-2-P	" " " "	1,369.2	....
"	WA-21-P	" " " "	1,339.2	....
"	WA-23-P	" " " "	709.2	....
"	WA-29-P	B.O.C. of Australia Ltd.	721.9	....
"	WA-30-P	" " " "	606.9	....
"	WA-31-P	" " " "	996.9	....
"	WA-32-P	" " " "	206.5	....
Browse	WA-33-P	B.O.C. of Australia Ltd.	940.3	....
"	WA-34-P	" " " "	266.5	....
"	WA-35-P	" " " "	829.3	....
"	WA-36-P	" " " "	49.7	....
"	WA-37-P	" " " "	43.6	....
Bonaparte	WA-15-P	Arco Australia Ltd.	553.2	....
"	WA-16-P	" " " "	83.3	....
"	WA-17-P	" " " "	183.5	....
"	WA-18-P	" " " "	382.6	....
"	WA-19-P	" " " "	221.6	....
Eucla	Access Authority No. 1 S.L.	Hartogen Explorations Pty. Ltd.	56.3	....
Totals			19,933	2,744

### GRAVITY

Gravity surveys were carried out during the year in the Perth, Carnarvon, and Canning Basins. Details are as follows:

#### GRAVITY SURVEYS

Basin	Permit No.	Company	Party months
Perth	EP 21	West Australian Petroleum Pty. Ltd.	0.53
"	EP 23	" " " "	0.13
"	EP 24	" " " "	2.43
"	EP 25	" " " "	0.1
Carnarvon	EP 46	Oceania Petroleum Pty. Ltd.	1
"	EP 47	" " " "	2
"	EP 48	" " " "	1
Canning	EP 3	West Australian Petroleum Pty. Ltd.	1.1
"	EP 6	" " " "	0.07
"	EP 7	" " " "	0.21
"	EP 13	" " " "	0.5
"	EP 14	" " " "	0.63
"	EP 15	" " " "	0.14
"	EP 18	" " " "	0.31
"	EP 19	" " " "	0.25
"	EP 37	" " " "	0.05
"	EP 38	" " " "	0.09
"	EP 42	" " " "	0.77
"	EP 43	" " " "	0.96
"	EP 44	" " " "	1.42
"	EP 53	" " " "	0.21
Total			13.9

#### MAGNETOMETER

Aeromagnetic surveys were conducted in the Canning Basin, and ship-board magnetometer surveys in the Perth, Carnarvon, and Canning Basins. Details are as follows:

#### MAGNETOMETER SURVEYS

Basin	Permit No.	Company	Line Kilometres aeromag-	ship-board
Canning	WA-2-P	West Australian Petroleum Pty. Ltd.	....	1,730.4
"	WA-21-P	" " " "	....	1,339.2
"	WA-23-P	" " " "	....	579.3
"	EP 31, 32, 33	Australian Aquitaine Petroleum Pty. Ltd.	4,127.8	....
"	EP 58	Associated Australian Oilfields N.L.	6,276.2	....
"	EP 59	" " " "	5,723.9	....
Perth	WA-13-P	West Australian Petroleum Pty. Ltd.	....	943.5
"	WA-14-P	" " " "	....	280.2
"	WA-20-P	" " " "	....	40.3
Carnarvon	WA-26-P	Canadian Superior Oil (Aust.) Pty. Ltd.	....	1,515.9
"	WA-24-P	West Australian Petroleum Pty. Ltd.	....	394.3
"	WA-25-P	" " " "	....	1,278.2
Totals			16,133	8,101

### GEOLOGICAL SURVEYS

Field geological investigations were carried out by oil exploration tenement holders in the Perth and Canning Basins. Details are as follows:

Basin	Permit No.	Company	Geologist months
Perth	EP 21	West Australian Petroleum Pty. Ltd.	2.0
Canning	EP 32	Australian Aquitaine Petroleum Pty. Ltd.	1.5
"	EP 33	" " " "	1.5
"	EP 51	Lennard Oil N.L.	0.5
"	EP 52	" " " "	0.5
"	EP 17	West Australian Petroleum Pty. Ltd.	0.75
"	EP 42	" " " "	0.75
"	EP 58	Associated Australian Oilfields N.L.	5.0
"	EP 59	" " " "	1.0
Total			13.50

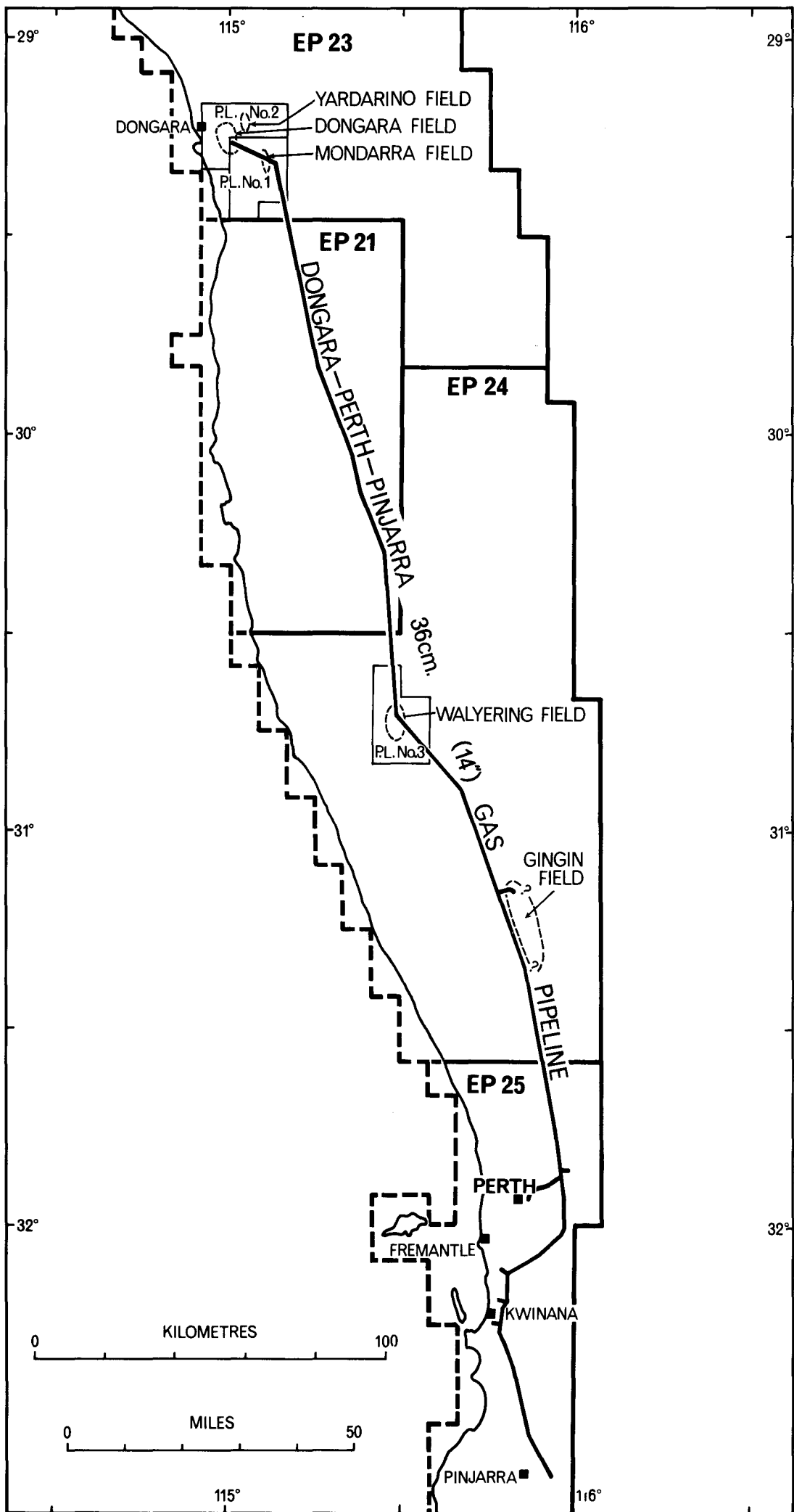


Figure 16. The Dongara-Perth-Pinjarra Gas Pipeline.

# PETROLEUM DEVELOPMENT AND PRODUCTION IN WESTERN AUSTRALIA IN 1971

by R. N. Cope

## ABSTRACT

Western Australia has, at present, two producing fields: the Barrow Oilfield and the Dongara Gasfield. The Barrow Field has passed a maximum production of 49,803 barrels per day in September 1970, average daily production in December 1971 being 43,617 barrels per day. By means of a water-flood secondary-recovery scheme a total production of 16,213,561 barrels was achieved during 1971. Gas produced amounted to  $325,099 \times 10^3$  cubic metres (11,480,683 MMCF) of which about 95 per cent was flared.

Production of gas from the Dongara Field started on 25th October 1971. A total of  $34,794 \times 10^3$  cubic metres (1,228,759 MMCF) was produced during 1971 and transmitted via the 415-kilometre (258 mile) long 36-centimetre (14 in) diameter gas pipeline to consumers in Perth and Kwinana. This pipeline was diverted to run through the Walyering Field and a spur was constructed to Gingin No. 1. Further drilling and testing will be necessary to determine the economic potential of these two fields.

## INTRODUCTION

Both the Barrow Oilfield and the Dongara Gasfield are fully developed for present production requirements and no development drilling took place in 1971. Following the discovery of gas in Walyering No. 1 (see p. 39) a second well was drilled to appraise the structure, but this was abandoned as uncommercial. Although four major gas strikes were made offshore in 1971 at Scott Reef No. 1,

North Rankin No. 1, Rankin No. 1 and Goodwyn No. 1 (p. 39) no development of these fields has so far been undertaken.

Production figures quoted in the text are given in thousands of cubic metres per day ( $\times 10^3 \text{m}^3/\text{d}$ ) and millions of cubic feet per day (MMCF/d). Oil and condensate production is quoted in barrels only, as the barrel has international acceptance as the standard volumetric unit in the petroleum industry. Oil production figures in countries using the metric system are also generally quoted in metric tons, and the conversion factor from barrels varies according to the gravity of the oil or condensate. For Barrow Island crude this factor is approximately 7.5 bbl/metric ton.

## BARROW ISLAND OILFIELD

The Barrow Island Oilfield (Fig. 1) was discovered by Wapet in 1964 and the first oil shipment took place in 1967. Appraisal and development were completed in July, 1970, after the drilling of some 517 wells of which 502 have been used for production (Cope, 1970, Plate 13). The maximum production rate was achieved in September 1970 with an average of 49,803 barrels per day. During 1971, oil production declined slightly from 46,940 barrels per day in December, 1970, to 43,617 barrels per day in December, 1971. A total of 16,213,561 barrels was produced in 1971 compared with 16,693,169 barrels in 1970 (Table 1). Original reserves are stated by Wapet to be 200 million barrels of recoverable oil producible by primary and secondary methods, so that remaining reserves at 31st December, 1971 were about 138 million barrels.

TABLE 1. BARROW ISLAND OIL AND GAS PRODUCTION

Reservoir	Average daily production oil (bbls) December, 1971	Production for year 1971			Cumulative production		
		Oil (bbls)	Water (bbls)	Gas $\times 10^3 \text{m}^3$	Oil (bbls)	Water (bbls)	Gas $\times 10^3 \text{m}^3$
Windalia	42,653	15,821,808	3,516,324	277,372	60,081,407	5,754,854	1,158,248
Munderong	663	239,506	37,778	6,064	691,189	115,273	16,617
Jurassic 5,500'	0	2,907	52,252	4,588	15,580	101,628	14,621
Jurassic 6,200'	2	8,942	46,039	21,827	54,126	110,429	71,783
Jurassic 6,600'	67	27,472	73,347	1,879	209,295	275,340	16,871
Jurassic 6,700'	232	112,926	45,734	13,369	952,648	204,373	74,146
Total field	43,617	16,213,561	3,771,474	325,099	62,004,245	6,561,897	1,352,286

Water injected : 42,751,878 bbls  
NOTE : 1 barrel = 0.15899  $\text{m}^3$   
1  $\text{m}^3$  = 35.315 cu ft

Cumulative water injected : 98,473,275 bbls

The main reservoir is the Lower Cretaceous "Windalia Sand" (Parry, 1967) below which there are five minor sand reservoirs. At the end of 1971 the "5,500' sand" was no longer producing. The "Windalia Sand" is characterized by high porosity (25-32 per cent) and low permeability (several

millidarcies on average) owing to the fine to very fine grain size (Burdett and others, 1970). A water-flood secondary-recovery scheme is in operation to flood this reservoir more effectively (Table 2) and during 1971 the pumping capacity was increased by about 5 per cent.

TABLE 2. BARROW ISLAND WELL STATUS BY RESERVOIRS AT 31st DECEMBER, 1971

Reservoir	Flowing	Pumping	Gas lift	Non-producing	Water injection wells	Injection source wells	Total
Windalia	37	135	142	9	153	9	485
Munderong	3	2	3	....	....	....	8
Jurassic 5,500'	....	....	....	1	....	....	1
Jurassic 6,200'	1	....	....	1	....	....	2
Jurassic 6,600'	1	....	....	....	....	....	1
Jurassic 6,700'	1	1	2	1	....	....	5
Total	43	138	147	12	153	9	502

Of the 325,099 x 10<sup>3</sup> cubic metres (11,480.883 MMCF) of gas produced during 1971, 5.1 per cent or 16,644 x 10<sup>3</sup> cubic metres (587.773 MMCF) was used as pump fuel and for artificial gas lift, the remainder being flared (Table 3).

TABLE 3. BARROW ISLAND OIL AND GAS DISPOSAL, 1971

	Oil (bbls)	Gas x 10 <sup>3</sup> m <sup>3</sup>
Total production	16,213,561	325,099
Field fuel	nil	16,644
Gas flared	....	308,455
Oil shipments	16,352,920	....
Percentage of field utilization	....	5.1
Percentage of gas flared	....	94.9
Royalty received	\$1,721,804.27	....

NOTE: 1 m<sup>3</sup>=35.315 cu ft

#### DONGARA GASFIELD

The Dongara gas pool in Lower Triassic and Lower Permian sandstones was discovered in 1966. The completion, in 1970, of appraisal and development drilling established reserves in the order of 14.16 x 10<sup>9</sup> cubic metres (500,000 MMCF) of gas in the Dongara area and indicated the presence of a thin oil leg in the Dongara Field. The stratigraphy of the reservoir and the depositional history of the sequence in which it occurs have now been reconstructed in some detail (Hosemann, 1971; Bird and others, 1971).

During 1971, a 415-kilometre (258 mile) long 36-centimetre (14 in) diameter gas pipeline was built between Dongara and Pinjarra via Perth and Kwinana (Fig. 16). Dongara Field Production Licences Nos. 1 and 2 were issued on 25th October 1971, on which day production also commenced. Details of total production and royalty paid until 31st December 1971 are given in Table 4.

TABLE 4. DONGARA GAS AND CONDENSATE PRODUCTION, 1971

Production	Gas x 10 <sup>3</sup> m <sup>3</sup>	Condensate (bbls)	Water (bbls)
Total for year	34,794	1,243.7	Nil
Average daily during December	729	25	Nil

Number of producing wells at 31/12/71 : 8  
Royalty paid in respect of 1971 production : \$7,937.94  
NOTE: 1 m<sup>3</sup>=35.315 cu ft 1 bbl=0.15899 m<sup>3</sup>

Total throughput and sales are scheduled to reach 1,980 x 10<sup>3</sup> cubic metres (70 MMCF) per day during 1972 under contractual agreements. The pipeline was slightly diverted and lengthened from the originally planned route to pass through the Walyering Field, over which Production Licence No. 3 was also issued on 25th October 1971 (Fig. 16). A 10.2-centimetre (4 in) diameter spur has been constructed to Gingin No. 1 to allow experimental production into the pipeline under temporary special arrangements with the State Government.

#### REFERENCES

- Bird, K. J., Coleman, W. F., and Crocker, H., 1971, The depositional history of a portion of the North Perth Basin—a single well dipmeter analysis: Australia Petrol. Expl. Assoc. Jour., p.90-94.
- Burdett, J. W., Parry, J. C., and Willmott, S.P., 1970, Evaluation of the Windalia Sand, Barrow Island, an empirical approach: Australia Petrol. Expl. Assoc. Jour. p. 91-96.
- Copps, R. N., 1971, Petroleum development and production in Western Australia in 1970: West. Australia Geol. Survey Ann. Rept. 1970 p. 31-32.
- Hosemann, P., 1971, The stratigraphy of the basal Triassic sandstone, North Perth Basin, Western Australia: Australia Petrol. Expl. Assoc. Jour. p. 59-63.
- Parry, J. C., 1967, The Barrow Island Oilfield: Australia Petrol. Expl. Assoc. Jour., p. 130-133.

## DEFINITIONS OF SOME NEW AND REVISED ROCK UNITS IN THE PERTH BASIN

by P. E. Playford and G. H. Low

#### ABSTRACT

Formal definitions are given of the following six stratigraphic units from the Perth Basin of Western Australia: Sue Coal Measures (Permian), Yardeano Sandstone (Lower Triassic), Eneabba Member of the Cockleshell Gully Formation (Lower Jurassic), Maxicar Beds (probably Lower Cretaceous), Bassendean Sand (Pleistocene), and Safety Bay Sand (Recent). Another member of the

Cockleshell Gully Formation is redefined as the Cattamarra Coal Measures Member.

#### INTRODUCTION

Recent mapping and the results of exploratory drilling in the Perth Basin have shown a need for the formal naming of some new rock units. The purpose of this paper is to briefly describe these units.

## SUE COAL MEASURES

The name Sue Coal Measures is proposed for the Permian coal measures sequence encountered in the Sue No. 1, Whicher Range No. 1, Alexandra Bridge No. 1, and Blackwood No. 1 wells in the southern part of the Perth Basin. The type section is that in Sue No. 1 between 1,137 metres (3,730 ft) and 3,054 metres (10,021 ft), a total thickness of 1,917 metres (6,291 ft), and is described by Williams and Nicholls (1966). The formation consists of interbedded sandstone, clayey and carbonaceous siltstone, and seams of coal. A dolerite body (presumed to be a sill) intrudes the formation in Sue No. 1 between 2,862 metres (9,390 ft) and 2,869 metres (9,412 ft), and a similar intrusion was encountered in Blackwood No. 1. In Sue No. 1 the formation overlies Precambrian basement rocks and is overlain unconformably by Triassic sediments which probably correlate with the Lesueur Sandstone. The base of the formation was not reached in other wells, where it is overlain by Cretaceous, Jurassic, or Triassic sediments.

Seams of coal up to 5.5 metres (18 ft) in thickness occur in the formation. The coal is sub-bituminous and is similar in quality to Collie coal. However, the seams are not sufficiently close to the surface in any known occurrences to permit economic development.

Palynological study by B. E. Balme (*in* Williams and Nicholls, 1966) indicates that the formation ranges from Upper Permian to Lower Permian (Sakmarian) in age. It is thus equivalent to the whole of the sequence in the northern Perth Basin above the upper part of the Nangetty Formation. However, the Sue Coal Measures are entirely continental, in contrast to the mixed marine and continental sequence to the north. The Sue Coal Measures are correlated with the Collie Coal Measures and perhaps part of the Stockton Formation of the Collie and Wilga Basins.

## YARDARINO SANDSTONE

The name Yardarino Sandstone is proposed for the basal sandstone unit of the Triassic sequence in the Dongara-Yardarino-Mondarra area, where it forms an important petroleum reservoir. It rests with angular unconformity on Permian rocks and is overlain conformably by the Kockatea Shale. The formation consists of grey to brown-grey, medium to very coarse-grained sandstone, parts of which are clayey and conglomeratic. The type section is in Yardarino No. 1 well (29° 13' 13" S, 115° 03' 10" E) between 2,284 metres (7,496 ft) and 2,307 metres (7,570 ft), a total thickness of 23 metres (74 ft).

The Yardarino Sandstone was originally referred to as "Unit A" of the Wagina Sandstone (Upper Permian) by Pearson (1964). It was subsequently described by Hosemann (1971) as the "Basal Triassic Sandstone". Hosemann recognized three units within the formation, which he interpreted as near-shore marine and strand-line deposits.

The formation is recognized in the Dongara, Yardarino, Mondarra, Mount Horner, and Mungarra Wells, although it may not be continuous between them. The maximum known thickness is 58 metres (190 ft) in Dongara No. 19 well. A sandstone unit 1.5 metres (5 ft) thick beneath the Kockatea Shale at its type locality (near the mouth of Kockatea Gully) is tentatively correlated with the Yardarino Sandstone, but it is not a mappable unit in that area. Lenses of sandstone and conglomerate are also exposed at the base of the Kockatea Shale in the area east and north of Geraldton.

The only fossils found to date in the Yardarino Sandstone are spores, pollen grains, and microplankton, and these indicate that the unit is of Lower Triassic (Scythian) age (B. E. Balme, pers. comm., 1970).

## ENEABBA MEMBER

The name Eneabba Member is proposed for the lower member of the Cockleshell Gully Formation. It consists of multicoloured (red, yellow, brown, pink, purple, grey and white) fine to coarse-grained sandstone, with interbedded multicoloured claystone and siltstone. Some minor dark grey carbonaceous shale also occurs. The member has previously been referred to in company reports as the "Multicoloured Member". It overlies the Lesueur Sandstone with apparent conformity and is overlain conformably by the Cattamarra Coal Measures Member.

The type section of the Eneabba Member is in Eneabba No. 1 well between 2,302 metres (7,553 ft) and 2,978 metres (9,768 ft), a total thickness of 676 metres (2,215 ft). The unit is dated palynologically as Lower Jurassic (Balme, 1964). Microplankton occur in a few sections, indicating marine or paralic conditions, but most of the unit is believed to be continental.

## CATTAMARRA COAL MEASURES MEMBER

The name "Cattamarra Coal Member" was originally applied by Willmott (1964) to the coal-bearing unit within the Cockleshell Gully Formation, limited to the section between the highest and lowest coal seams. However, usage (for example Pearson, 1964) has established the "Coal Measures Member" for the coal-bearing unit from the top of the formation down to the first appearance of multicoloured sediments that characterize the Eneabba Member. Accordingly, it is now proposed that the term Cattamarra Coal Measures Member be formally applied to this unit.

The member is composed of very fine to very coarse-grained sandstone with interbedded grey shale and siltstone, in part carbonaceous, and containing beds of coal. The coal seams are strong seismic reflectors, which can be traced over a wide area. The name is taken from Cattamarra property in the Hill River area, and the type section is from 1,780 metres (5,874 ft) to 2,302 metres (7,553 ft) in Eneabba No. 1 well. The Cattamarra Coal Measures Member rests conformably between the Eneabba Member (below) and the Cadda Formation (above). It is of Lower Jurassic age and is apparently continental throughout.

## MAXICAR BEDS

The name Maxicar Beds was first used in an unpublished report by Lowry (1965) for exposures of ferruginous sandstone near Maxicar homestead, 19 kilometres (12 miles) north of Donnybrook (33° 24' 49" S, 115° 24' 49" E).

The unit consists of current-bedded ferruginous sandstone containing rare moulds of pelecypods. The sandstone is feldspathic, medium to coarse-grained, poorly sorted, and angular to subangular. The total thickness of the beds is unknown, but it is believed to be at least 9 metres (30 ft).

The stratigraphic relationships of the Maxicar Beds are uncertain. The type locality lies just east of the Darling Fault, and although the contact is not exposed, the unit is believed to lie directly on Archaean basement. The Maxicar Beds are exposed 13 kilometres (8 miles) north of the nearest outcrop of Donnybrook Sandstone, and they occupy the same position relative to the basin margin, suggesting that the two units may be laterally equivalent. The beds were included within the Donnybrook Sandstone by Playford and Willmott (1958).

A species of *Pterotrionia* was identified from the Maxicar Beds by J. M. Dickins (written comm., 1957), and he considered that this is of Jurassic or Cretaceous age. A lower Cretaceous dating now seems likely.

## BASSENDAN SAND

The name Bassendean Sand is proposed for a widespread unit of quartz sand extending over a large area of the coastal plain between the south coast and Hill River. It is named after Bassendean, a Perth suburb, where the formation is well represented, and this is regarded as the type area. The unit has been mapped in the Metropolitan Area by Low and others (1970).

The geomorphic unit represented by the exposed Bassendean Sand was named the Bassendean Dune System by McArthur and Bettenay (1960). The deposit occurs in a strip parallel to the coast, with its western edge generally about 5 kilometres (3 miles) inland. At the surface it appears as a series of quartz sand-hills which represent leached coastal dune limestones. Some remanent limestone is found along the western edge of the deposit from the Harvey Inlet to near Bunbury. The unit is strongly lateritized at the water table in the southern part of the Perth Basin.

No type section can be designated because of the poorness of vertical exposures through the unit. Western Titanium Limited's excavation for heavy minerals can be taken as a reference section, but this will be lost when the excavations are filled as part of the ground-restoration programme in the area. In the main heavy-mineral pit the base of the formation consists of a weathered boulder conglomerate of basalt and quartzite clasts, and this is interpreted as a beach deposit. It stands about 8 metres (25 ft) above present sea level and is overlain by about 8 metres (25 ft) of quartz sand containing high concentrations of heavy minerals. Elsewhere in the basin the maximum total thickness of the Bassendean Sand may exceed 45 metres (150 ft).

A ferruginized shell bed in the formation cropping out 8 kilometres (5 miles) southwest of Busselton contains numerous moulds of Quaternary molluscs.

The Bassendean Sand lies disconformably on the Pleistocene Guildford Formation or unconformably on Cretaceous rocks. It seems probable that the formation is of Middle to Late Pleistocene age.

## SAFETY BAY SAND

The name Safety Bay Sand was introduced in an unpublished thesis by Passmore (1967) for Recent coastal sand dunes and shallow-marine and strand-line sands in the Rockingham-Safety Bay area. The unit has now been applied to similar coastal sands throughout much of the Perth Basin. The sand is made up of shell fragments with varying amounts of quartz and minor feldspar. The cal-

cium carbonate content is normally more than 50 per cent. In some places the sand has been lithified to form calcarenite.

The type section of the Safety Bay Sand was designated by Passmore as that in the Rockingham Bore R3 (32° 16' 53" S, 115° 42' 19" E) from the surface to 24 metres (79 ft). Elsewhere the unit ranges up to about 30 metres (100 ft) above sea level. In most areas it overlies Pleistocene Coastal Limestone, but in the type section it rests on other Quaternary sands.

Fossils in the Safety Bay Sand are entirely living species, and deposition of the unit is continuing today.

## REFERENCES

- Balme, B. E., 1964, The Palynological record of Australian pre-Tertiary floras: *in* Ancient Pacific Floras, Univ. of Hawaii Press, p. 49-80.
- Hosemann, P., 1971, The stratigraphy of the Basal Triassic Sandstone, North Perth Basin, Western Australia: Australia Petrol. Expl. Assoc. Jour. v. 2, pt. 1, p. 59-63.
- Low, G. H., Lake, R. W., Doepel, J. J. G. and Baxter, J. L., 1970, Perth and environs geological maps, Sheets 1 to 4: West Australia Geol. Survey Pub. Perth Govt. Printer.
- Lowry, D. C., 1965, Geology of the southern Perth Basin: West Australia Geol. Survey Rec. 1965/17 (unpublished).
- McArthur, W. M., and Bettenay, E., 1960, The development and distribution of the soils of the Swan Coastal Plain, Western Australia: Australia CSIRO Soil Pub. no. 16.
- Passmore, J. R., 1967, The geology, hydrology, and contamination of shallow coastal aquifers in the Rockingham district, Western Australia: Univ. West. Australia Ph.D. Thesis (unpublished).
- Pearson, G. R., 1964, Yardarino No. 1 well completion report: West Australian Petroleum Pty. Ltd. P.S.S.A. Rept. (unpublished).
- Playford, P. E., and Willmott, S. P., 1958, Stratigraphy and structure of the Perth Basin, Western Australia: Rept. for West Australian Petroleum Pty. Ltd. (unpublished).
- Williams, C. T., and Nicholls, J., 1966, Sue No. 1 well completion report: West Australian Petroleum Pty. Ltd. P.S.S.A. Rept. (unpublished).
- Willmott, S. P., 1964, Revisions to the Mesozoic stratigraphy of the Perth Basin: Australia Bur. Mineral Resources P.S.S.A. Pub. 54, app. 1, p. 11-17.

# TECTONIC STYLE IN THE SOUTHERN PERTH BASIN

by R. N. Cope

## ABSTRACT

Geophysical surveys and drilling have shown that the depth of the southern Perth Basin is up to about 10,000 metres (30,000 ft). The basin is cut by numerous large faults, mainly of north-south trend. These are steep growth faults cutting basement, which moved during early Permian to early Cretaceous times. The gentle growth folds mapped at intermediate depths are interpreted as drape structures resulting from differential compaction over faulted basement highs.

An attempt to quantify total compaction of the Whicher Range No. 1 lithology results in an estimate of original depositional thickness two-thirds greater than the thickness of the present column. Compaction has probably continued since basement subsidence ceased, thus accommodating additional sediments, conceivably the entire Cretaceous sequence of the onshore Perth Basin.

An axis of uplift is recognized through the Blackwood Plateau and the name Jarrahwood Axis proposed. This axis was the prime control for the position of the Whicher Scarp formed by marine erosion during the Pleistocene.

## INTRODUCTION

In view of the great increase of subsurface data in the southern Perth Basin over the past 10 years, it is timely to consider the structural history and tectonic style in this part of the basin. The present paper deals with fault and fold geometry and fold origin. Mechanism of faulting requires wider study and this subject is deferred. Accurate topographic maps have recently been published covering the portion between 33° S and 34° S and these facilitate consideration of the Tertiary and

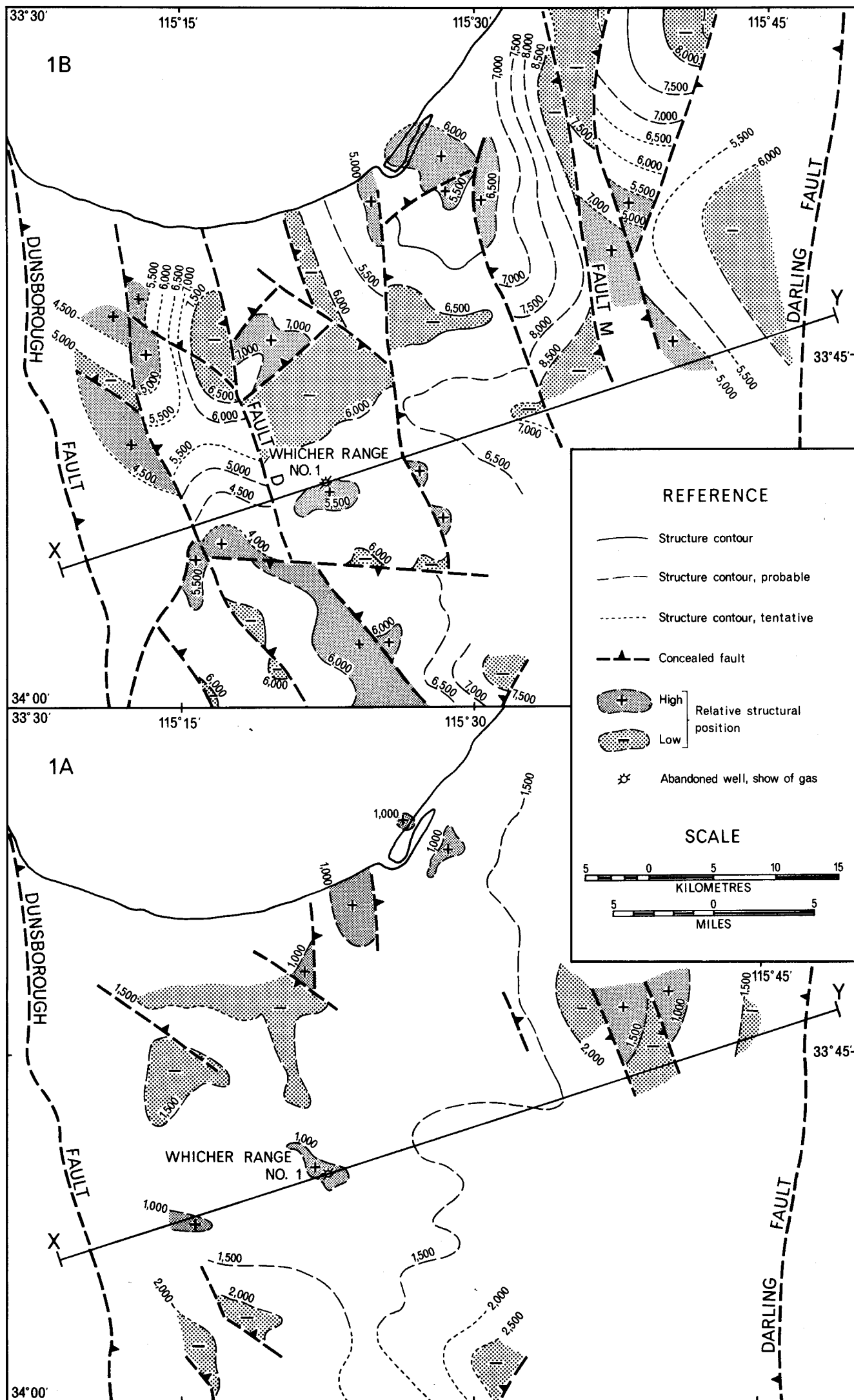


Figure 17. Structure contour maps. Contour interval 500 metres.  
 17A. Approximate base Middle Jurassic (horizon B of Aasted, 1969)  
 17B. Top basement (extapolated from horizon E of Aasted, 1969, and horizon C of Sealy, 1969.)



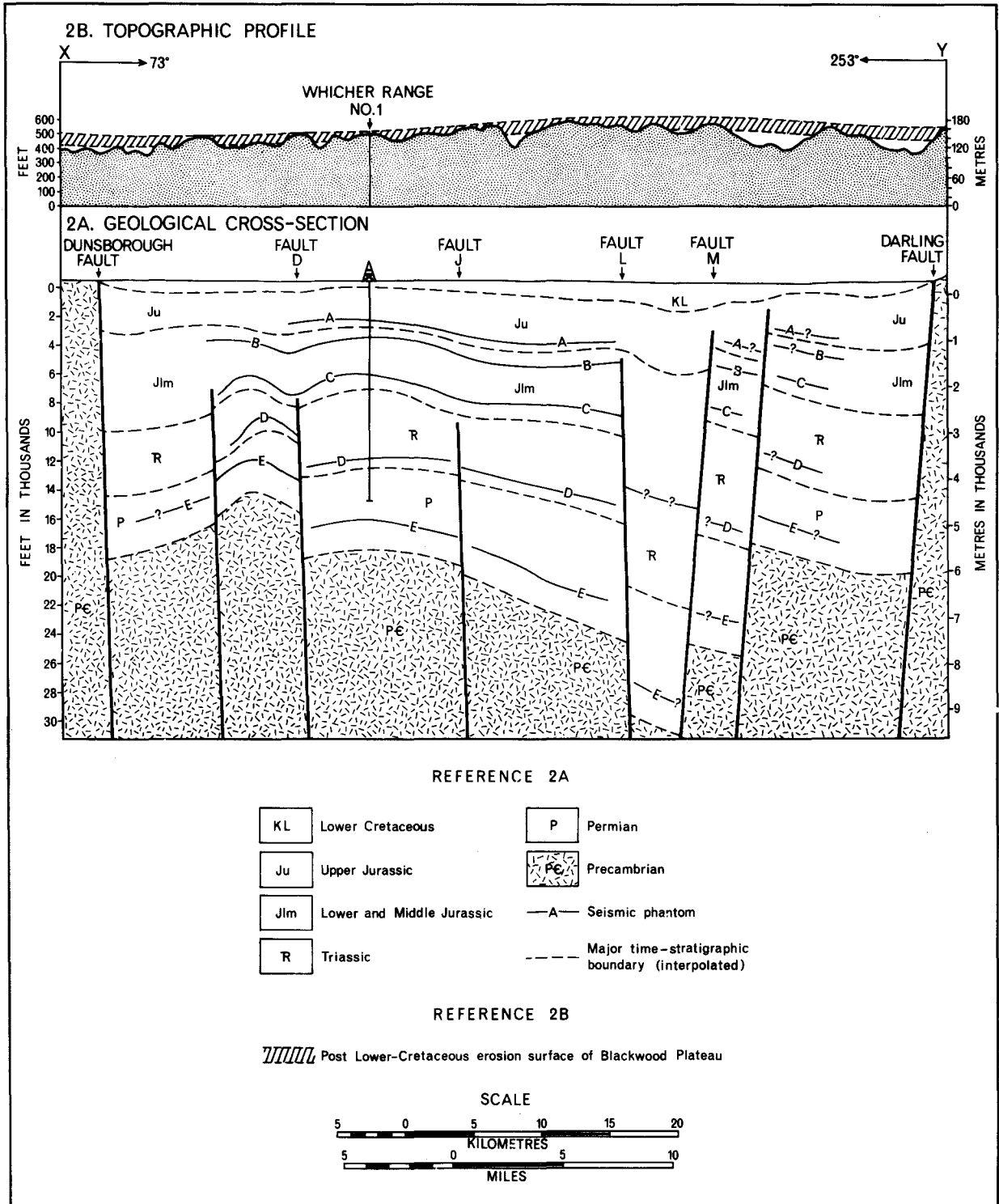
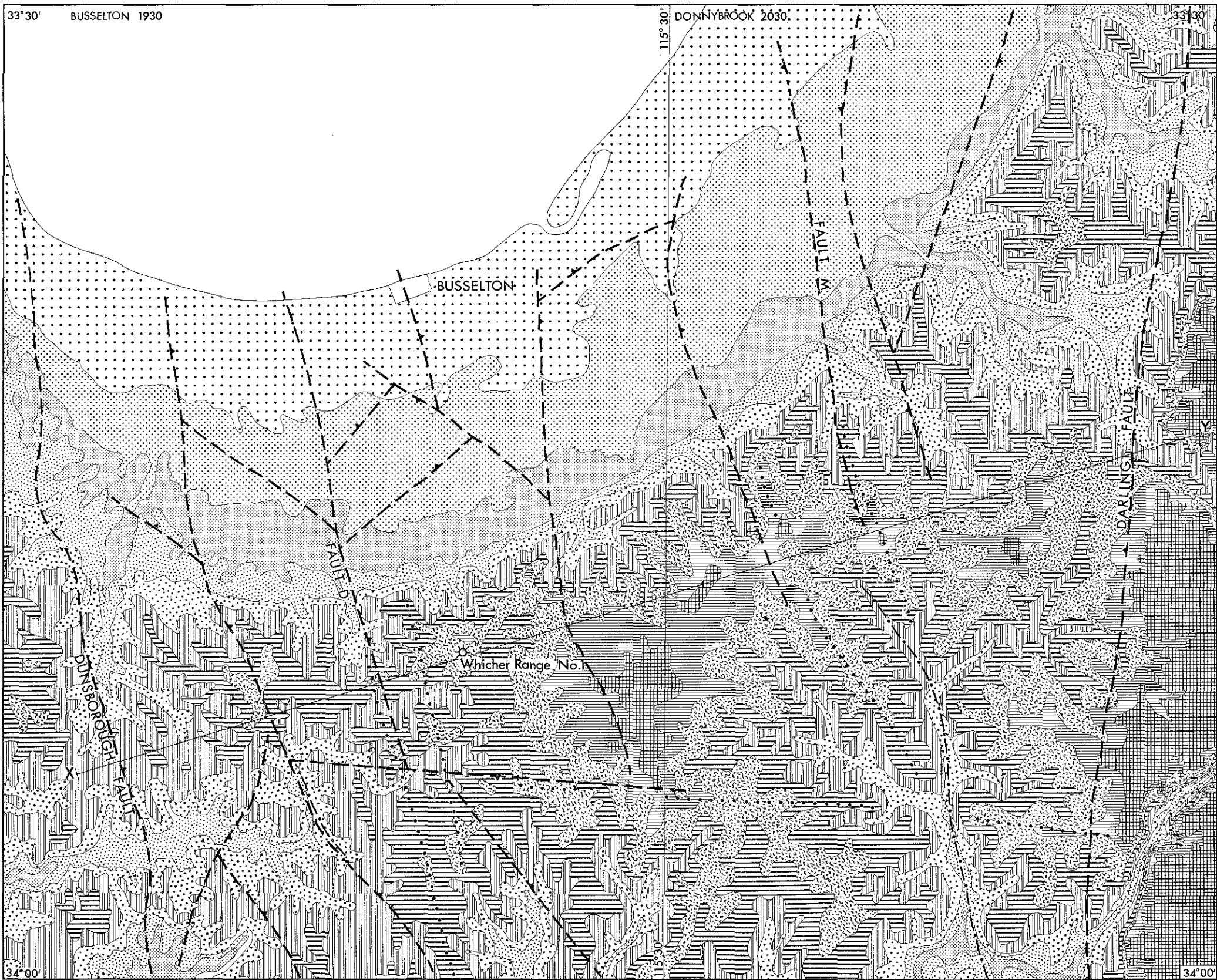


Figure 18. Cross sections through Whicher Range No. 1.

18A. Geological cross section based on Aasted, 1969, with geological boundaries interpolated from well data. Vertical exaggeration = 35x.

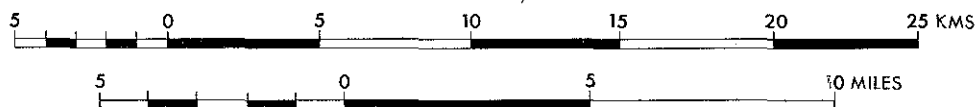
18B. Topographic profile showing dissected remnants of oldest post-Lower-Cretaceous erosion surface. Vertical exaggeration = 35x.



REFERENCE

	0 - 20 m		100 - 120 m
	20 - 40 m		120 - 140 m
	40 - 60 m		140 - 160 m
	60 - 80 m		160 - 180 m
	80 - 100 m		> 180 m

SCALE 1:250,000



SYMBOLS

- FAULT AT TOP BASEMENT LEVEL
- POSITIVE TOPOGRAPHIC LINEAMENT
- NEGATIVE TOPOGRAPHIC LINEAMENT
- SHEET NAME AND NUMBER OF 1:100,000 TOPOGRAPHIC SURVEY SERIES R 611

TOPOGRAPHIC CONTOURS IN THE PERTH BASIN  
BETWEEN LATITUDES 33° 30' AND 34° SOUTH

CONTOUR INTERVAL = 20 METRES UP TO 180 METRES

Quaternary geological history. The area considered here is that part of the onshore Perth Basin between 33° 30' S and 34° 20' S (Fig. 19, inset), forming part of the Bunbury Trough.

#### STATUS OF KNOWLEDGE

The maximum depth of Precambrian basement below sea level in the Bunbury Trough has now been established by various geophysical surveys (magnetic: Quilty, 1963; gravity: Thyer and Everingham, 1956; seismic: Sealy, 1969) as about 10,000 metres (30,000 ft). Depth is very variable, however, owing to numerous large faults. Whicher Range No. 1 was drilled to a total depth of 4,653 metres (15,266 ft) and is the deepest onshore well in the State to date (Union Oil, 1968). This well has revealed a predominantly sandy sequence deposited in a continuously continental environment from the Lower Permian to the Lower Cretaceous. No unconformities have conclusively been proved in this sequence but regional evidence suggests the probability of at least one, at the base of the Lower Cretaceous South Perth Formation (Upper Yarragadee of Union Oil, 1969). The only velocity contrasts are provided by thin shales and by Permian coal seams.

The latest seismic surveys (Aasted, 1969; Sealy, 1969) have produced what is believed to be a reasonably reliable picture of the regional subsurface structural forms, although owing to the absence of good seismic markers, rock-stratigraphic correlation across faults is not possible. This should be borne in mind when viewing the structure contour map (Fig. 17) and the Phanerozoic structure depicted in the cross section (Fig. 18).

Basement subsidence in the Perth Basin appears to have ended in the early Cretaceous, and following uplift some of the Lower Cretaceous strata have been removed by erosion. Owing to the absence of Upper Cretaceous and Tertiary deposits, the tectonic history during this interval can be studied only through the present geomorphology. The recently published 1:100,000 R611 topographic map series, of which the Bunbury, Busselton and Donnybrook Sheets are now available (Royal Australian Survey Corps, 1970), are ideal for this purpose. The 20-metre (66 ft) contours of those portions of the Busselton and Donnybrook Sheets underlain by Phanerozoic rocks are reproduced at a scale of 1:250,000 in Plate 9.

#### DISCUSSION

##### *Tectonic environment*

In considering the structural deformation of the sedimentary cover, the geometry and structural history of the top basement surface is of prime importance. During Phanerozoic times a quiet cratonic environment has prevailed in Western Australia. While cases of compressive tectonics do exist, for example in the Fitzroy Trough and the northern Carnarvon Basin, such occurrences are rare. Deformation has been mainly by epeirogenic movement and graben formation.

In the Perth Basin Phanerozoic, no case of compressive tectonics has been documented. Faulting is very common in the pre-Cretaceous sediments, and top basement is commonly displaced vertically 1,000 or 2,000 metres (3,280 or 6,560 ft). These faults are believed to be steep, although good evidence is lacking. However, there are clear indications that they are syn-sedimentary or growth faults. For instance, continuous thickening of successive stratigraphic intervals is a feature of all seismic interpretations. Moreover, the sedimentary environment in wells (Williams and Nicholls, 1966; Union Oil, 1968; Union Oil, 1969) is continuously that of a continental flood plain from the Lower Permian to the Lower Cretaceous. There is no evidence of marine invasions of the downthrown blocks such as would be caused by episodic movements and no good evidence of unconformities at which such marine intervals could be removed by erosion.

##### *Differential compaction as a cause of folding*

The Permian to Cretaceous sediments overlying basement are mainly sandstone. In Whicher Range No. 1 the lithological breakdown and percentages (over the logged interval below 56 metres (183 ft) BDF) are as follows:

Sandstone	....	3,765 metres (12,352 ft)	82%
Shale	....	688 metres (2,259 ft)	15%
Coal	....	144 metres (472 ft)	3%
Total	....	4,597 metres (15,083 ft)	100%

Estimates of the ultimate compactability of these lithologies range "from 30:1 to 12:1 in peats and coals, 9:1 to 4:1 in clayey muds and only 4:3 or 3:2 in sands" (Boswell, 1961, p. 85). Even if the lower compaction ratios are used it is clear that considerable differential compaction must have occurred between blocks. Top basement lies at a depth of from 4,500 metres (15,000 ft) to 10,000 metres (30,000 ft), where the resolution power of the seismic method is very limited. Only large faults have been detected, but within the major fault blocks it is likely that numerous intermediate order faults lie undetected. A structurally varied surface on top basement resulting from such faults and in turn causing differential compaction appears to be the most likely cause of structures mapped by seismic techniques at higher levels. The folds of Figure 17A thus appear to be drape structures. An attempt is made below to estimate the amount of compaction which has taken place at Whicher Range No. 1. Under "Topographic evidence" the effect of the possible continuation of differential compaction after the mid-Cretaceous emergence of the area is considered.

##### *Processes and rates of compaction*

Compaction results from several different physical and chemical processes which are controlled by the type of material, the subsurface conditions, and the passage of time. These processes are so complex and the variables so numerous that it is virtually impossible to quantify compaction precisely. By making approximations of the more important variables, however, it is attempted in the following section to arrive at an order of magnitude.

Sandstone compactability is so small relatively and takes place, mainly by mechanical rearrangement, so soon after deposition that it can be disregarded. For shale and coal somewhat lower compaction ratios than those quoted by Boswell (1961, p. 85) are used (i.e. 3:1 for clay to shale and 8:1 for plant debris to coal). These approximations should result in conservative compaction estimates providing that only a proportional amount of compaction is allowed for given conditions of overburden, temperature and geological time.

The great compactability of clays and plant debris is due primarily to their capacity to retain large volumes of water. Some clay minerals possess remarkably high water-retention capacities, for instance the montmorillonoids, but such minerals are not known to occur in appreciable proportions in the Perth Basin. It has been shown experimentally by Terzaghi (1925) that the porosity of a pure clay is reduced from about 70 per cent to about 37 per cent by a pressure of only about 18,300 grams per square centimetre (260 psi), which corresponds to an overburden of about 85 metres (280 ft). According to Hedberg (1936) this takes place principally by expulsion of free and adsorbed water, while contributory processes are the mechanical rearrangement of particles and elasticity in the presence of water. Porosity is further reduced to about 10 per cent primarily by the mechanical deformation of particles. It may be decreased to zero by loss of water through chemical combination (together with solution and recrystallization) under suitable conditions of pressure, temperature, and time.

It has been argued that in addition to pressure and temperature, the role of time is important in the process of compaction (McCoy and Keyte, 1934). An indication of this has come to light in recent years from the deep drilling of Cainozoic deltas (e.g. Dickinson, 1953). Abnormally high formation pressures encountered in the basal marine shales of the major regressive sequence in a Cainozoic delta show that despite great loading insufficient time has elapsed to allow dewatering (Hardin and others, 1963).

During the later slow compaction stage, the achievement of the ultimate potential compactibility is likely also to be subject to a delayed-action effect. Taking as an example the compaction of the Permian sequence in the present area, the maximum overburden was imposed by the mid-Cretaceous. It appears likely, however, that the processes of adsorbed water expulsion, loss of water through chemical combination, mechanical deformation of particles, solution and recrystallization did not proceed to the maximum potential stage for a considerable period of geological time and, in fact, may not even have done so by the present time.

To summarize, compaction of clays takes place very rapidly at first (in terms of geological time) and then quite slowly. The exact rate of compaction during the second stage is very difficult to determine but it is not very critical in terms of the present problem. Compaction probably continues long after loading has stopped owing to the low permeability of shales and the assumed slow

response of physical processes to imposition of overburden.

#### Amounts of Compaction

In attempting to quantify compaction between stated horizons at a given location over a certain period, it is necessary to make assumptions and approximations. Based on the theoretical considerations mentioned above and such scanty data as are available, the following assumptions are made regarding compaction at Whicher Range No. 1:

- (1) that the ultimate compactibilities of sand, clay and plant debris are zero, 3:1 and 8:1 respectively;
- (2) that under the local conditions of almost continuous sedimentation, the amount of compaction has been mainly a function of time and has continued from the cessation of deposition to the present; and
- (3) that compaction of clay and plant debris respectively to volumes of 25 per cent and 40 per cent greater than the ultimate compacted volumes took place within the first 30 million years and that straight line decreases in these volumes took place to 3 and 5 per cent respectively at an age of 270 million years.

The temperature gradient at Whicher Range No. 1 is moderate, about 19°C/1,000 metres (10.5°F/1,000 ft), and the role of temperature is not thought to be a critical control of compaction in this case.

TABLE 1. ESTIMATED COMPACTION AT WHICHER RANGE No. 1

System	Present thickness*				Compaction factor		Depositional thickness*			Compaction since mid-Cretaceous*		
	Sandstone	Shale	Coal	Total	Shale	Coal	Shale	Coal	Total	Shale	Coal	Total
Cretaceous	68	24	10	102	2.5:1	6.2:1	60	62	190	2	1	3
Middle and Upper Jurassic	908	154	0	1,060	2.6:1	6.5:1	400	0	1,306	13	0	13
Lower Jurassic	930	150	8	1,088	2.7:1	6.7:1	405	54	1,339	13	1	14
Triassic	1,490	178	2	1,670	2.8:1	7.0:1	498	11	1,999	16	0	16
Permian above T.D.	407	196	130	733	2.9:1	7.6:1	568	988	1,963	19	19	38
Permian below T.D. (Est.)	509	244	161	914	2.9:1	7.6:1	707	1,224	2,440	24	23	47
Total	4,810	946	311	5,567	....	....	2,638	2,339	9,287	87	44	131

\* All thicknesses are in metres—1 m = 3.281 ft

The figure obtained for total compaction (i.e. loss of thickness) at Whicher Range is about 3,700 metres (12,000 ft) (Table 1), of which about 130 metres (400 to 450 ft) is computed for the period since the mid-Cretaceous. Differential compaction can also be calculated across faults of known top basement throw, if one assumes that the lithological proportions are the same in the downthrown block. For instance, along the line of cross section XY (Figs. 17 and 18) Fault D has a basement throw of about 1,000 metres (3,300 ft) and differential compaction is therefore about 670 metres (2,200 ft). Similarly Fault M has a basement throw of about 2,000 metres (6,500 ft) and differential compaction is calculated to be about 1,350 metres (4,400 ft). These amounts of differential compaction occurred incrementally and were taken up until mid-Cretaceous by thicker sedimentation. Since mid-Cretaceous the amounts of differential compaction across Fault D and Fault M are computed as 30 metres (100 ft) and 43 metres (140 ft) respectively.

#### Topographic Evidence

The basic topographic data available are presented as a relief contour map in Plate 9. There are three main geomorphic elements (Fig. 19): the Swan Coastal Plain, the Darling Plateau and the "Low Plateau" (Finkl, 1971). Bounding these areas are the Darling Scarp and the Whicher Scarp while to the south a weak broken scarp (so far unnamed) separates the "Low Plateau" from the Scott Coastal Plain. The "Low Plateau" has also

been called the Blackwood Physiographic Area (Lowry, 1967), but the most appropriate name would appear to be Blackwood Plateau, which is used below in this paper.

Close examination of the topographic contours of the Blackwood Plateau (Plate 9) reveals a number of rectilinear ridges and valleys here referred to as positive and negative topographic lineaments respectively. The hypothesis is advanced that these may have originated by differential compaction over buried faults localizing the drainage lines over the downthrown blocks. The known basement faults (Fig. 17B) have been plotted on Plate 9 for comparison and although a number of possible lineaments, as plotted, appear to correspond approximately with seismic faults the objection may be raised that in these cases the correspondence is only an approximate one and that the downthrown side is not always the lower at the surface. The answer to this objection may be that over the Blackwood Plateau the seismic picture is very incomplete and approximate owing to the dissected topography and low superficial-weathering velocities.

The Blackwood Plateau consists of a lateritized surface with a local variation of relief of the order of 10 to 20 metres (30 to 70 ft). Regarding the northern Perth Basin and other areas it has been pointed out that lateritization is post-uplift (Playford, 1954), and this has been supported subsequently by Frider (1966). Field study has shown that this relationship holds good also in the area at present under consideration (Finkl, 1971). Dis-

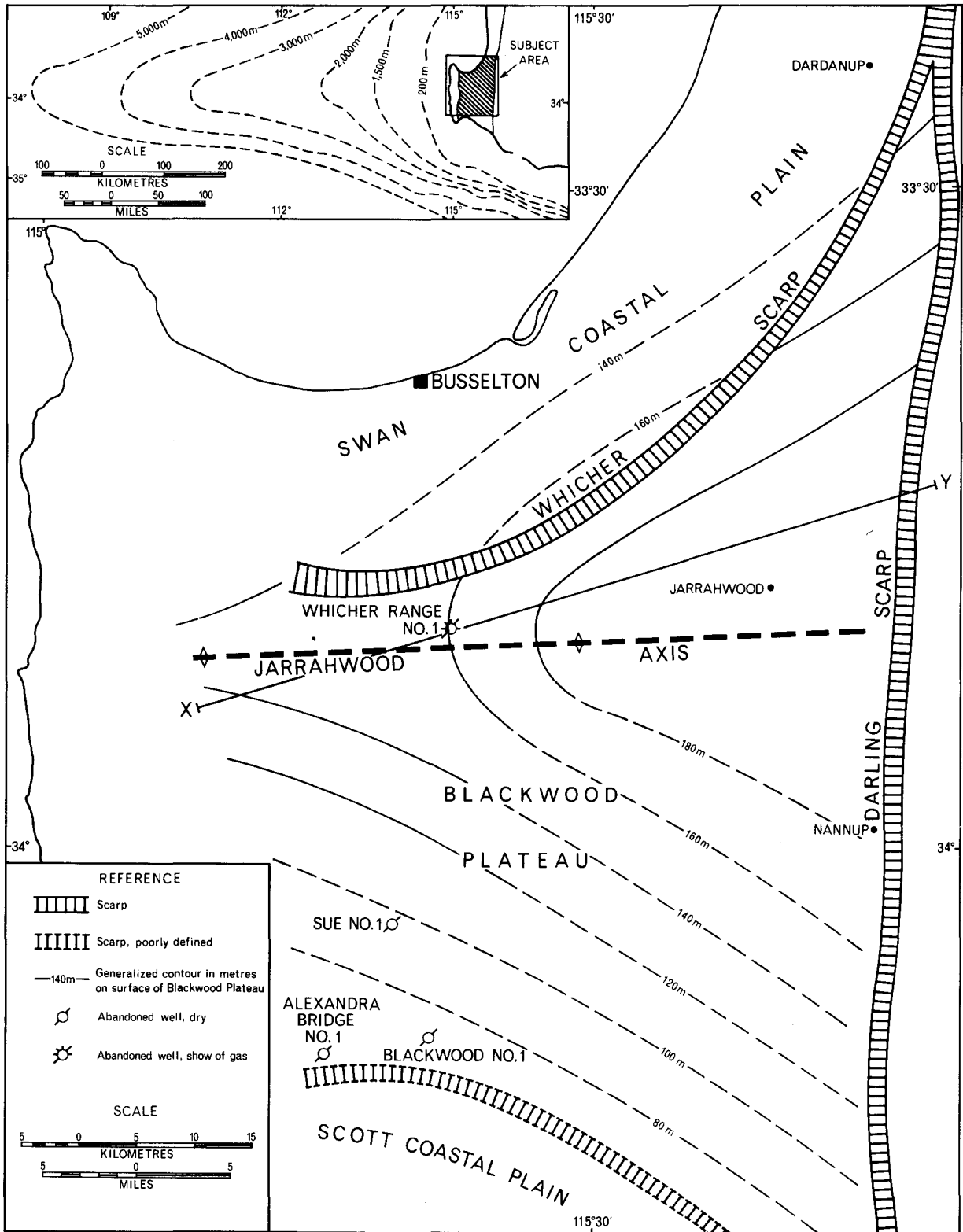


Figure. 19. Geomorphic features, Inset map shows the location of the area and bathymetric contours of the continental shelf and slope to the West (after Geological Society of Australia, 1960). 12890

section of the Blackwood Plateau has occurred simultaneously with continuing lateritization, however.

Examination of the air-photographs and of the 1:100,000 topographic sheets suggests that there is a systematic variation in the elevation of the semi-mature surface of the Blackwood Plateau. Generalized contours have been drawn on this surface (Fig. 19). The plane represented passes through the high points of the semi-mature surface (Fig. 18B). Between Whicher Range and the Darling Scarp the Blackwood Plateau has been deeply dissected by the Saint John Brook—Saint Paul Brook—Mill Brook tributary system of the Blackwood River.

The contours indicate an east-west axis of uplift with a gentle westward plunge. This axis is distinctly perpendicular to the main Perth Basin structural trend, and it is proposed to call it the Jarrahwood Axis after the small settlement of Jarrahwood about 23 kilometres (14 miles) north-west of Nannup.

The exact age of the uplift on the Jarrahwood Axis cannot readily be established within the present area of study. The axis does, however, correspond with and is thus probably a reactivation of, a long-established structural trend. To the west, the Leeuwin Block represents the culmination of a north-northwest — south-southeast — trending ridge, and a submarine ridge, 600 kilometres (370 miles) long of unknown origin, extends along the 34° S parallel between 1,500 metres (5,000 ft) and 5,000 metres (17,000 ft) (see Fig. 19, inset).

To the east, the southern boundary of the Yilgarn Block is approximately east-west (Daniels and Horwitz, 1969). Along the south coast, Lower Tertiary marine deposits lie up to 100 metres (330 ft) above present sea level (Cockbain, 1968), while near the edge of the continental shelf to the south a Tertiary column over 1,000 metres (several thousand feet) thick has been interpreted to extend westwards beyond the Darling Fault (Hawkins and others, 1965, Fig. 10). Lower Tertiary subsidence was followed by middle or later Tertiary uplift along an east-west axis lying to the north. This probably corresponds with the continuation of the Jarrahwood Axis which is therefore probably of middle or late Tertiary age.

The Whicher Scarp was formed by marine erosion of the uplifted Blackwood Plateau during the Pleistocene (Lowry, 1967, p. 3). It appears to owe its curving trend to resistance offered by elevation along the Jarrahwood Axis, together with the shielding effect of the Leeuwin Block to erosion from the west. A similar effect is seen to the south of the Jarrahwood Axis, although the scarp between the Blackwood Plateau and the Scott Coastal Plain is very dissected and poorly defined.

## CONCLUSIONS

1. *Basement growth faulting:* From the Lower Permian to the Upper Jurassic the subsidence of the southern Perth Basin took place by growth (or syn-sedimentary) faulting of Precambrian basement. Thicker sediments accumulated on the down-thrown blocks.

2. *Differential compaction:* Depositional thicknesses aggregated a column in the order of two-thirds thicker than the present one. Differential compaction between blocks was considerable. Within blocks the same process acting over smaller faults has given rise to gradually growing gentle folds eminently suitable for the entrapment of hydrocarbons.

3. *Lower Cretaceous compaction:* Continuing compaction in the Lower Cretaceous contributed to the subsidence which allowed deposition of the South Perth Formation. Further north, the Dandaragan Trough is deepest at both basal Cretaceous and top basement levels in roughly the same locality, near Dandaragan. Since the compaction estimates in this paper are conservative and the pre-Cretaceous Phanerozoic sediments of the Dandaragan Trough may contain a higher proportion of compactable sediments than at Whicher Range No.

1, it is conceivable that compaction was the sole cause of subsidence in the onshore Perth Basin during the Lower Cretaceous.

4. *Compaction faulting:* Differential compaction between fault blocks resulted in a greater throw on higher horizons than the displacement of the basement surface during a given period. The occasional faults encountered in the South Perth Formation may possibly have been caused by differential compaction localized over large basement faults, rather than by renewed movement on those faults.

5. *Topographic control:* Differential compaction appears to have influenced the present drainage pattern and is likely to have done so during times of emergence since the Lower Cretaceous. The distribution of the Bunbury Basalt may have been controlled in this way, and basement structure could also have influenced palaeocoastlines and hence accumulations of economic beach sand minerals.

6. *Tertiary uplift:* Post-Lower Cretaceous uplift has occurred extensively in the southern Perth Basin. Part of this is of Tertiary age and an axis of uplift of middle to late Tertiary age is recognizable from variations in the elevation of the Blackwood Plateau. The name Jarrahwood Axis is proposed for this. This axis appears to be the prime control for the position of the Whicher Scarp which was formed by marine erosion during the Pleistocene.

## REFERENCES

- Aasted, R. E., 1969, Perth Basin digital reflection seismic survey, Wonnerup—Flinders Project: Union Oil Development Corp. P.S.S.A. Rept. 68/3060 (unpublished).
- Boswell, P. G. H., 1961, Muddy sediments: Some geotechnical studies for geologists, engineers and soil chemists: Cambridge, Heffer, 140 p.
- Cockbain, A. E., 1968, The stratigraphy of the Plantagenet Group, Western Australia: West. Australia Geol. Survey Ann. Rept. 1967, p. 64-67.
- Daniels, J. L., and Horwitz, R. C., 1969, Precambrian tectonic units of Western Australia: West. Australia Geol. Survey Ann. Rept. 1968, p. 37-38.
- Dickinson, G., 1953, Geological aspects of abnormal reservoir pressures in Gulf Coast Louisiana: Am. Assoc. Petroleum Geologists Bull., v. 37, p. 410-432.
- Finkl, C. W., Jr., 1971, Levels and laterites in southwestern Australia: Search, v. 2, 10, p. 382-383.
- Geological Society of Australia, Tectonic Map Committee, 1960, Tectonic map of Australia: Australia Bur. Mineral Resources, first edn.
- Hardin, J., Hager, R. V., Jr., Friedman, M., and Feather, J. N., 1963, Experimental deformation of sedimentary rocks under confining pressure tests: pore pressure tests: Am. Assoc. Petroleum Geologists Bull. v. 47, p. 717-755.
- Hawkins, L. V., Hennion, J. F., Nafe, J. E., and Thyer, R. F., 1965, Geophysical investigations in the area of the Perth Basin, Western Australia: Geophysics, v. 30, no. 6, p. 1026-1052.
- Hedberg, H. D., 1936, Gravitational compaction of clays and shales: Am. Jour. Sci., v. 31, 5, p. 241-287.
- Lowry, D. C., 1967, Busselton and Augusta, W.A.: Australia Bur. Mineral Resources 1:250,000 Geol. Series Explan. Notes (Sheets SI/50-5 and SI/50-9).
- McCoy, A. W., and Keyte, W. R., 1934, Present interpretations of the structural theory for oil and gas migration and accumulation: Problems of Petroleum Geology (Sydney Powers Memorial Volume), Am. Assoc. Petroleum Geologists, p. 279-282.

- Playford, P. E., 1954, Observations on laterite in Western Australia: Australian Jour. Sci. v. 17, 1, p. 11-14.
- Prider, R. T., 1966, The lateritized surface of Western Australia: Australian Jour. Sci. v. 28, 12, p. 443-451.
- Quilty, J. H., 1963, Perth Basin aeromagnetic survey, W.A.: Australia Bur. Mineral Resources Rec. 1963/74 (unpublished).
- Royal Australian Survey Corps, 1970, 1:100,000 topographic survey, Sheets 1930 (Busselton), 2030 (Donnybrook) and 2031 (Bunbury).
- Sealy, B. E., 1969, Harvey (239) Seismic Project, Perth Basin, final report: West Australian Petroleum Pty. Ltd. P.S.S.A. Rept. 69/3022 (unpublished).
- Terzaghi, C., 1925, Principles of soil mechanics: Engineering News Record, 95.
- Thyer, R. F., and Everingham, I. B., 1956, Gravity survey of the Perth Basin, Western Australia: Australia Bur. Mineral Resources Bull. 33.
- Union Oil Development Corp., 1968, Whicher Range No. 1 well completion report: Union Oil Development Corp. P.S.S.A. Rept. (unpublished).
- Union Oil Development Corp., 1969, Blackwood No. 1 well completion report: Union Oil Development Corp. P.S.S.A. Rept. (unpublished).
- Williams, C. T., and Nicholls, J., 1966, Sue No. 1 well completion report: West Australian Petroleum Pty. Ltd. P.S.S.A. Rept. (unpublished).

## PRELIMINARY RESULTS OF GEOLOGICAL MAPPING IN THE OFFICER BASIN, WESTERN AUSTRALIA, 1971

by D. C. Lowry\*, M. J. Jackson†, W. J. E. van de Graaff‡, and P. J. Kennewell‡

### ABSTRACT

This report describes the results of the joint mapping project conducted in the Officer Basin during 1971 by the Geological Survey of Western Australia and the Bureau of Mineral Resources. The Officer Basin, which extends from South Australia into Western Australia, contains a poorly known sedimentary sequence of Proterozoic and Phanerozoic age. The following basin boundaries have been provisionally adopted for the Western Australian part of the basin:

- (1) the Warri Gravity Ridge in the north;
- (2) the base of the Townsend Quartzite in the northeast;
- (3) the northern limit of the Tertiary deposits of the Eucla Basin in the south;
- (4) the extent of the Permian glacial deposits in the west and southwest.

The following new stratigraphic names are herein defined: Lefroy Beds, Lupton Beds, Clutterbuck Beds (Proterozoic), Babbagoola Beds, Browne Beds (Proterozoic or Palaeozoic), Wanna Beds (Palaeozoic), Samuel Formation (Cretaceous), Lampe Beds (Cretaceous to Cainozoic) and Plumridge Beds (Cainozoic). The Townsend Quartzite is redefined to exclude the Lefroy Beds (old name: Brown Range Siltstone). Babbagoola Beds and Browne Beds are amended names with respect to previous unpublished usage, and Bejah Claystone is an amendment of "Bejah Beds". The name Paterson Formation is used in preference to "Wilkinson Range Beds" or "Yowalga Sandstone", which names were previously used for the Permian glacial and fluvio-glacial deposits in the Officer Basin.

Permian and Cretaceous deposits have been traced from the Canning Basin southwards into the Officer Basin. Permian fluvio-glacial and lacustrine deposits were mapped over most of the basin. Fossiliferous marine Cretaceous strata are confined to the northern part of the Officer Basin (north of latitude 27°45'S), while unfossiliferous siliciclastics and tholeiitic basalt of probable Lower Palaeozoic age crop out near the South Australian border.

### INTRODUCTION

The Western Australian part of the Officer Basin, which has an area of about 260,000 square kilometres (100,000 miles<sup>2</sup>), underlies much of the area known as the Gibson and Great Victoria Deserts (Plate 10). The Gibson Desert was mapped by Wells (1963), but only a few geological traverses

were made over the remainder prior to 1970, (Talbot and Clarke, 1917; Forman, 1933; Utting, 1955; Leslie, 1961; Sofoullis, 1962; and Daniels, 1969a, b, c).

The Hunt Oil-Placid Oil-Exoil consortium made aeromagnetic, photogeological, gravity and seismic surveys over parts of the basin, culminating in stratigraphic drilling during 1965 and 1966 (P. Jackson, 1966b). However, little attention was paid to the surface exposures and little information was collected on the relative distribution of the marine Cretaceous rocks in the north (Wells, 1963), the fluvial and glacial Permian deposits in the south (Talbot and Clarke, 1917), and the Lower Palaeozoic sequence now known near the South Australian border.

The Alliance Petroleum-Union Oil consortium, which worked on the northern part of the basin, made an aeromagnetic and a photogeological survey in addition to their surface reconnaissances. Their reconnaissance surveys gave some useful information on the regional distribution of the various formations (Wilson, 1964; Mack and Herrmann, 1965).

A geological reconnaissance by the Geological Survey of Western Australia and the Bureau of Mineral Resources in 1970 resulted in a preliminary reappraisal of the geology of the basin (M. Jackson, 1971; Lowry, 1971). This reconnaissance was followed by a systematic mapping programme in 1971. Because of difficult ground transport, mapping was mainly done by helicopter. The results of this survey, which will be followed by stratigraphic drilling and geophysical work in 1972, are to be recorded on 18 geological maps on a 1:250,000 scale and in a bulletin synthesizing the geology of the basin. The aims of this paper are to systematize the stratigraphic nomenclature and to make available rapidly the principal findings of the 1971 mapping programme. Rock unit names which do not conform to the Australian Code of Stratigraphic Nomenclature (Geol. Soc. Aust., 1964) have been used in previous literature on the basin. To avoid confusion and to systematize the stratigraphy of the basin all the names used have been examined and modified where necessary to bring them into accord with the code. In addition two units which do not form part of the Officer Basin sequence, i.e. the Clutterbuck Beds (a Precambrian inlier forming part of the Amadeus Basin Proterozoic succession) and the Plumridge Beds (Eucla Basin), are also described.

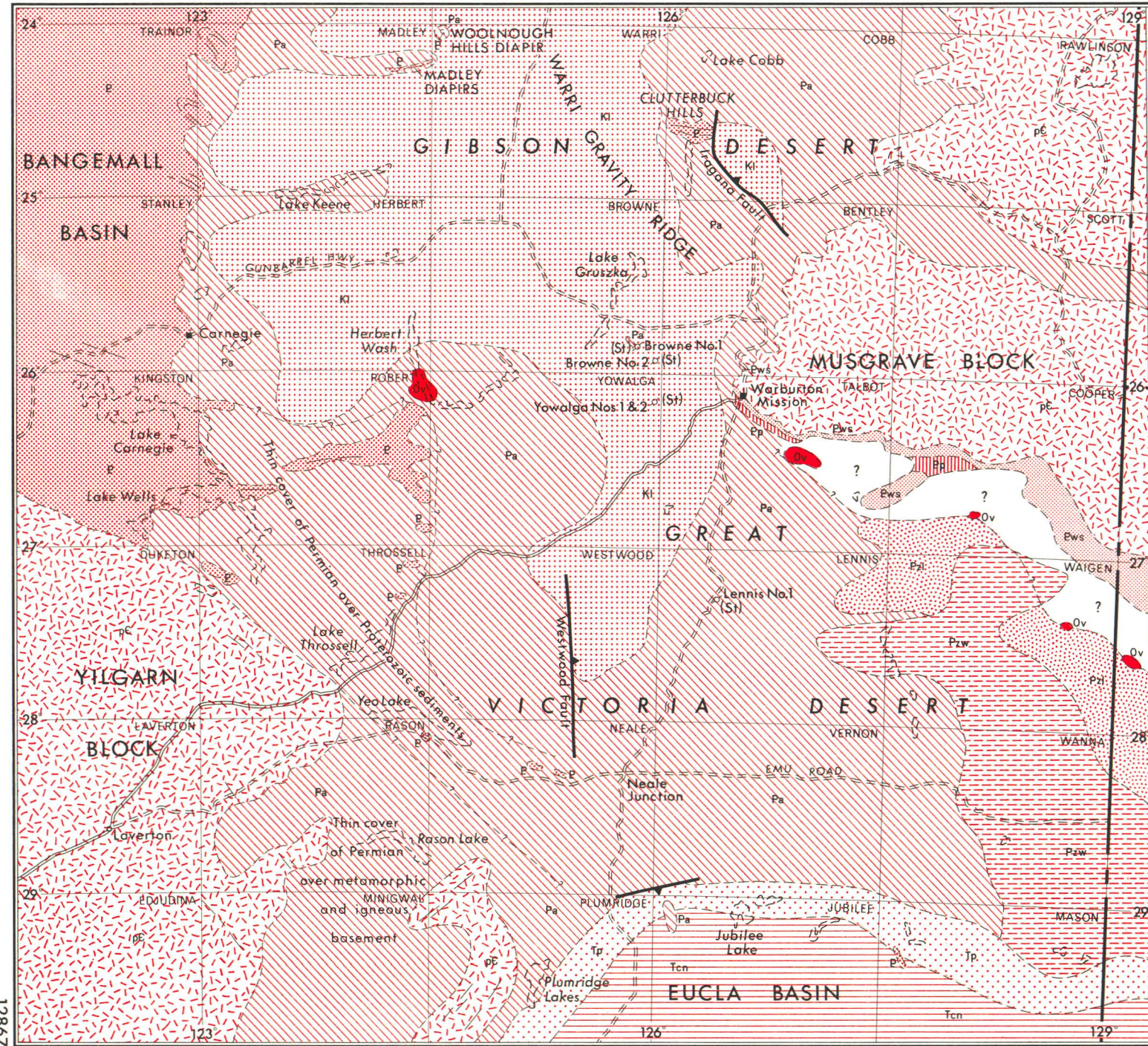
\* Geological Survey of Western Australia—presently with West Australian Petroleum Pty. Ltd.

† Geological Survey of Western Australia

‡ Bureau of Mineral Resources Geology and Geophysics

An expanded version of this paper will be available as a Bureau of Mineral Resources 1972 Record

**PRELIMINARY SOLID GEOLOGY  
MAP OF THE OFFICER BASIN**

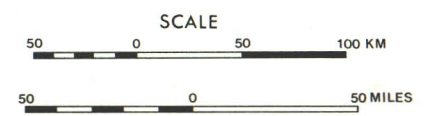


REFERENCE

- |                           |                  |     |  |
|---------------------------|------------------|-----|--|
| CAINOZOIC                 | MIOCENE          | Tp  | Plumridge Beds                                   |
|                           |                  | Tcn | Colville Sandstone and Nullarbor Limestone       |
| MESOZOIC                  | LOWER CRETACEOUS | Kl  | Bejah Claystone and Samuel Formation             |
|                           |                  | Pa  | Paterson Formation                               |
| PALAEOZOIC                | PERMIAN          | Pzw | Wanna Beds                                       |
|                           |                  | Psl | Lennis Sandstone                                 |
|                           |                  | Ov  | Table Hill and Kulyong Volcanics                 |
| PROTEROZOIC               | ORDOVICIAN       | P   | Undivided  |
|                           |                  | Pl  | Lupton Beds and Lefroy Beds                      |
|                           |                  | Ews | Townsend Quartzite                               |
| PROTEROZOIC AND ARCHAEOAN |                  | ?   | Geology uncertain                                |
|                           |                  | pE  | Metamorphic, igneous and minor sedimentary rocks |

SYMBOLS

- Geological boundary, position approximate
- Inferred subsurface continuation of boundary
- Fault
- Trend lines
- (St)σ Drillhole (stratigraphic)
- Graded road
- Track
- State boundary





## BASIN DEFINITION

The name Officer Basin has been used in Western Australia for the area between the Bangemall Basin, the Yilgarn Block, the Eucla Basin, the Musgrave Block and the Canning Basin. This basin contains a Proterozoic and Phanerozoic sequence and is the extension of the Officer Basin in South Australia, where the name Officer Basin originated (Australia B.M.R., 1960, p. 39). Geophysical evidence indicates that a sedimentary sequence up to 5,500 metres (18,000 ft) thick is present in parts of the area (P. Jackson, 1966b; Turpie, 1967). Owing to the flat-lying attitude of the surface strata, exposures give little information on the nature of this thick sedimentary sequence.

Ideally, a sedimentary basin, i.e. an area characterized by long-continued subsidence and more or less concomitant sedimentation, should be defined in genetically meaningful terms. That is, the boundaries chosen should preferably be of structural and/or palaeogeographic significance. In the present state of knowledge it is unfortunately impossible to give more than a provisional definition of the Officer Basin.

The limits of the Officer Basin (W.A.) used here are the Warri Gravity Ridge in the north, the extent of the continuously preserved Permian in the west and southwest, the Tertiary cover of the Eucla Basin in the south, and the base of the Townsend Quartzite in the northeast. The first three of these limits were used by Playford and Cope (1970, Fig. 3) and the fourth limit is in accordance with South Australian usage (Johnson, 1963; Parkin, 1969). Two of these boundaries, the extent of the Permian deposits and the extent of the Tertiary cover of the Eucla Basin, are merely convenient limits. The Warri Gravity Ridge probably corresponds with a basement high, and is a convenient boundary with the Canning Basin. The base of the Townsend Quartzite is chosen as a boundary as it is the first major, well exposed, angular unconformity of regional significance beneath the Phanerozoic strata that crop out over much of the basin. Although in the overlying sequence some low-angle unconformities do occur, none of these seem to be of the same magnitude and extent as the one at the base of the Townsend Quartzite, which marks the beginning of a widespread depositional phase.

Two of these other unconformities are fairly important. These are the unconformity beneath the Kulyong, Table Hill, and Officer Volcanics, and that beneath the Paterson Formation. Neither of these unconformities is adopted as the boundary of the Officer Basin in the eastern part of the surveyed area, because it would not conform to South Australian usage, where the Officer Basin was first named and described.

The subsurface extent of the Townsend Quartzite and the overlying Proterozoic units is unknown. Also unknown is the relationship of the Proterozoic sequence in the Musgrave Block to the gently folded, southeasterly striking, evaporite-bearing siliciclastic and carbonate sequences on the western edge of the basin (Trainor (SG/51-2), Stanley (SG/51-6), Kingston (SG/51-10), 1:250,000 Sheets). Mack and Herrmann (1965) estimated the sequence on the western side of the basin, which belongs to the Bangemall Group, to be 9,000 metres (30,000 ft) thick. These Bangemall Group sediments of probable Middle Proterozoic age, possibly form the bulk of the succession indicated by aeromagnetic data in the deeper parts of the Officer Basin.

## STRATIGRAPHY

### TOWNSEND QUARTZITE

The name Townsend Quartzite was used by Sofoulis (1962) for a unit of sandstone and quartzite exposed in the Brown and Townsend Ranges (Talbot (SG/52-9) 1:250,000 Sheet). Daniels (1969b) evidently considers a section near Lillian Gorge as the type section. Farbridge (*in* Daniels, 1969b) describes this section as consisting of a lower unit, 85 metres (280 ft) thick, of thin to

thick-bedded, flaggy, feldspathic, micaceous sandstone with sparse pebble and shale-flake beds, which is overlain by a unit of coarse to very coarse-grained, thick to very thick-bedded sandstone, 170 metres (560 ft) thick, with large-scale cross-bedding and containing some cobble and pebble beds.

Daniels' mapping shows the Townsend Quartzite to be conformable on the Mission Group near Warburton, but further east it overlies progressively older units of the Musgrave Block, with an angular unconformity. On the Birksgate (SG/52-15) 1:250,000 Sheet (S.A.) the lateral equivalent of the Townsend Quartzite, the Pindyin Sandstone, unconformably overlies granites and gneisses of the core of the Musgrave Block (Major, 1968). The base of the Townsend Quartzite is therefore an angular unconformity of regional significance. The Lefroy Beds conformably overlie the Townsend Quartzite.

A littoral to sub-littoral environment of deposition is interpreted for the well sorted, evenly bedded sandstones, whereas the coarse-grained pebbly parts are probably fluvial.

The Townsend Quartzite is considered to be of Middle to Upper Proterozoic age as it unconformably overlies the Tollu Group, which was dated as  $1,060 \pm 140$  million years old (Daniels 1969b), and as its lateral equivalent, the Pindyin Sandstone, underlies a sequence that contains rare Ediacara-type (latest Proterozoic) fossils (Major, 1968).

### LEFROY BEDS

Lefroy Beds is the name proposed herein for a sequence of well bedded siltstone to very fine-grained sandstone, which has been referred to informally as "Brown Range Siltstone" (P. Jackson, 1966; Daniels, 1969b). Daniels (1969b) included this unit, which is about 200 metres (700 ft) thick at Ainslie Gorge, in the Townsend Quartzite. The type section of the Lefroy Beds is located near Ainslie Gorge (26°14'S, 126°38'E, grid reference 469742, Talbot (SG/52-9) 1:250,000 Sheet), and its name is taken from Point Lefroy, 11 kilometres (7 miles) east-southeast of the type section.

Though Daniels (1969b) considered the upper boundary to be a disconformity we interpret both the upper and lower contacts as conformable, as they are located in gradational sequences. A very quiet, shallow-marine environment of deposition is interpreted for the Lefroy Beds, and their age is Middle to Upper Proterozoic.

### LUPTON BEDS

The name Lupton Beds is proposed herein for a sequence of conglomerate and sandstone which Daniels (1969b) informally called the "Upper Proterozoic Glacial Deposits". The type section is located at Lupton Hills, 26°31'S, 128°01'E, on the Cooper (SG/52-10) 1:250,000 Sheet. The name Lupton Hills has been submitted to the Geographic Nomenclature Committee, and has been formally approved. At the type locality a lower unit, approximately 175 metres (580 ft) thick, of unbedded, very poorly sorted, pebble to boulder conglomerate, and an upper unit, about 65 metres (210 ft) thick, of medium to fine-grained, well sorted, medium to thick-bedded quartz arenite with interbeds of siltstone and conglomerate, can be distinguished. Near the type section of the Lefroy Beds dropstones are common in the Lupton Beds.

Pebbles and boulders (maximum size 80 centimetres or 2 ft 8 in) in the conglomerates can be matched with various lithologies of the Blackstone Range area, indicating important erosion. Nevertheless the only exposed contact with the underlying Lefroy Beds is considered to be conformable, as it is located in a gradational sequence. The Lupton Beds are unconformably to disconformably overlain by the Kulyong, Table Hill, or Officer Volcanics, or by younger units.

The poorly sorted conglomerates are interpreted as tillites, and the sandier part of the sequence, with dropstones, as fluvio-glacial deposits. Being a glacial deposit of pre-Permian age, the Lupton Beds are considered to be of Upper Proterozoic age.

#### CLUTTERBUCK BEDS

Clutterbuck Beds is the name proposed herein for a 4,260-metre (14,000 ft) thick sandstone sequence exposed in the Clutterbuck Hills (24°35'S, 126°15'E, Cobb (SG/52-1) 1:250,000 Sheet). Leslie (1961), Wells (1963), Wilson (1964), and Brown and others (1968) referred to this range as the "Tragana Hills", but the name Clutterbuck Hills has priority.

The Clutterbuck Beds in the type section (from grid reference 428944 to 427938 and 422938 to 422934) consist of red-brown, purple-brown, fine to coarse-grained, well sorted, medium to thick-bedded, feldspathic arenites, with thin interbeds of laminated siltstone or very fine-grained sandstone. Low-angle cross-stratification in sets less than 1 metre (3 ft) thick, and beds with clay-clast impressions are common in the lower part of the sequence. Scattered, well rounded quartz and quartzite pebbles, pebble beds, and festoon cross-stratification in sets several metres thick are common in the upper 1,000 metres (3,300 ft).

The Clutterbuck Beds are exposed in a steeply dipping, partly fault-bounded inlier, which is completely surrounded by Permian and younger deposits. Little is known about their stratigraphic relationships because of the isolated position of the inlier, the absence of fossils, the lack of distinction of the lithologies and the concealment of the upper and lower boundaries of the unit. Wells (1963) noted lithological similarities between this unit and the Upper Proterozoic Carnegie Formation, Maurice Formation, and Ellis Sandstone of the Amadeus Basin. On the basis of these similarities an Upper Proterozoic age is inferred for the Clutterbuck Beds. A shallow marine to intertidal environment of deposition is inferred for these sediments.

As the Clutterbuck Hills outcrops occur to the northeast of the Warri Gravity Ridge, the Clutterbuck Beds probably do not occur in the Officer Basin.

#### BABBAGOOLA BEDS

The name Babbagoola Beds is herein proposed for a unit first described in an unpublished report by P. Jackson (1966a) as "Babbagoola Formation" which name was published by Peers and Trendall (1968). Jackson used the name "Babbagoola Formation" for an evaporite-bearing sequence, which was intersected in Hunt Oil-Placid Oil Yowalga No. 2 well (26°10'S, 125°58'E, Yowalga (SG/51-12) 1:250,000 Sheet). As this unit is only known from this one drillhole, the name Babbagoola Beds is preferred. The name is derived from the Babbagoola Rock Hole (26°26'S, 126°11'E, Talbot (SG/52-9) 1:250,000 Sheet). The interval from 846 to 989 metres (2,775 to 3,246 ft) in Yowalga No. 2 is the type section. P. Jackson (1966b) described three separate units within the Babbagoola Beds. Unit "A", from 846 to 887 metres (2,775 to 2,910 ft) consists of interbedded sandstone and shale with anhydrite and gypsum as fracture and vein fillings. Unit "B", from 887 to 893 metres (2,910 to 2,930 ft) consists of fine-grained dolomite, with anhydrite and gypsum as fracture and vein fillings. Unit "C", from 893 to 989 metres (2,930 to 3,246 ft) consists of interbedded shale and siltstone.

An angular unconformity separates the Babbagoola Beds from the overlying Officer Volcanics in the structure in which Yowalga No. 2 was drilled. The base of the unit is unknown.

Glover (*in* P. Jackson, 1966a) suggests an oxidizing, evaporitic environment of deposition for the Babbagoola Beds. Balme (*in* P. Jackson, 1966a) infers an Upper Proterozoic to Lower Cambrian age, as primitive microfossils (leiospheres), known from the Sinian of the U.S.S.R., occur in this unit. Balme based his opinion also on the absence of typically Lower Palaeozoic cuticular microfossils. He then adds: "The data are consistent with a Proterozoic age, insofar as one can place reliance on the biostratigraphic value of such poorly diversified assemblages of indistinctive microfossils". The Babbagoola Beds are lithologically similar to the

Proterozoic evaporite-bearing deposits described by Mack and Herrmann (1965) from the western edge of the basin, and to the ?Ordovician carbonate-shale sequences of the Southern Canning Basin. However, without reliable datings no correlations can be established.

#### BROWNE BEDS

The name Browne Beds is herein proposed for a unit first described in an unpublished report by P. Jackson (1966b) as the "Browne Evaporites". This name was published by Peers and Trendall (1968). The unit consists of interbedded dolomitic limestone, calcareous shale, anhydrite, gypsum and salt, and as it is only poorly known from Hunt Oil-Placid Oil wells Browne Nos. 1 and 2, the name Browne Beds is preferred. The interval from 133 to 387 metres (435 to 1,269 ft) in Browne No. 1 (25°51'S, 125°48'E, Browne (SG/51-8) 1:250,000 Sheet) is considered to be the type section and the name is derived from that of the map sheet.

Both Browne Nos. 1 and 2 were drilled in a structure of diapiric origin and therefore little can be said about the stratigraphic position of the Browne Beds, except that they are unconformably overlain by the Paterson Formation.

An evaporitic environment of deposition is inferred for this unit and its age is probably Proterozoic (*cf.* Babbagoola Beds).

Considering their relative position and the lithological similarities it is possible that the Babbagoola Beds and the Browne Beds will be shown to form a single stratigraphic unit.

#### KULYONG, TABLE HILL AND OFFICER VOLCANICS

Major and Teluk (1967) described exposures of tholeiitic basalt on the Kulyong (SG/52-16-620) 1:63,360 Sheet, S.A., and named these Kulyong Volcanics. These outcrops in South Australia form the eastern extremity of a discontinuous band of basalt outcrops extending into Western Australia. At 26°49'S, 128°05'E, grid reference 628670, Cooper (SG/52-10) 1:250,000 Sheet, this basalt is overlain with a sharp contact by the Lennis Sandstone.

Basalts that are petrographically very similar are exposed at Table Hill. These were first described by Talbot and Clarke (1917) who referred to these outcrops as "volcanic rocks of Table Hill", and regarded them as part of their Townsend Range Series. Daniels (1969b) and Peers (1969) use the name Table Hill Volcanics. We examined a section at Table Hill (26°28'S, 126°53'E, grid reference 497713, Talbot (SG/52-9) 1:250,000 Sheet) and measured approximately 26 metres (85 ft) of finely crystalline, greyish-green to dark grey basalt, with approximately 2 metres (6 to 7 ft) of poorly exposed very fine-grained to medium-grained micaceous sandstone in the middle of the sequence. The basalt is unconformably overlain by 4 to 5 metres (13 to 16 ft) of highly ferruginous conglomeratic sandstone of the Paterson Formation.

P. Jackson, in an unpublished report (1966a) first used the name Officer Volcanics for a basalt sequence encountered in the Hunt Oil-Placid Oil Yowalga No. 2 and Hunt Petroleum-Exoil Lennis No. 1 wells. Peers and Trendall (1968) first published the name. The choice of the name "Officer" was unfortunate as the nearest geographic feature of that name is the Officer River (Woodroffe (SG/52-12) 1:250,000 Sheet, S.A.), about 600 kilometres (370 miles) east of the drillholes. The Officer Volcanics most probably correlate with a seismic high-velocity layer which has been recognized over a large part of the Officer Basin, and P. Jackson (1966b) concluded that the volcanics are present throughout most of the deeper portion of the basin.

Yowalga No. 2 intersected 118 metres (385 ft) of Officer Volcanics between 728 and 846 metres (2,390 to 2,775 ft) which interval is considered to be the type section.

The Officer Volcanics overlie the Babbagoola Beds with an angular unconformity in Yowalga No. 2, and in both Lennis No. 1 and Yowalga No. 2 the volcanics are overlain with an erosional contact by the Lennis Sandstone.

Peers (1969) described the petrology of these three units of volcanic rocks and concluded that all three occurrences are petrologically very similar, describing them as massive to vesicular tholeiitic basalts. The great lateral continuity of the Officer Volcanics, the fact that both the Kulyong and the Officer Volcanics are overlain by Lennis Sandstone, and their petrological similarity, strongly suggest that they are in fact a single unit. The Table Hill Volcanics most likely also form part of this extensive basalt layer, but due to poor exposure their stratigraphical relationships have not been determined.

Radiometric dating of the Officer Volcanics gave ages of 1,000 and 1,143 million years and of 331, 357, 445, 446, and 447 million years (P. Jackson, 1966a). Samples of the Kulyong Volcanics have been dated as 475 and 485 million years old (Major and Teluk, 1967). The Table Hill Volcanics have not been dated. Jackson (1966b) interpreted the Officer Volcanic datings as indicating a Proterozoic age, and considered the younger ages as being due to metamorphism. Peers (1969), however, argued that the Proterozoic dates are based on the assumption of an unlikely initial  $Sr^{87}/Sr^{86}$  value, and concluded that the 445 million years date is the more reliable. This age fits quite well with the datings of the Kulyong Volcanics and Peers (1969) therefore considers the Kulyong, Table Hill and Officer Volcanics to be of Ordovician age. This is corroborated by the fact that at least at Table Hill and on the Kulyong Sheet these volcanic rocks overlie the Proterozoic Townsend Quartzite, Lefroy Beds and Lupton Beds (Daniels, 1969b). Considering the fact that these units unconformably overlie the Tollu Group, which has been dated at  $1,060 \pm 140$  million years (Daniels, 1969b), it is very unlikely that the 1,000 and 1,143-million-year datings of the Officer Volcanics are correct.

Though there is thus strong evidence that the Kulyong, Table Hill and Officer Volcanics are in fact one stratigraphic unit, we prefer to await the results of additional radiometric dating on samples from several localities before proposing to discard two of the three names.

A poorly exposed outcrop of undated, but petrologically similar basalt, at the Herbert Wash ( $26^{\circ}10' S$ ,  $124^{\circ}28' E$ , Robert (SG/51-11) 1:250,000 Sheet) is also regarded as part of this volcanic sequence.

As very few other possibilities for dating the fill of the Officer Basin are available, a reliable dating of the volcanic rocks is of the greatest importance for an understanding of the whole basin.

#### LENNIS SANDSTONE

The name Lennis Sandstone was first used in an unpublished report by P. Jackson (1966a) and published by Peers and Trendall (1968) without description. The name was apparently derived from Lennis Hills,  $27^{\circ}13' S$ ,  $126^{\circ}50' E$ , Lennis (SG/52-13) 1:250,000 Sheet, which lie 47 kilometres (29 miles) east-northeast of Hunt Petroleum-Exoil Lennis No. 1 well, where the unit was first recognized.

The Lennis Sandstone consists of red to reddish-brown, fine to medium-grained, subangular to sub-rounded, moderate to well sorted, feldspathic micaceous sandstone. Red, micaceous siltstone beds up to 3 metres (10 ft) thick, are interbedded with the sandstone at several localities. Bedding ranges from laminated to very thick parallel-bedded, but medium to thick bedding is dominant. The medium to thick beds are often internally laminated or cross-laminated. Cross-stratification is mostly of the trough type, and occurs in sets 20 centimetres to 1 metre (8 in to 3 ft 4 in) thick. Tabular, red siltstone clasts up to a few centimetres in diameter are common.

Hunt Oil-Placid Oil well Yowalga No. 2 which intersected 321 metres (1,055 ft) of Lennis Sandstone between 407 and 728 metres (1,335 and 2,390 ft) is designated as the type section, and exposures at grid reference 552623 on the Lennis Sheet as the reference section.

The Lennis Sandstone unconformably overlies the Officer Volcanics in Lennis No. 1 and Yowalga No. 2. On the Cooper (SG/52-10) 1:250,000 Sheet it overlies the Kulyong Volcanics with a sharp, possibly disconformable contact. In both Yowalga No. 2 and Lennis No. 1 the Lennis Sandstone is unconformably overlain by the Paterson Formation. On the Wanna (SH/52-2), Waigen (SG/52-14), Cooper (SG/52-10) and Lennis (SG/52-13) 1:250,000 Sheets the Lennis Sandstone is conformably to disconformably overlain by the Wanna Beds.

Major (1968) described similar sandstones occurring on the Birksgate (SG/52-15) 1:250,000 Sheet, S.A., and Continental Oil Company Birksgate No. 1 well ( $27^{\circ}56'20'' S$ ,  $129^{\circ}48'10'' E$ , Henderson and Tauer, 1967) also intersected probable Lennis Sandstone between 159 and 501 metres (522 and 1,650 ft).

The main characteristic of the formation, its red colour, seems to be primary, as it is present both in the subsurface and in outcrop. Though red colours are most common in terrestrial deposits, the Lennis Sandstone is interpreted as a shallow marine deposit.

As it lies between the Ordovician volcanics and the Permian Paterson Formation, the age of the Lennis Sandstone is within the range of Ordovician to Upper Carboniferous, but an Ordovician, Silurian or Devonian age seems most likely. Possible lateral equivalents of the Lennis Sandstone and the overlying Wanna Beds are the ?Silurian Tandalgoo Red Beds of the Canning Basin, and the ?Silurian-Devonian Mereenie Sandstone of the Amadeus Basin.

#### WANNA BEDS

Wanna Beds is the name proposed herein for a unit of white to pale green, fine to very fine-grained, well sorted, slightly micaceous sandstone. Bedding ranges from thinly laminated to very thickly bedded. Cross-stratification in sets of up to 6 metres (20 ft) in thickness is ubiquitous. White claystone clasts commonly occur along the scoured bases of the cross-sets and along the fore-sets.

The type section is located at  $28^{\circ}49' S$ ,  $128^{\circ}16' E$ , grid reference 642427, Wanna (SH/52-2) 1:250,000 Sheet, and the name is taken from the nearby Wanna Lakes. The thickness of the Wanna Beds is estimated to be in the order of tens of metres.

On the basis of their regional distribution the Wanna Beds are inferred to disconformably overlie the Lennis Sandstone on the Cooper (SG/52-10) and northern part of the Waigen (SG/52-14) 1:250,000 Sheets (Plate 10). At grid reference 649596 on the Waigen Sheet a gradational contact between the two units is exposed, which suggests a conformable relationship in the southeastern part of the surveyed area.

Outcrops of Wanna Beds along the Serpentine Lakes (Noorina (SH/52-3) 1:250,000 Sheet) in South Australia, have been described by Forbes (1969) and Krieg (1971). They regarded these deposits as probable Observatory Hill Beds of ?Cambrian age. As these sandstones do not have a very striking resemblance to the type section of the Observatory Hill Beds as described by Wopfner (1969), and as they definitely overlie the Kulyong Volcanics and the Lennis Sandstone (thus ruling out a Cambrian age) the introduction of the new name seems appropriate.

The presence of the large-scale cross-bedding, among other characteristics, indicates a shallow marine environment with strong tidal currents for the Wanna Beds (van de Graaff, 1972). Because of the evidence for the existence of strong tidal currents the absence of coarse-grained siliciclastics (except claystone intraclasts) indicates a lack of supply of such material. Because of this it is unlikely that the Wanna Beds are laterally equivalent to the Paterson Formation, as this formation contains a high proportion of coarse-grained siliciclastics, and the smallest distance between outcrops of the two units is only 21 kilometres (13 miles). The Wanna Beds are most likely disconformably to

unconformably overlain by the Paterson Formation. Their age is probably in the range of Ordovician to Upper Carboniferous. Possible lateral equivalents of the Wanna Beds are the ?Silurian-Devonian Mereenie Sandstone of the Amadeus Basin, and the ?Silurian-Devonian Mintabie Sandstone of the eastern Officer Basin as described by Krieg (1969).

#### PATERSON FORMATION

Paterson Formation is the name used for a unit of highly variable lithology, which consists mainly of very poorly sorted conglomerate, pebbly sandstone, sandstone, and claystone with or without dropstones. Previously the names "Wilkinson Range Series", or "Wilkinson Range Beds" (Talbot and Clarke, 1916, 1917) and "Yowalga Sandstone" (P. Jackson, 1966b) were also used for this unit in the Officer Basin. However, the unit is continuous with, and is lithologically identical to, the Paterson Formation in the Canning Basin as described by Talbot (1920) and Traves and others (1956). As the Paterson Formation is better described, and as it has already been mapped by Wells (1963) in the northern part of the basin, the name Paterson Formation is preferred to "Wilkinson Range Beds", although strictly speaking the latter name has priority. The name "Yowalga Sandstone" has never been formalized through publication and does not, therefore, have priority.

Thickness of the formation is very variable as it overlies an irregular surface on the western side of the basin. At Woolnough Hills (24°05'S, 124°34'E, Warri (SG/51-4) 1:250,000 Sheet) a thickness of over 335 metres (1,100 ft) is exposed, and the Hunt Oil-Placid Oil Yowalga Nos. 1 and 2 wells intersected 367 metres (1,199 ft) and 312 metres (1,025 ft) respectively of the unit. Detailed descriptions of the Paterson Formation in the Officer Basin are given by Wells (1963), P. Jackson (1966b), M. Jackson (1971), and Lowry (1971).

The Paterson Formation unconformably to disconformably overlies all older units, and is in turn disconformably overlain by the Samuel Formation or the Bejah Claystone. In the southern part of the surveyed area the Tertiary sequence of the Eucla Basin unconformably overlies the Paterson Formation.

The quantitatively most important lithologies are interpreted as glacial tillites, and fluvio-glacial outwash, quiet lacustrine, lacustrine delta, and lacustrine beach deposits. Marine deposits have not been recognized but could be present. A lower Permian (Sakmarian) age for the Paterson Formation has been established by palynological dating (Wells, 1963; Balme *in* P. Jackson, 1966a).

In the northern part of the basin, Wells (1963) recognized undifferentiated Mesozoic sediments and Wilson (1964) distinguished Jurassic deposits. At Woolnough Hills, Wilson (1964) mapped extensive Jurassic deposits. These deposits, however, contain poorly sorted conglomerates which are interpreted as tillites. A Permian age is therefore interpreted for these coarse-grained deposits which are considered to form part of the Paterson Formation. Fine-grained "Jurassic" deposits in this area are also tentatively considered as Paterson Formation. A complete lack of datings of these sediments, however, precludes any definite correlations.

#### SAMUEL FORMATION

Samuel Formation is the name proposed herein for a unit of laminated to thin-bedded, fine to medium-grained sandstone, siltstone, and claystone. The sandstones are moderately to well sorted, and indistinctly cross-bedded in part, whereas the grains are moderately to well rounded. Bioturbation is common in these sediments, which weather purple, red, green and brown.

The Samuel Formation partly corresponds to the "undifferentiated Cretaceous" of Wells (1963, p. 24), the "undifferentiated Lower Cretaceous" of P. Jackson (1966b, p. 44), and the Jurassic and Cretaceous of Wilson (1964).

Outcrops at Mount Charles, Gunbarrel Highway (25°45'S, 126°11'E, Bentley (SG/52-5) 1:250,000 Sheet) are designated as the type section, and the name is taken from Mount Samuel, 25 kilometres (16 miles) to the west (25°46'S, 125°56'E). A thickness of 15 metres (48 ft) is exposed at the type section.

The base of the formation is exposed at Browne diapir (25°51'S, 125°48'E) where it disconformably overlies the Paterson Formation. Its contact with the overlying Bejah Claystone is gradational. Seismic and drillhole information suggest a combined thickness for the Samuel Formation and Bejah Claystone of up to 300 metres (920 ft) along much of Gunbarrel Highway.

Sedimentary structures and fossils indicate a quiet, shallow marine environment of deposition. The molluscan fauna permits dating as Aptian (Skwarko, 1967).

#### BEJAH CLAYSTONE

The name Bejah Claystone is here proposed as an amendment to the name "Bejah Beds" (Veevers and Wells, 1961, p. 166), as the distribution, age and stratigraphic relationships of this unit are now better known. The Bejah Claystone consists of indistinctly bedded, often bioturbated, white claystone with minor intercalations of very fine-grained sandstone. The claystone has a conchoidal fracture, especially if silicified (porcelanite). Radiolaria are fairly common in these white claystones.

Veevers and Wells (1961) evidently considered Bejah Hill (Runton (SF/51-15) 1:250,000 Sheet) in the Canning Basin as the type locality, and an unnamed locality at 25°28'S, 125°06'E, grid reference 302833 (Browne (SG/51-8) 1:250,000 Sheet) is here designated as the main reference section for the Officer Basin.

In the surveyed area the greatest measured thickness of the Bejah Claystone is about 30 metres (100 ft). The Bejah Claystone conformably overlies the Samuel Formation, but on the western side of the basin the formation rests disconformably on the Paterson Formation. Its upper limit is always erosional and a disconformable to unconformable contact separates the unit from the Lampe Beds.

The molluscan fauna indicates an Aptian (Lower Cretaceous) age (Skwarko, 1967). A very quiet, shallow-marine environment of deposition with slow sedimentation is inferred from the fine grain size, the common bioturbation, and the fossils.

#### LAMPE BEDS

The name Lampe Beds is proposed herein for a thin (maximum observed thickness of 3 metres (10 ft)) sequence of poorly sorted, medium to very coarse-grained sandstone, which locally grades into quartz-pebble conglomerate. Bedding is indistinct and ranges from medium to thick. These deposits are everywhere intensely silicified and are commonly referred to as sileretes. Such deposits have been observed over nearly all older formations. If occurring on the Paterson Formation or one of the Proterozoic units which contain coarse-grained siliciclastics, such silicified deposits can have originated by *in situ* soil formation without any mechanical transport of the constituent materials. If, however, such a coarse-grained deposit overlies the Bejah Claystone, Samuel Formation, Wanna Beds, Lennis Sandstone or a Proterozoic unit which does not contain any coarse-grained siliciclastics, erosion in neighbouring areas, transport and deposition of the sediment must have occurred before silicification during pedogenesis. Therefore we only use the name Lampe Beds if such a deposit overlies one of the above mentioned fine-grained units, as we are defining rock-stratigraphic rather than soil-stratigraphic units.

The Lampe Beds are named after Mount Lampe, which is located about 16 kilometres (10 miles) north-northwest of the type section at Mount Johnson (25°24'S, 124°25'E, Herbert (SG/51-7) 1:250,000 Sheet). It is a widespread unit in the same area where the Samuel Formation and Bejah Claystone occur, i.e. the northern part of the basin.

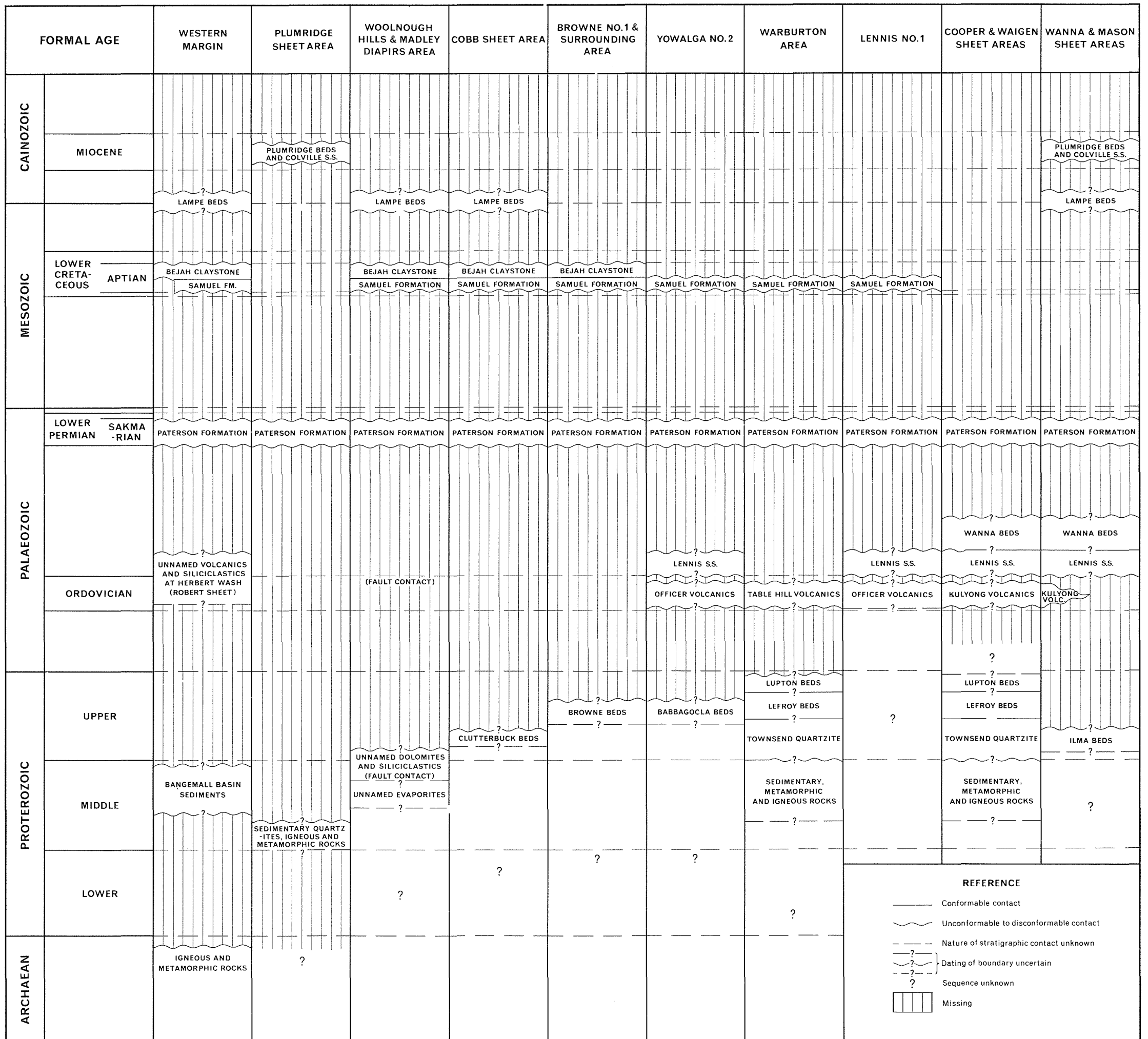


Figure 20. Correlation diagram of stratigraphic units in the Officer Basin Area.

The Lampe Beds unconformably to disconformably overlie any older units, and as they occur as thin cappings on mesas and rises, their upper limit is always erosional.

Although intense silicification has obscured the original textures and structures, the poor sorting, moderate rounding of the quartz pebbles, indistinct bedding, and the sometimes scoured lower contact all suggest a fluvial environment of deposition.

As parts of the Lampe Beds are intensely ferruginized to lateritized at most localities, the Lampe Beds are distinctly older than the laterite. The laterite in the Officer Basin is considered to have formed before or during the Miocene. This contention is based on the following observations:

- (1) The Lower Miocene Colville Sandstone in the Eucla Basin is not lateritized.
- (2) A more or less well developed laterite is present in the Officer Basin, on the Permian and Cretaceous sediments.
- (3) The lateritized surface, where not obscured by sand dunes or destroyed by erosion, displays an integrated drainage system which is now inactive.
- (4) This drainage system seems to have discharged to the south, that is, into the Eucla Basin. This is supported by the fact that the Plumridge Beds, which form part of the Eucla Basin, contain silcrete and ferruginized silcrete pebbles that can only have come from the north.
- (5) The lateritized surface with its old drainage system is recognizable up to the limits of the Eucla Basin, but neither on the Plumridge Beds nor on the Colville Sandstone outcrop band is there any indication that an integrated drainage system ever existed.

These observations indicate that after deposition and emergence of the Plumridge Beds and the Colville Sandstone (which is reliably dated as Lower Miocene), little surface discharge occurred, or at least insufficient surface discharge to form an integrated drainage system. This implies that the more humid conditions necessary for the formation of laterite in the Officer Basin only existed before or during the Miocene.

Therefore an Upper Cretaceous to Lower Tertiary age is inferred for the unfossiliferous Lampe Beds, as they overlie the Aptian Bejah Claystone and are older than the laterite.

#### PLUMRIDGE BEDS

Plumridge Beds is the name proposed herein for a sequence of poorly exposed, fine-grained sandstone, siltstone and claystone, with some intercalations of poorly sorted conglomeratic sandstone, which occurs in the northern part of the Eucla Basin. The conglomeratic sandstones are characterized by the presence of pebbles of ferruginized silcrete, and fragments of fresh feldspar.

Outcrops at 29°43'S, 125°04'E, on the Plumridge (SH/51-8) 1:250,000 Sheet, are designated as the type section, and the name is taken from Plumridge Lakes, which lie approximately 25 kilometres (16 miles) northeast of the type section. The maximum exposed thickness is about 10 metres (33 ft), and the unit is estimated to be a few tens of metres thick. The distribution of the Plumridge Beds suggests that they disconformably to unconformably overlie the Wanna Beds or the Paterson Formation. A kankar soil overlies the Plumridge Beds.

A fluvial to paralic environment of deposition is interpreted for the Plumridge Beds, and their occurrence as a band along the northern boundary of the Eucla Basin suggests that they are lateral equivalents to the Colville Sandstone. This would imply a Lower Miocene age for the Plumridge Beds.

#### REFERENCES

- Australia Bureau of Mineral Resources, 1960, Summary of oil-search activities in Australia and New Guinea to June, 1959: Australia Bur. Mineral Resources Rept. 41a.
- Brown, D. A., Campbell, K. S. W., and Crook, K. A. W., 1968, The geological evolution of Australia and New Zealand: Pergamon Press.
- Daniels, J. L., 1969a, Explanatory notes on the Bentley 1:250,000 Geological Sheet, W.A.: West. Australia Geol. Survey Rec. 1969/13 (unpublished).
- 1969b, Explanatory notes on the Talbot 1:250,000 Geological Sheet, W.A.: West. Australia Geol. Survey Rec. 1969/14 (unpublished).
- 1969c, Explanatory notes on the Cooper 1:250,000 Geological Sheet, W.A.: West. Australia Geol. Survey Rec. 1969/16 (unpublished).
- Forbes, B. G., 1969, Helicopter geological survey in the Officer and Eucla Basins: South Australia Dept. of Mines, Prelim. Rept. Bk. 68/107.
- Forman, F. G., 1933, Conclusions of report on a reconnaissance survey of the country lying between Laverton and the Warburton Ranges: West. Australia Dept. of Mines Ann. Rept. 1932, p. 41-43.
- Geological Society of Australia, 1964, Australian code of Stratigraphic Nomenclature: The Griffin Press, Adelaide (fourth edn.).
- Graaff, W. J. E., van de, 1972, The Wanna Beds—an analogue of Recent North Sea sediments: West. Australia Geol. Survey Ann. Rept., 1971, p. 56.
- Henderson, S. W., and Tauer, R. W., 1967, Birksgate No. 1 well completion report: Continental Oil Co. (unpublished).
- Jackson, M. J., 1971, Notes on a geological reconnaissance of the Officer Basin, W.A., 1970: Australia Bur. Mineral Resources Rec. 1971/5 (unpublished).
- Jackson, P. R., 1966a, Hunt Oil-Placid Oil, well completion report No. 2, Yowalga: Hunt Oil Co. Rept. (unpublished).
- 1966b, Geology and review of exploration, Officer Basin, Western Australia: Hunt Oil Co. Rept. (unpublished).
- Johnson, J. E., 1963, Basal sediments of the north side of the Officer Basin: South Australia Geol. Survey Quart. Geol. Notes 7.
- Krieg, G., 1969, Geological developments in the Eastern Officer Basin of South Australia: Australian Petrol. Expl. Assoc. Jour. 1969, v.g. (II), p. 8-13.
- 1971, Comments on Noorina, Wyola, Maurice 1:250,000 Geological Sheets: South Australia Dept. of Mines Rept. Bk. 71/4.
- Leslie, R.B., 1961, Geology of the Gibson Desert, Western Australia: Frome Broken Hill Pty. Ltd., Rept. 3000-G-38 (unpublished).
- Lowry, D. C., 1971, Geological reconnaissance of the Officer Basin, 1970: West. Australia Geol. Survey Rec. 1971/6 (unpublished).
- Mack, J. E., and Herrmann, F. A., 1965, Reconnaissance geological survey of the Alliance Gibson Desert block PE 205H, 206H, 207H, Western Australia: Union Oil Development Corp., G.R. no. 18 (unpublished).
- Major, R. B., 1968, Preliminary notes on the geology of the Birksgate 1:250,000 Sheet area: South Australia Geol. Survey Rept. 66/122 (unpublished).
- Major, R. B., and Teluk, J. A., 1967, the Kulyong Volcanics: South Australia Geol. Survey Geol. Notes 22, p. 8-11.
- Parkin, L. W., (ed), 1969, Handbook of South Australian Geology: South Australia Geol. Survey, Adelaide.

- Peers, R., 1969, A comparison of some volcanic rocks of uncertain age in the Warburton Range area: West. Australia Geol. Survey Ann. Rept. 1968, p. 57-61.
- Peers, R., and Trendall, A. F. 1968, Precambrian rocks encountered during drilling in the main Phanerozoic sedimentary basins of Western Australia: West. Australia Geol. Survey Ann. Rept. 1967, p. 69-77.
- Playford, P. E., and Cope, R. N., 1970, Petroleum exploration in Western Australia in 1969: West. Australia Geol. Survey Ann. Rept. 1969, p. 14-19.
- Skwarko, S. K., 1967, Mesozoic mollusca from Australia and New Guinea: Australia Bur. Mineral Resources Bull. 75.
- Sofoulis, J., 1962, Geological reconnaissance of the Warburton Range Area, Western Australia: West. Australia Geol. Survey Ann. Rept. 1961, p. 65-69.
- Talbot, H. W. B., 1920, The geology and mineral resources of the North-West, Central and Eastern Divisions between longitudes 119° and 122°E and latitudes 22° and 28°S: West. Australia Geol. Survey Bull. 83.
- Talbot, H. W. B., and Clarke, E. de C., 1916, The geological results of an expedition to the South Australian Border, and some comparisons between Central and Western Australia suggested thereby: Royal Soc. West Australia Jour. Proc. III, v. 3, p. 70-98.
- 1917, A geological reconnaissance of the country between Laverton and the South Australian border: West. Australia Geol. Survey Bull. 75.
- Traves, D. M., Casey, J. N., and Wells, A. T., 1956, The geology of the south-western Canning Basin, Western Australia: Australia Bur. Mineral Resources Rept. 29.
- Turpie, A., 1967, Giles-Carnegie seismic survey, Western Australia, 1961-1962: Australia Bur. Mineral Resources Rec. 1967/123 (unpublished).
- Utting, E. P., 1955, Geological investigations,—Permits to explore 39H, 40H, and 41H: Rept. for Australian Oil Exploration Ltd. (unpublished).
- Veevers, J. J., and Wells, A. T., 1961, The geology of the Canning Basin, Western Australia: Australia Bur. Mineral Resources Bull. 60.
- Wells, A. T., 1963, Reconnaissance geology by helicopter in the Gibson Desert, W. A.: Australia Bur. Mineral Resources Rec. 1963/59 (unpublished).
- Wilson, R. B., 1964, The geology of permits to explore Nos. 205H, 206H and 207H, Western Australia: Rept. for Alliance Petroleum Australia N.L. (unpublished).
- Wopfner, H., 1969, Lithology and distribution of the Observatory Hill Beds, Eastern Officer Basin: Royal Soc. South Australia Trans. 93, p. 169-187.

## THE WANNA BEDS—AN ANALOGUE OF RECENT NORTH SEA SEDIMENTS

by W. J. E. van de Graaff

### ABSTRACT

The Wanna Beds occur in the eastern part of the Western Australian section of the Officer Basin. Their lithological characteristics are uniform over a large area, and, together with the textural and compositional maturity of the sediments and the types of cross-bedding, this indicates a shallow-subtidal marine environment of deposition. They are considered to be an analogue of Recent sand deposits of the North Sea.

### INTRODUCTION

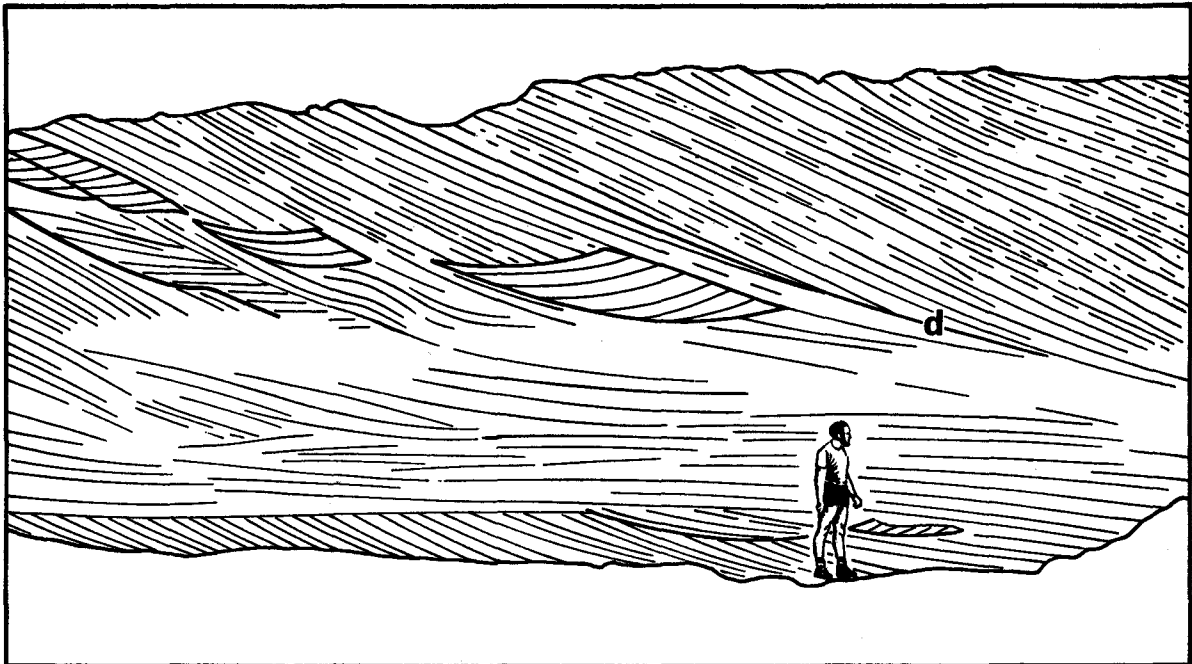
The name Wanna Beds has been formally proposed by Lowry and others (1972), for a sandstone unit exposed over a wide area in the Officer Basin. It underlies parts of the Lennis, Waigen, Wanna and Mason 1:250,000 Sheet areas and is known to extend into South Australia. Its known extent is shown in Lowry and others (1972, Plate 10). The formation is of uniform lithology over a large area (approximately 32,000 square kilometres, 12,375 miles<sup>2</sup>) and the absence of any datings or of any marker beds precludes correlations within the formation. Nevertheless, the presence of well preserved sedimentary structures and of only slightly modified textures permits a reconstruction of the depositional environment.

### FIELD CHARACTERISTICS

The Wanna Beds consist predominantly of white-weathering (pallid zone of laterite profile), well to very well sorted, fine to very fine-grained, quartz arenite. Stratification ranges from thinly laminated to very thick bedded. The laminated to thin, or occasionally medium-bedded parts are characterized by very regular, continuous, and mostly very distinct bedding planes. The medium to very thick beds are mostly cross-bedded. These large-scale cross-beds are predominantly of the scoop type (Allen, 1963). Preserved set thickness generally ranges from 0.05 metres to about 1.50 metres (2 in to 5 ft). The width of the scoops is

up to at least 10 metres (33 ft). In the down-current direction individual cross-sets have been traced for over 60 metres (200 ft). The cross-sets are laminated to very thin bedded. The laminae of the cross-sets are normally concave upwards, and have an asymptotic relationship to the basal contact, and horizontally bedded strata can often be traced into low-angle cross-stratification. Although scoop cross-stratification of Allen's (1963) pi type is most common, cross-bedding of types nu and xi also occur quite frequently. Cross-stratification similar to the planar types of cross-bedding described by McKee (1966) was observed at one locality.

In one outcrop, on the southern side of a small salt lake (lat. 28° 21', long. 127° 45') on the Wanna Sheet area, a large-scale beta cross-set is exposed. The preserved height of this set is 5.3 metres (17 ft). This cross-set can be traced in the original down-current direction for over 50 metres (165 ft), but its preserved extent could be much greater. On the northern side of the salt lake, cross-stratification of similar dimensions and orientation is exposed, which indicates that both exposures are in a single cross-set which has a lateral extent of at least 150 metres (490 ft). Superimposed on, and alternating with the steeply dipping (up to 25°) fore-sets are some large-scale cross-sets of beta-type cross-stratification, which indicate a direction of transport diametrically opposite to that of the bigger set (Fig. 21). The smaller cross-sets are up to 81 centimetres (2 ft 8 in) thick. They are present only in the upper two-thirds of the preserved larger cross-set over a distance of 12 metres (40 ft). On the northern side of the salt lake small-scale cross-beds, opposing the largest set, occur at the toes of these larger fore-sets. The opposing cross-sets are locally erosive on the larger one, and are in turn covered with an erosive contact, by the larger cross-set. Interfingering of the laminae of the two opposing cross-sets has not been observed. Several discontinuity planes were observed in the larger cross-set. Such discontinuity planes were also seen in other outcrops.



12892

Figure 21. Large-scale beta cross-stratification with superimposed smaller cross-sets. Note discontinuity plane (marked d) between fore-sets of the large-scale cross-set. Traced from photograph.

In a number of outcrops, claystone clasts up to 10 centimetres (4 in) long are concentrated at the erosion bases of cross-sets or along the fore-set bedding planes. These claystone clasts are identical in composition to the extensive thin claystone beds which are present in some outcrops.

Indistinct burrows are present in a few exposures.

#### INTERPRETATION OF DEPOSITIONAL ENVIRONMENT

An eolian or a high-energy aquatic environment is indicated by uniform lithology over a large area, good sorting, textural and compositional maturity, and the large-scale cross-bedding. The predominance of scoop-type cross-bedding and the rareness of tabular-planar to wedge-planar cross-stratification (McKee, 1966), combined with the common presence of shale clasts favours an aquatic environment.

The 5-metre (16 ft) high cross-set described above permits a more detailed interpretation to be made. Its most important characteristic is the presence of the superimposed cross-sets, which indicates a direction of transport diametrically opposite to that of the main set. Such a configuration can be interpreted as either a mega-ripple (sand-wave, underwater dune) deposit with backflow ripples, or as having been formed by two independent currents. Backflow ripples which are formed by a leeside backflow vortex in the trough behind a mega-ripple, typically are most common at the base of the fore-sets and gradually disappear on the higher part of the main fore-sets. The backflow-ripple fore-sets and those of the main ripple interfinger; evidence of the continuous interaction of two currents (Boersma and others, 1968). The superimposed cross-sets under discussion do not interfinger with the main set and are restricted to the upper part of the preserved main cross-set. Therefore these superimposed cross-sets are not backflow-vortex phenomena, but are due to an independent current system. This is corroborated by the argument that such large-scale backflow ripples would require a primary current of enormous strength. Only the small-scale cross-set observed at the very base of the large fore-sets could conceivably be due to a backflow current, but the prime criterion of interfingering laminae was not visible.

Opposing transport directions of two alternating but independent current systems are good evidence of an environment swept by tidal currents (De Raaf and Boersma, 1971).

The tidal environment is here considered to comprise all those depositional environments where clastic sedimentation processes are determined by tides.

De Raaf and Boersma (1971) divide the tidal environment into four sub-environments: (1) inshore, (2) offshore, (3) intertidal, (4) subtidal. Estuaries and barrier-protected lagoons are considered to be inshore tidal environments. The North Sea is an example of an offshore tidal environment. The intertidal environment is defined as the zone between water levels at ebb and flood. The subtidal environment is ambiguously named but is here taken to comprise those environments below the water level at ebb, where clastic sedimentation processes are determined by tides.

Of the features considered by De Raaf and Boersma (1971) to be characteristic of tidal deposits, the following have been recognized in the Wanna Beds: (a) variable to opposing current directions in successive beds, (b) single cross-sets containing discontinuity planes, (c) general absence of regular sequences, for example fining upwards or coarsening upwards sequences; (a) and (b) are evidence of bi-directional intermittent currents, which are typical of the tidal environment.

Of the four tidal sub-environments the intertidal zone is best known because of greater accessibility. The subtidal environment is less well known and studies of recent subtidal environments rarely deal with the sedimentary structures and sequences expected in ancient deposits of this type.

By process of elimination we can make a reliable interpretation of the Wanna Beds. The uniform lithology over the whole outcrop precludes interpretation as an estuarine deposit. The general absence of clay and mudstone rules out a low-energy intertidal-flat environment, which is characterized by muddy sediments and fining upwards sequences formed by migrating channels (Van Straaten, 1951; Reineck, 1963). Klein (1970) describes a high-energy intertidal deposit, which is very similar to the Wanna Beds. From his



illustrations, however, it is obvious that deposits formed by migrating and stationary channels are common in this environment. Such channel deposits have not been observed in the Wanna Beds. Also their uniform appearance over a large area does not indicate a near-shore environment. This leaves the offshore subtidal environment.

Recent offshore subtidal environments and their sediments are described by, among others, Off (1963), Stride (1963), Houbolt (1968) and Terwindt (1970). The southern part of the North Sea, which seems to be a fairly typical example of a tide-swept shallow sea, is the best known. The sea floor is largely covered by tidal-current ridges and mega-ripples. The mega-ripples are mostly straight, asymmetric ripples, but strongly curved forms also occur. These sandwaves occur in waters less than 50 metres (165 ft) deep, and their crests rise up to about 15 metres (45 ft) above the adjoining troughs. Hoyt (1967) reports similar mega-ripples which are over 5 metres (16 ft) high. The crests of these mega-ripples are about 6 to 8 metres (20 to 26 ft) below mean low water. Houbolt (1968) shows that the tidal-current ridges can have very steep cross-bedding (up to 30°), and the presence of steep fore-sets therefore does not indicate a mega-ripple origin for a deposit. The current velocities reported by Houbolt (1968) are about 0.5 to 1.0 metres per second (1 to 2 knots) under normal conditions. Much higher current velocities can be expected to occur during storms and spring tides.

The Wanna Beds are interpreted as having been formed in such a shallow subtidal environment, with migrating lunate ripples giving rise to the ubiquitous scoop-type cross-bedding, and the large 5-metre (16 ft) high cross-set type being either a tidal-current ridge or a mega-ripple.

#### REFERENCES

- Allen, J. R. L., 1963, The classification of cross-stratified units, with notes on their origin: *Sedimentology*, v. 2, p. 93-114.
- Boersma, J. R., Meene, E. A. van de, and Tjalsma, R. C., 1968, Intricated cross-stratification due to interaction of a mega-ripple with its leeside system of backflow ripples (Upper-pointbar deposits, Lower Rhine): *Sedimentology*, v. 11, p. 147-162.
- De Raaf, J. F. M., and Boersma, J. R., 1971, Tidal deposits and their sedimentary structures: *Geologie en Mijnbouw*, v. 50, p. 479-504.
- Houbolt, J. J. H. C., 1968, Recent sediments in the southern bight of the North Sea: *Geologie en Mijnbouw*, v. 47, p. 245-273.
- Hoyt, J. H., 1967, Occurrence of high-angle stratification in littoral and shallow neritic environments, Central Georgia Coast, U.S.A.: *Sedimentology*, v. 8, p. 229-238.
- Klein, G. de Vries, 1970, Depositional and dispersal dynamics of intertidal sand bars: *Jour. Sed. Petrology*, v. 40, p. 1095-1127.
- Lowry, D. C., Jackson, M. J., Graaff, W. J. E. van de, and Kennewell, P. J., 1972, Preliminary results of geological mapping in the Officer Basin, Western Australia, 1971: *West. Australia Geol. Survey Ann. Rept.* 1971, p. 50.
- McKee, E. D., 1966, Structures of dunes at White Sands National Monument, New Mexico (and a comparison with structures of dunes from other selected areas): *Sedimentology*, v. 7, p. 1-69.
- Off, T., 1963, Rhythmic linear sand bodies caused by tidal currents: *Am. Assoc. Petroleum Geologists Bull.*, v. 47, p. 324-341.
- Reineck, H. E., 1963, Sedimentgefüge in Bereich der südlichen Nordsee: *Abh. Senck. Naturforsch. Ges.*, v. 505, p. 1-138.
- Straaten, L. M. J. U. van, 1951, Texture and genesis of Dutch Wadden Sea sediments: 3rd Int. Congr. Sedimentology, Groningen-Wageningen, *Proc. The Netherlands*, p. 225-249.
- Stride, A. H., 1963, Current-swept sea floors near the southern half of Great Britain: *Geol. Soc. London Quart. Jour.*, v. 119, p. 175-199.
- Terwindt, J. H. J., 1970, Sand waves in the southern bight of the North Sea: *Marine Geology*, v. 10, p. 51-67.

## A RECENT FAULT SCARP IN THE LORT RIVER AREA, RAVENSTHORPE 1:250,000 SHEET

by R. Thom

#### ABSTRACT

A curvilinear feature clearly discernible on air-photographs of the Ravensthorpe 1:250,000 Sheet resembles the traces of the faults associated with the Meckering and Calingiri earthquakes of 1968 and 1970 respectively. Ground investigation has shown that this feature is a low scarp and it is suggested that there has been an earthquake in the area in fairly recent times.

#### INTRODUCTION

Examination of the 1-mile photo-mosaics of the northeast of the Ravensthorpe 1:250,000 Sheet reveals a curvilinear feature about 40 kilometres (25 miles) long trending approximately north-northeast and slightly concave to the east. The resemblance to the traces of the faults associated with the Meckering earthquake of 1968 (Lewis, 1969; Gordon, in prep.) and the Calingiri earthquake of 1970 (Gordon, in prep.) is illustrated in Figure 22. All three faults have a similar trend, with a sigmoid curve in a similar dextral sense. The relative simplicity of the Lort River Fault in the diagram is partly due to representation on this scale. In detail the air-photographs reveal a more complex fracture (Plate 11A).

#### SURFACE EXPRESSION OF LORT RIVER FAULT

The feature is a low scarp for much of its length. Commonly the scarp is about 2 metres (6 ft) high and is most readily observed where the land has been cleared. In areas of scrub the scarp tends to be indistinct or even invisible. To the south where the fault bifurcates, the most easterly scarp is the higher (Plate 12A). In all cases where the scarp has been observed, there is relative uplift to the east.

#### GEOLOGY OF THE AREA

The geology is shown in Plate 13. The area is underlain by Proterozoic gneiss, the trend of which is dominantly north-northeast, with dips vertical or steep east. Generally exposure is poor. Trends may be visible on air-photographs where there is no surface outcrop but where superficial cover is thin.

Cainozoic units include "sandplain" horizons (here grouped as Cz), a reworked sandplain unit Qq, which can contain kankar, and an erosion surface Qr. It is in these units that the fault scarp occurs. No solid outcrop was detected on the ground on the line of the fault.



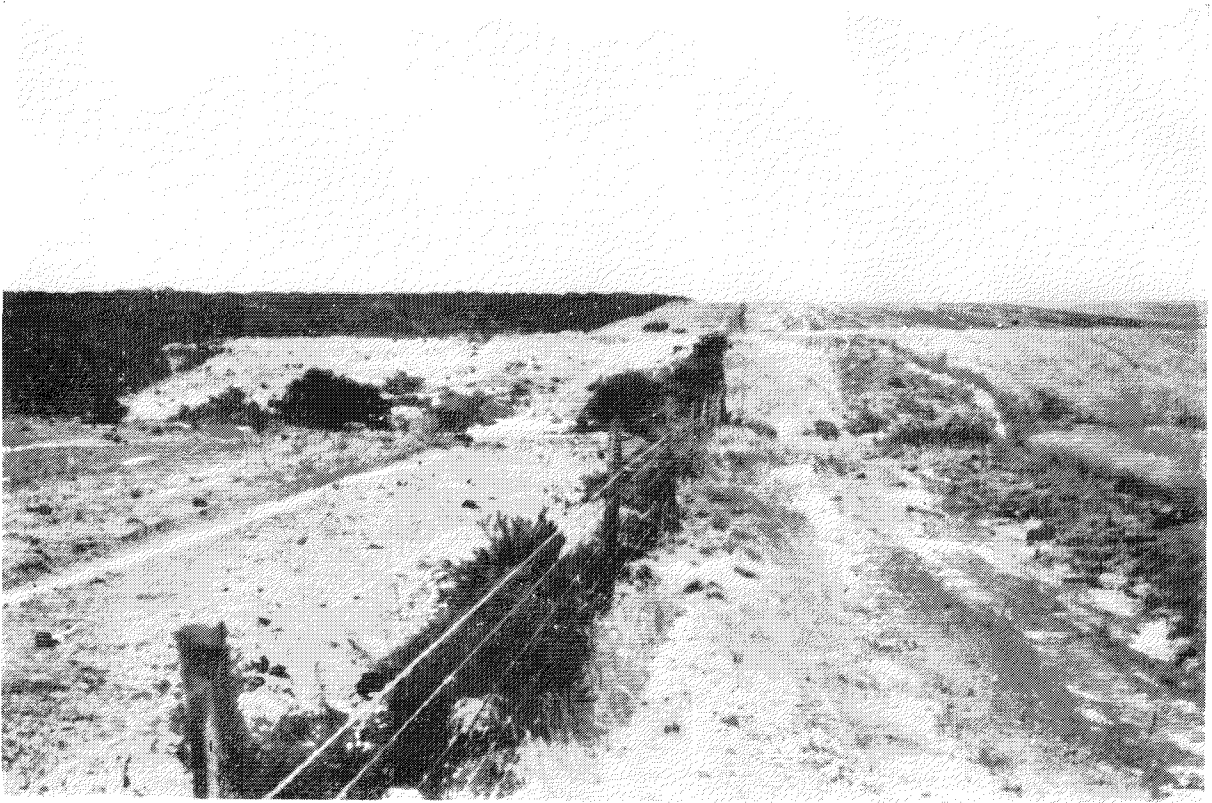
12868

B. Air-photograph showing possible sagpond caused by obstruction of creek by scarp.  
Scale : 1 : 40,000

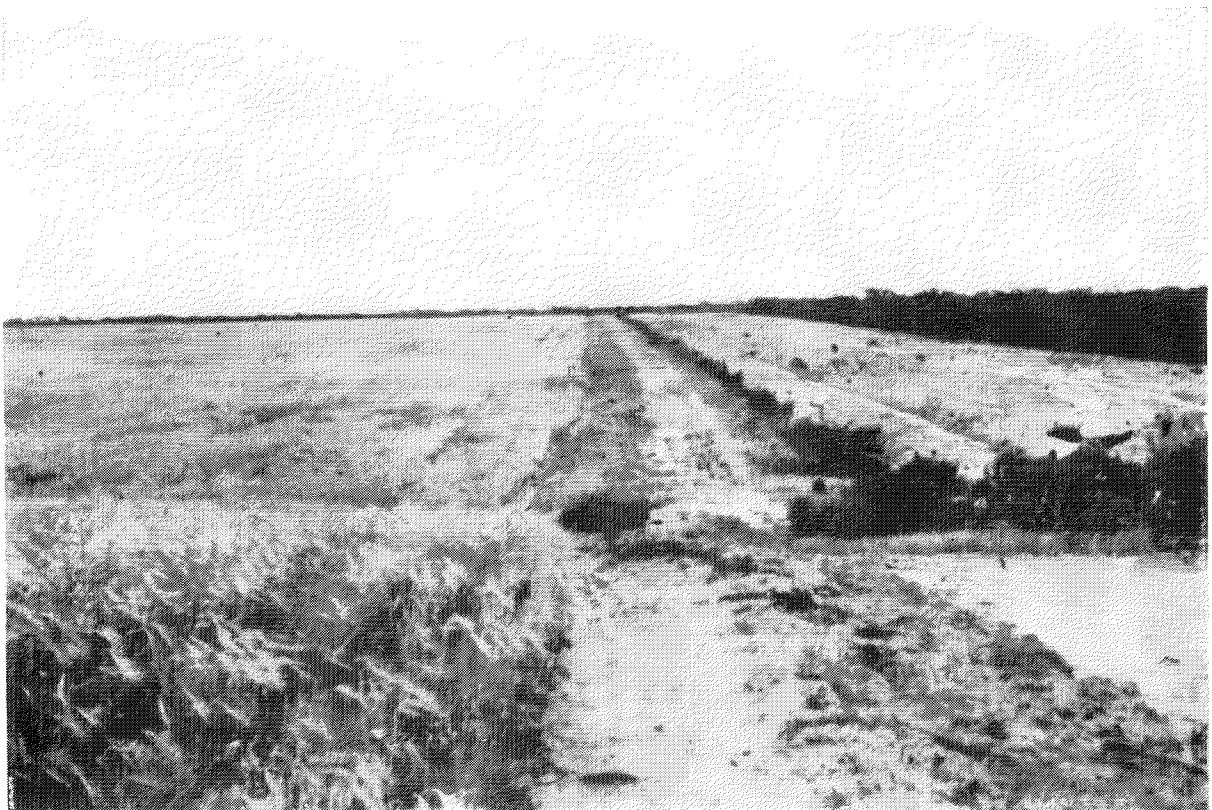


PLATE 11

A. Air-photograph showing detail of northern extremity of fault. Scale : 1 : 40,000.



A. Typical development of fault scarp (middle distance). Rise in the distance is another scarp. Location: southernmost bifurcation, seen from west.



B. Same location on west scarp looking west.

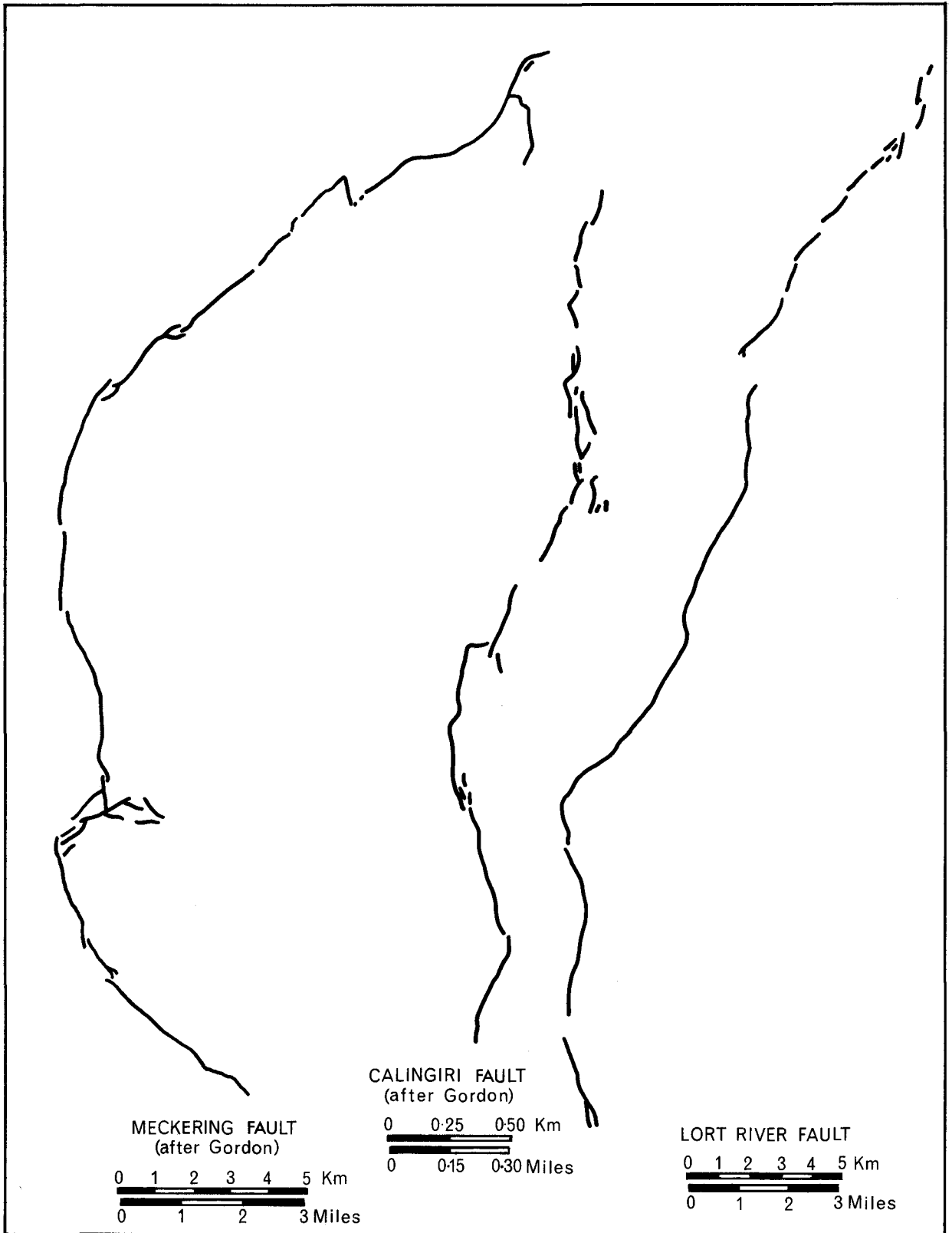
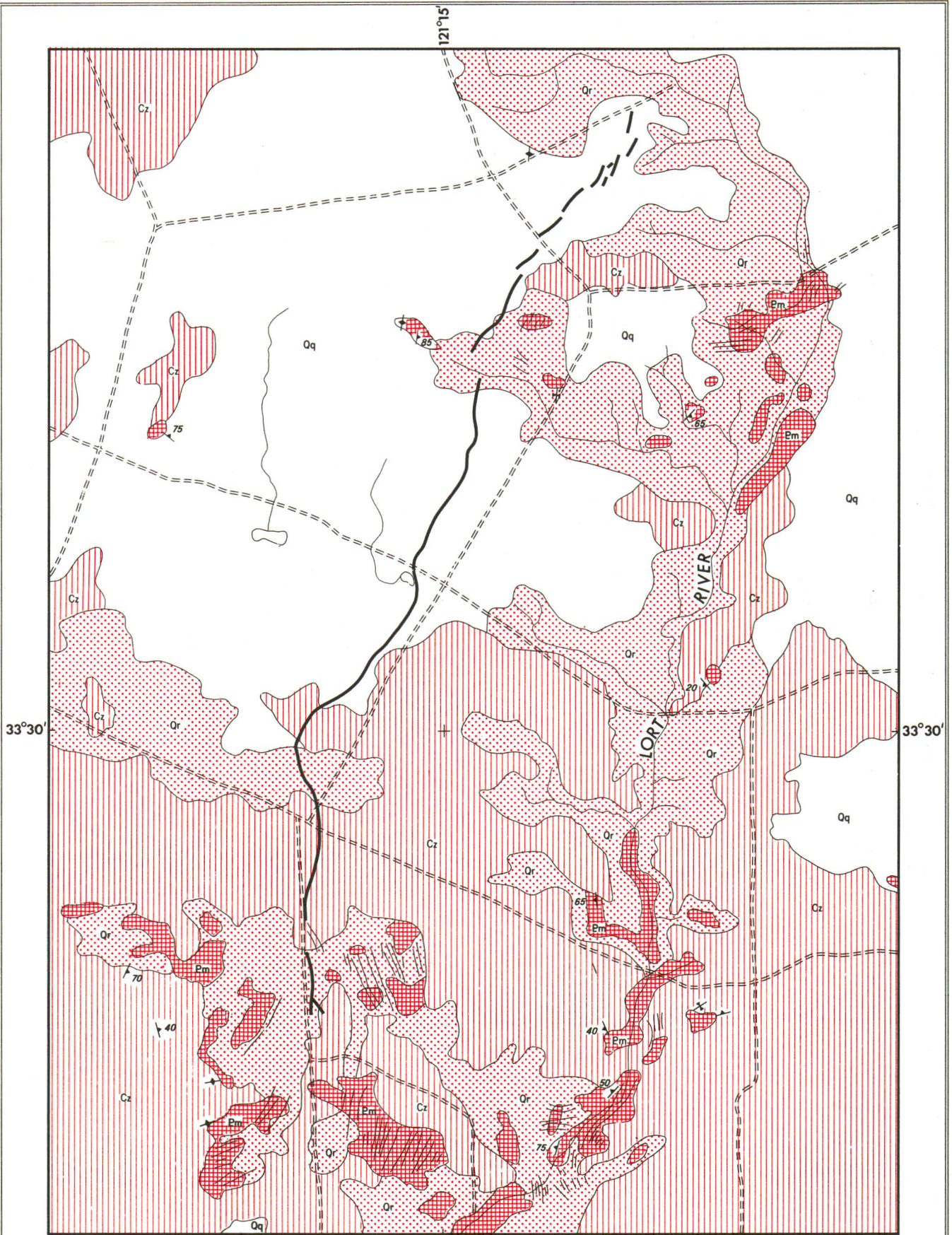













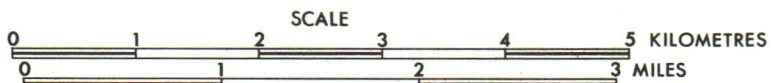
Figure 22. Comparison of fault traces.



REFERENCE

- |   |   |   |                                       |
|---|---|---|---------------------------------------|
|  | Quaternary deposits, sand to clay usually with kankar |  | Metamorphic foliation, dip unmeasured |
|  | Dissection of sandplain and erosion due to drainage   |  | Metamorphic foliation with dip        |
|  | Cainozoic sandplain                                   |  | Metamorphic foliation vertical        |
|  | Undifferentiated Proterozoic migmatites               |  | Trends from photo-interpretation      |
|   |   |  | Creek with swamp                      |
|   |   |  | Lort River Fault                      |
|   |   |  | Gravel roads, graded                  |

GEOLOGICAL SURVEY OF WESTERN AUSTRALIA  
GEOLOGY OF THE LORT RIVER AREA  
PHILLIPS RIVER GOLDFIELD



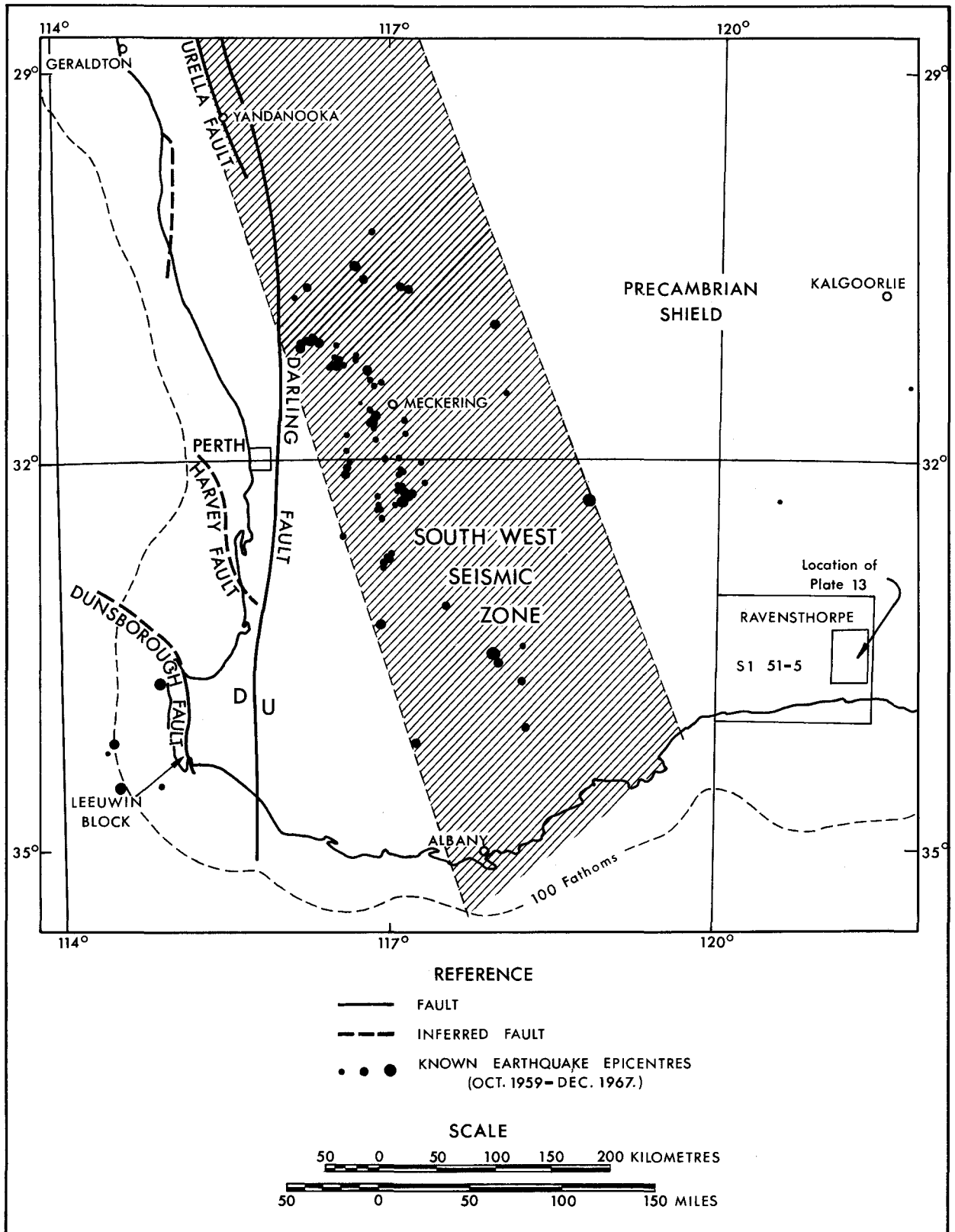


Figure 23. Location diagram showing position relative to southwest seismic zone (modified from Gordon 1972).

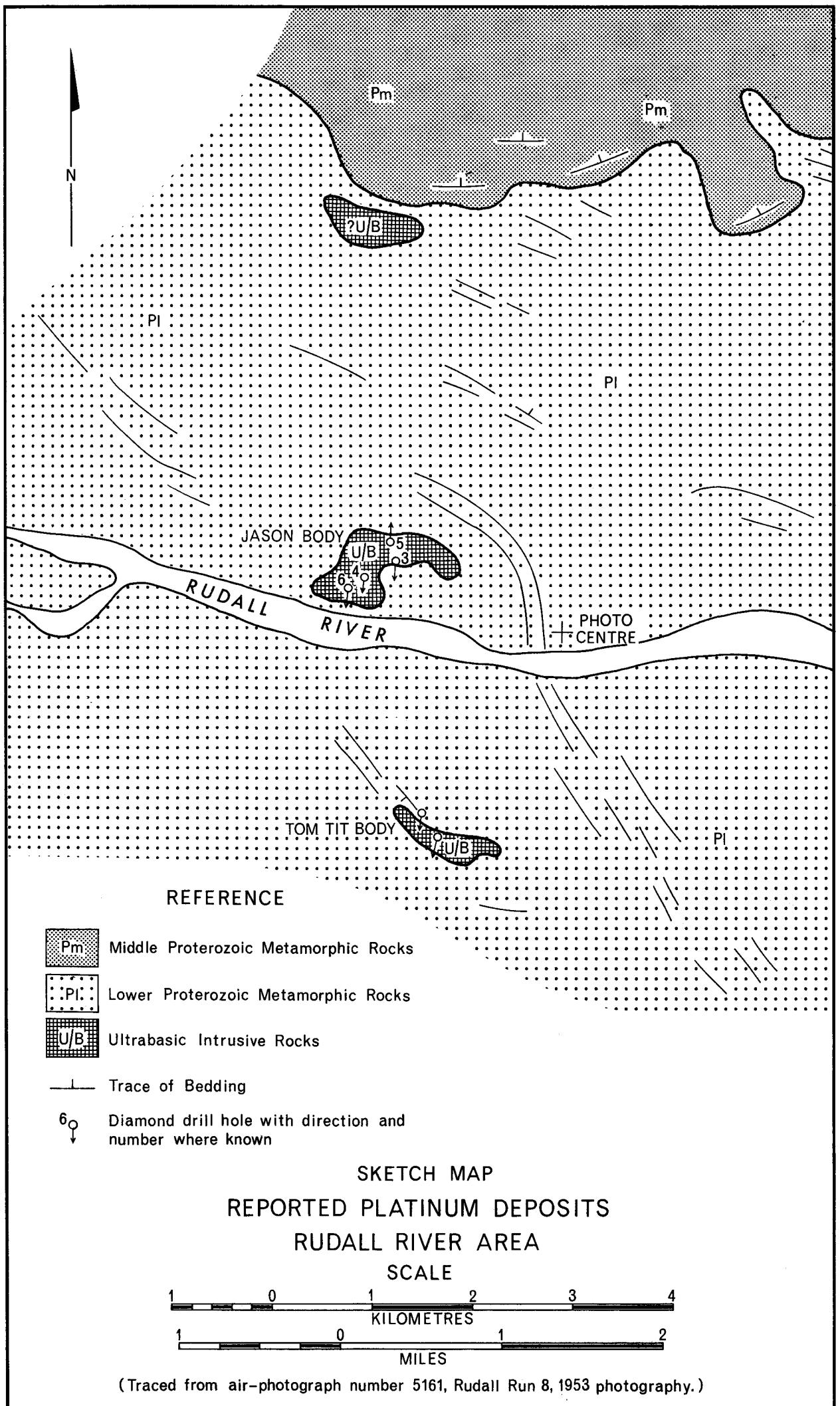


Figure 24.

The fault shows a distinct sub-parallelism to the foliations of the country rock, and may have followed these pre-existing lines of weakness. It seems possible that by so doing an unusually high scarp has resulted. The Meckering fault, which has a lower scarp, follows the country rock foliations less faithfully and in places is distinctly oblique.

#### AGE OF THE FAULT

The fault is pre-1957, as it appears on air-photographs taken in that year. Since this pre-dates settlement in the area, no buildings or roads existed to suffer damage, and it is unlikely that there were more than a few people, if any, who could have observed the effects. Some local residents have been questioned, but no earthquake tremors, apart from the Meckering earthquake, were recalled. A house standing virtually on the scarp has experienced no more effect than any other, not even during the Meckering earthquake.

That the scarp is still clearly visible may be an indication that it is fairly recent, but its deterioration has only recently been hastened by cultivation. Left to the effects of nature only, a scarp might persist for a considerable period.

The scarp has the appearance on the 1-mile mosaics of being superimposed on everything, i.e.

it seems to be the most recent feature. It cuts across drainages, and in one case a pool seems to have been formed where the scarp has obstructed the course of a creek (Plate 11B).

#### RELATION TO THE SOUTH WEST SEISMIC ZONE

The Lort River Fault lies outside the South West Seismic Zone (Fig. 23) and Balardon Tectonic Belt as defined by Gordon (1972). If the Lort River Scarp is evidence of an earthquake, perhaps comparable in magnitude to that of Meckering, it may be that present earthquake risk zones require revision and that earthquake risk in the southwest of the State may be more extensive than so far realized.

#### REFERENCES

- Gordon, F. R., 1972. Earthquake hazard in Western Australia: West. Australia Geol. Survey Ann. Rept. 1971, p. 25.  
— in prep., The Meckering Earthquake: West. Australia Geol. Survey Bull. 125.
- Lewis, J. D., 1969, The geology of the country around Meckering: West. Australia Geol. Survey Rec. 1969/18 (unpublished).

## A REPORTED PLATINUM FIND IN THE RUDALL RIVER AREA

by J. G. Blockley

#### ABSTRACT

In January 1971, significant platinum values were reported from two bodies of ultrabasic rocks intruding Lower Proterozoic metamorphic rocks in the drainage basin of the Rudall River.

Check samples of the ultrabasic rocks and of alluvial concentrates derived from these rocks showed negligible quantities of platinum when assayed by the Government Chemical Laboratories. However, some alluvial samples did contain gold.

#### INTRODUCTION

In a statement to the Sydney Stock Exchange dated January 27, 1971, North West Oil and Minerals Co. N.L. announced the discovery of a major platinum find in the little-explored Rudall River area, about 290 kilometres (180 miles) southeast of Marble Bar. The statement gave details of four drillholes giving platinum values of from 1.99 to 6.65 grams per tonne (1.30 to 4.34 dwt per ton) from the surface to depths of from 117.6 to 239.5 metres (385 to 784 ft). The assays were of random 1.53-metre (5 ft) sections in every 15.3-metre (50 ft) length of core, and were done by atomic absorption spectrophotometry. On the basis of these results, the company estimated reserves of 1,030 tonnes (33.1 million oz) of platinum in rock averaging 3.82 grams per tonne (2.5 dwt per ton) of this metal in the Jason ore body.

It was also stated that the Jason ore body was of similar composition to the major platinum deposits at Rustenburg in South Africa.

In a subsequent press release, the company announced further platinum values in two holes drilled into the Tom Tit body, south of the Jason body. After the completion of the sixth hole, exploration work closed and the camp was placed in the care of a maintenance crew. The writer inspected the area in June 1971 with the object of verifying the presence of platinum.

#### LOCATION AND ACCESS

The ultrabasic rocks from which the platinum was reported are situated close to the Rudall River at about latitude 22°35' S, longitude 122°13' E. Access from Roy Hill station homestead on the

Great Northern Highway is by graded road to Balfour Downs, station tracks to Christies Crossing on the Oakover River, and then by a two wheel track across sandy desert country to the company's camp. The road distance from Roy Hill to the camp is 346 kilometres (215 miles) and travelling time is about 12 hours.

#### FACILITIES

North West Oil and Minerals Co. N.L. have established a camp on the Rudall River a few kilometres upstream from the deposits and an airstrip a further 4.8 kilometres (3 miles) to the west. Water is obtained from soaks in the bed of the river. Food and most other supplies are flown into the camp by regular charter flight.

#### GEOLOGY

The bodies of ultrabasic rock from which the platinum values were reported are intruded as small plugs or laccoliths into a group of metamorphic rocks comprising quartzite, quartz-micaschist, and quartz-mica-feldspar gneiss (Fig. 24). Apart from the ultrabasics the only igneous rocks seen were a small outcrop of aplite, and an outcrop of syenite.

Five kilometres (3 miles) north of the ultrabasic intrusions, the metamorphic rocks are overlain unconformably by a group of interbedded quartzites and phyllites, which forms the Broadhurst Range. Age determinations carried out on the older metamorphic rocks (J. R. De Laeter, pers. comm.) suggest that they are of Lower Proterozoic age. The younger metamorphic rocks are tentatively correlated with the Middle Proterozoic Bangemall Group on the basis of their lithological similarity to other Bangemall Group rocks mapped to the west.

The younger metamorphic rocks form hills rising above the general level of the desert sandplain, but the older rocks are exposed only where the Rudall River and its tributaries have cut back into the sandplain.



The ultrabasic bodies are composed mainly of dark, massive serpentinite, in which can be seen outlines of original olivine grains. No primary layering is apparent, but where sheared the rock becomes a talc, or talc-chlorite schist. Some specimens contain flakes of brown mica, which an inexperienced observer could perhaps mistake for free platinum. These ultrabasic rocks are much less metamorphosed than their host rocks, and are therefore appreciably younger, but their exact age is unknown.

The larger Jason body crops out on the northern side of the Rudall River. It has an irregular shape, concave to the southeast, and is about 1,200 metres (4,000 ft) long and 450 metres (1,500 ft) wide at the western end. The smaller Tom Tit body is about 1.6 kilometres (1 mile) south of the river. It is lenticular, with its long axis trending southeasterly, parallel to the banding of the metamorphic rocks. It is 750 metres (2,500 ft) long and 150 metres (500 ft) across at its widest part. Other ultrabasic bodies have been pegged, but not tested at Silent Valley (near Rooney Creek) and 21 kilometres (13 miles) downstream on the Rudall River.

### RESULTS OF SAMPLING

In an attempt to check the presence of platinum in the ultrabasic rocks, chip samples were taken from the vicinity of the drillhole collars, and natural concentrates of black sands were collected from four small creeks draining the bodies. The chip samples were analyzed for platinum by a method which involved collecting the metal into a gold prill, and then analyzing it by atomic absorption spectroscopy in the presence of copper and cadmium. A summary of the method is given in the Annual Report of the Government Chemical Laboratories for 1970, in which it is stated that other methods of determining platinum by atomic absorption spectroscopy may give high values as a result of inter-element interference. The chip samples all assayed less than 0.13 ppm platinum (less than 2 gr per ton) (Table 1).

TABLE 1. ASSAY RESULTS OF CHIP SAMPLES

Sample No.	Locality	Pt grams/tonne (ppm)	Ni (ppm)
21716	Tom Tit body—near southern drillhole	<0.13	2,000
21719	Tom Tit body—near northern drillhole	<0.13	2,400
21722	Jason body—eastern near northernmost drillhole	<0.13	1,700

TABLE 2. ASSAY RESULTS OF ALLUVIAL CONCENTRATES

Sample No.	Fraction	Locality	Pt grams/tonne (ppm)	Au grams/tonne (ppm)
21717	Magnetic	From small gully cutting Tom Tit body	<0.13	<0.13
	Non-magnetic	.....	<0.13	<0.13
21718	Magnetic	1,200 feet southeast of southern drillhole on Tom Tit body	<0.13	<0.13
	Non-magnetic	.....	0.64	206
21721	Magnetic	Creek passing through centre of Jason body	<0.13	9.2
	Non-magnetic	.....	<0.13	0.32
21723	Magnetic	Creek cutting west end of Jason body	<0.13	<0.13
	Non-magnetic	.....	<0.13	0.32

NOTE: 1 gram per tonne = 0.653 dwts/long ton

The creek samples were concentrated by panning followed by bromoform separation, and divided into magnetic and non-magnetic fractions. Each fraction was examined by a petrologist for platinum minerals, and then assayed for platinum and gold. The results are listed in Table 2. One sample of a non-magnetic fraction yielded 0.64 ppm platinum (10 gr per ton) which was associated with 206.5 grams per tonne (135 dwt per ton) of gold. All other samples had less than 0.13 ppm (2 gr per ton) of platinum.

Platinum and its related metals are hard, heavy and chemically stable, and so are ideally suited to form alluvial concentrates. Placer deposits, derived from ultrabasic rocks containing disseminated platinum metals, have been worked in Tasmania. It could be reasonably expected that the erosion of a disseminated deposit of platinum of the type reported would result in readily detectable quantities of the metal in creeks cutting the deposit, especially if samples were taken from sites in which other heavy minerals had concentrated.

The 0.64 ppm (10 gr per ton) of platinum recorded from sample 21718 may have been in a natural alloy with the gold. Alternatively it could be held in solid solution in the chromite which formed an appreciable part of the sample. Data presented by Crockett (1969, p. D2) show that concentrations of several parts per million of the platinum metals can be held in chromite in this way.

### COMPARISON WITH THE RUSTENBURG DEPOSITS

The famous Rustenburg mines contain the world's largest reserves of platinum. The deposits are well documented, one of the most recent accounts being that of Cousins (1969). The platinum occurs in the Bushveld Complex, a sill-like igneous body with a spectacular layering caused by alternations of different rock types, including gabbro, norite, pyroxenite and anorthosite. The platinum is restricted mainly to one layer of pyroxenite, the Merensky Reef, which over much of its length of 250 kilometres (155 miles) is pegmatitic. The width of the reef ranges from 18 to 38 centimetres (7 to 15 in) in the Rustenburg mine, and from 2.7 to 6.1 metres (9 to 20 ft) in the Union mine.

Hence the Rustenburg platinum deposits are in distinct contrast to those reported in the Rudall River area, where the platinum was reported to be disseminated throughout bodies of serpentinite which are of uniform composition and not discernibly layered.

### CONCLUSIONS

1. The present investigation failed to confirm the existence of commercial platinum deposits in the Rudall River area.
2. Geological comparisons with the Rustenburg deposits seem to be unfounded.
3. The detection of gold in some of the concentrates confirms long-persistent rumours that this metal occurs in the Rudall River area. However, the assays presented are of greatly concentrated material, and do not reflect the grade that could be expected in the original deposits.

### REFERENCES

- Crockett, J. H., 1969, *Platinum Metals: in Handbook of Geochemistry*, (K. H. Wedepohl ed.): Berlin, Springer-Verlag.
- Cousins, C. A., 1969, *The Merensky Reef of the Bushveld Complex: in Magmatic Ore Deposits* (H.D.B. Wilson ed.): Econ. Geol. Monograph 4, p. 239-251.

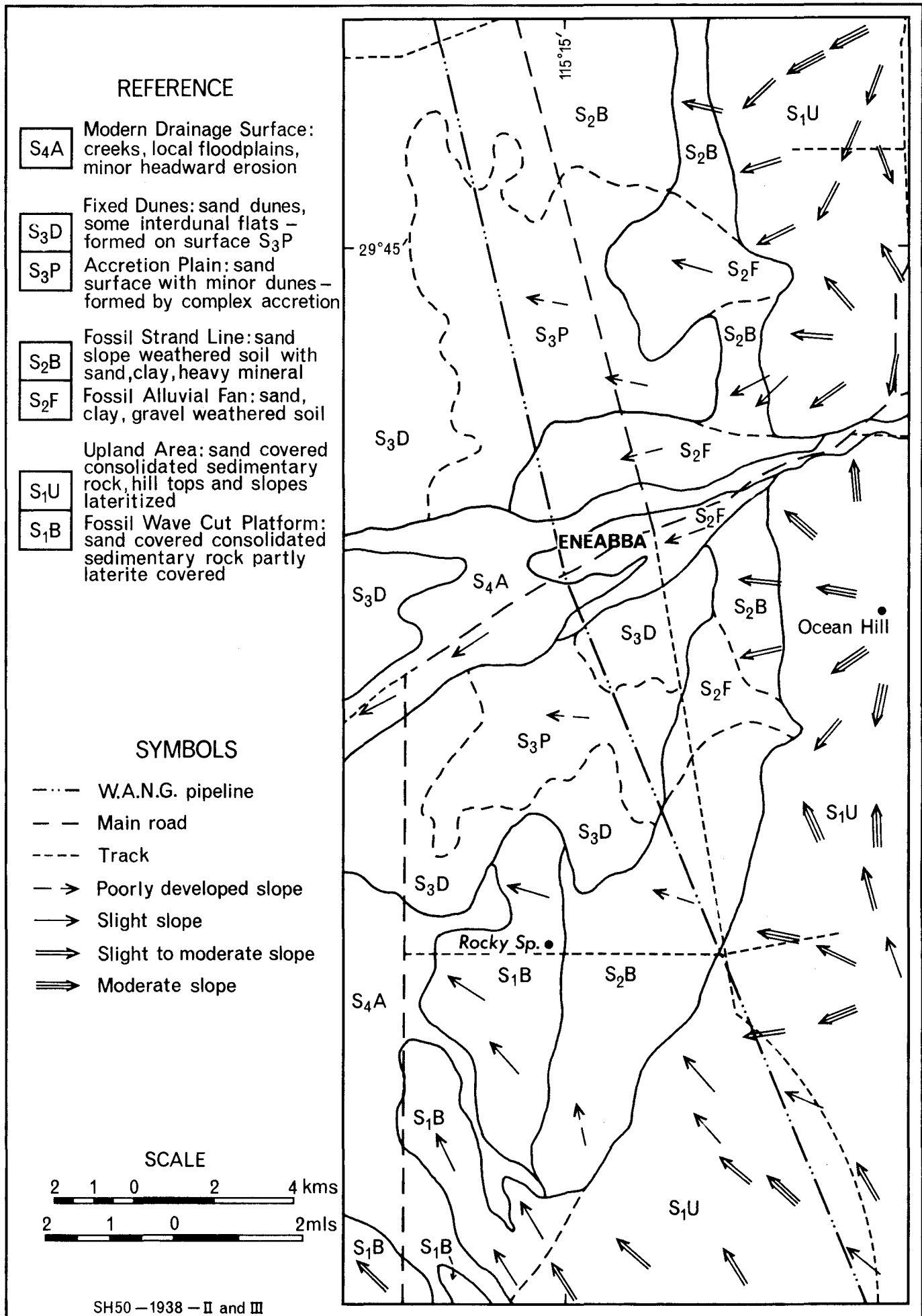
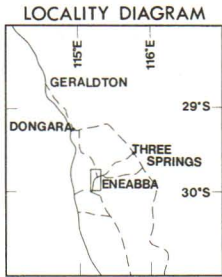




















Figure 25. Geomorphology of the Eneabba area.



REFERENCE

-  Qrw Swamp and lacustrine deposits; sand, clay, diatomite
-  Qrs Sand dunes
-  Qpa Alluvium; sand, silt, clay
-  Qpc Colluvium; quartz sand, usually thin, over Czi
-  Qpo Colluvium; quartz sand, clay over Mesozoic sediments
-  Czs Sandplain
-  Czi Laterite-ferruginous grit
-  Cre Eolian sand; deposited on sloping surface
-  Czb Beach deposits; quartz sand, clay, heavy mineral
-  Kls SOUTH PERTH FORMATION
-  Jyo YARRAGADEE FORMATION
-  Jto COCKLESHELL GULLY FORMATION

SYMBOLS

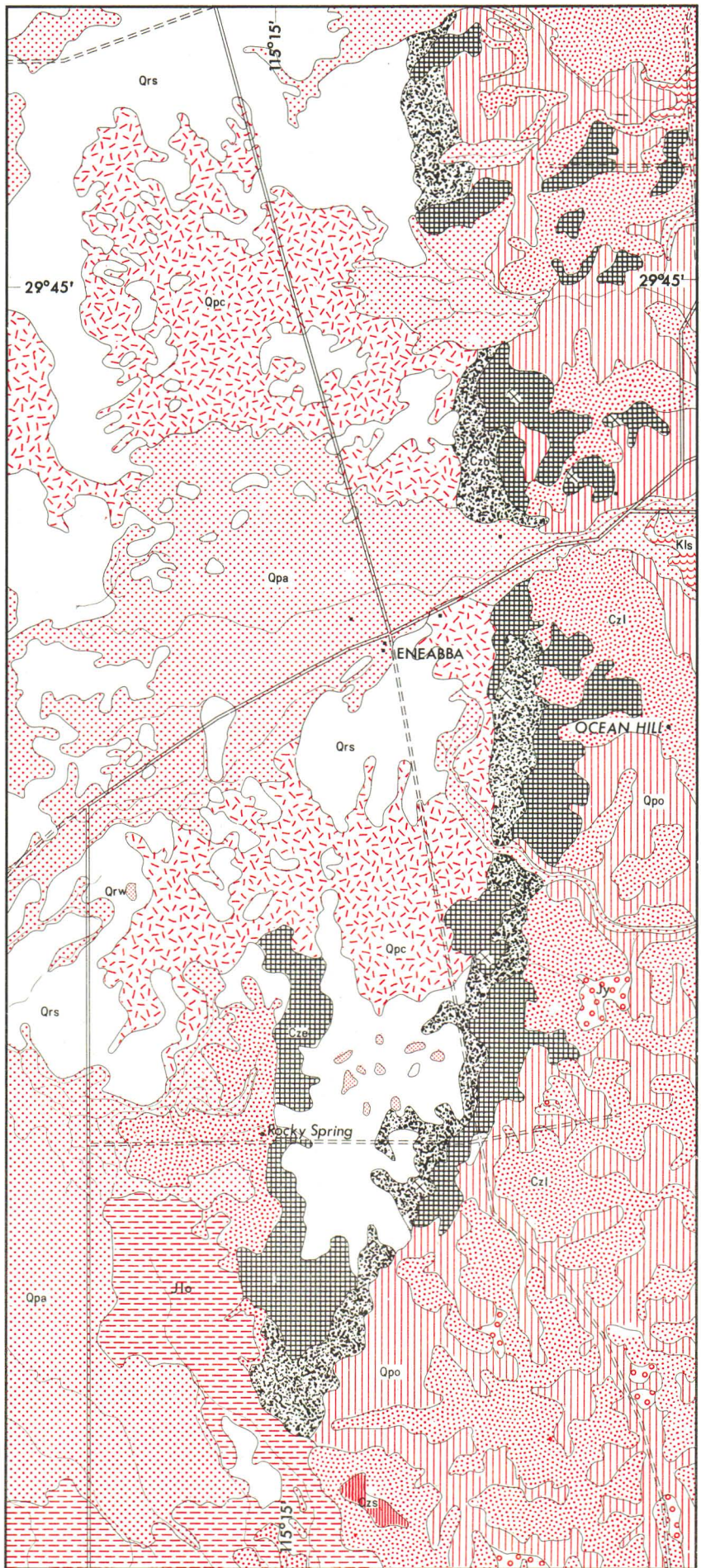
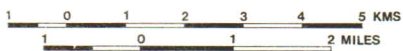
-  Geological boundary
-  Main road
-  Track
-  Building
-  Watercourse
-  Prospect

GEOLOGICAL SURVEY OF WESTERN AUSTRALIA

GEOLOGICAL MAP  
OF THE  
ENEABBA AREA

GEOLOGY BY J. L. BAXTER

SCALE



# THE GEOLOGY OF THE ENEABBA AREA, WESTERN AUSTRALIA

by J. L. Baxter

## ABSTRACT

A fossil strand line containing zones of heavy mineral concentrates is preserved at Eneabba, Western Australia. The deposit unconformably overlies Mesozoic sediments and has been deep weathered and lateritized. The immediate source of the ilmenite, zircon, rutile, kyanite and staurolite is probably the Mesozoic sediments. The mean grain size of the beach deposits is 1.9 phi units (0.26 mm), and roundness and sphericity of the quartz grains indicate that the sediment is immature.

## INTRODUCTION

The heavy mineral deposits at Eneabba came to the attention of mining companies in late 1970. The announcement of the discovery sparked off a rush in which many companies and individuals pegged ground and began investigations which consisted mainly of drilling.

The area around Eneabba was mapped by the Geological Survey in 1968 and 1969 (Lowry, 1971), and heavy minerals were recognized at Eneabba in a water bore (Peers, 1968), but no work on the deposits has been done by the Geological Survey prior to this report. Ilmenite Proprietary Limited and W. Hicks were the first to peg claims for heavy minerals and these were followed by claims pegged by several local farmers, and later by several other companies.

In December 1971, Allied Minerals N.L. announced reserves of 14.2 million tonnes (14 million tons) of heavy minerals contained in sediments with an average grade of 9.4 per cent. The heavy mineral assemblage is made up of rutile, zircon, ilmenite, kyanite, staurolite, and minor monazite. Feasibility studies are currently being carried out by Allied Minerals N.L. and Research Exploration and Management Pty. Ltd. with a view to establishing a joint mining venture in the area.

## LOCATION, ACCESS AND FACILITIES

Eneabba is in the Dongara 1:250,000 Sheet area and is 63 kilometres (39 miles) west of Three Springs, and approximately 290 kilometres (180 miles) north of Perth on the planned coastal road. The area around Eneabba is made accessible by gravel roads and sand tracks.

The townsite of Eneabba consists of a school, a store, a few houses, and a mining company office.

The West Australian Natural Gas Company's natural gas pipeline from Dongara to Perth runs through the area.

It is planned to obtain water for the mining operation from aquifers in the underlying Mesozoic rocks.

## GEOMORPHOLOGY

Figure 25 shows the geomorphological units in the Eneabba area. The units have been divided into four groups of related surfaces. The oldest surface seen in the area is an upland area with an associated wave-cut platform. These features formed the base on which a fossil strand line and an associated alluvial fan were laid down. The alluvial fans are related to drainage lines which dissect the upland areas, and form a surface at a slightly higher level than the adjacent fossil strand line. An accretion plain, on which dunes were formed, abuts the fossil strand line to the west and is dissected by modern drainage channels.

## GEOLOGY

The exposure of all rock types in the area is covered in most places by a veneer of eolian sand. Despite this, the photo-patterns of the various units are distinguishable and appear to be consistent.

The accompanying map (Plate 14) does not include this overlying sand unit. All of the rock units exposed in the area are sediments which were deposited in a continental or near-shore environment, and it is difficult to distinguish the Mesozoic basement from the younger rock units in the field.

## Mesozoic

Sediments of Mesozoic age are exposed in the upland areas and on the wave-cut bench. They are mainly sandstone, siltstone and claystone, with minor conglomerate, shale and coal measures. The sediments were formed in continental, paralic and shallow marine environments, and have been divided into three formations, namely the Cocksleshell Gully Formation, the Yarragadee Formation and the South Perth Formation.

The *Cocksleshell Gully Formation* is exposed in the southwest portion of the area mapped. It contains a sequence of sandstone, siltstone, claystone, shale and coal measures and has been divided into two members. The *Eneabba Member* consists of a sequence of red, yellow, brown, pink, purple, grey and white fine to coarse-grained sandstones with interbedded claystone and siltstone. It is overlain by the *Cattamarra Coal Measures Member*, a very fine to very coarse-grained sandstone which in parts contains coal measures. The microflora content indicates that the Cocksleshell Gully Formation is of Lower Jurassic age (Balme, 1964). It is considered to have formed in paralic and continental conditions. On the surface the rocks are deeply weathered and recognition of the component parts of the formation is difficult.

The *Yarragadee Formation* is exposed in the southern part of the mapped area. It is a bedded sequence of sandstone and siltstone with lesser amounts of shale, claystone and conglomerate. The sandstones are generally poorly sorted, and range from very coarse to very fine grained. Units within the formation are markedly lenticular, so that detailed lithological correlation is seldom possible except over short distances. It overlies the Cocksleshell Gully Formation conformably. The boundary with the overlying South Perth Formation is difficult to locate in the field, but is probably conformable. The Yarragadee Formation is considered to have been deposited in a continental environment. Exposures visited in the field are deeply weathered and consist of quartz sandstone in a clay matrix.

The *South Perth Formation* is exposed in the eastern portion of the mapped area and consists of interbedded very fine to very coarse-grained sandstone, shale and siltstone, with minor conglomerate. Units within the formation are lenticular. It is considered to have formed mainly in a continental environment with minor intercalations of marine and paralic sediments in the Eneabba area.

## Cainozoic

With the exception of laterite, rocks of Cainozoic age exposed in the Eneabba area are unconsolidated to poorly consolidated sands containing varying amounts of clay. The distinction between the units has been made primarily on photo-pattern and observations of the relative proportions of clay in the sand.

*Beach deposits and associated eolian sands* have formed on the western side of a scarp cut into the Mesozoic rocks. They contain heavy minerals which have been concentrated into an ore body south of Eneabba. The sediments contain quartz, rutile, ilmenite, zircon, kyanite, staurolite and clay. The proportion of heavy minerals varies between 0.2 and 25 per cent, and the clay content varies between 10 and 40 per cent. The physical properties of the sand are represented graphically in Figure 26. The most distinctive characteristic of the sediment is the mean grain size which is less than 1.9 phi units (0.26 mm)

in both the beach deposit and the eolian deposits associated with the beach. The roundness and sphericity results indicate that the sediments are immature.

*Laterite* crops out on the flanks and crests of hills above the 120-metre (400 ft) contour line. The laterite in this area is a ferruginous sandstone with minor pisoliths. There are several horizons of lateritized sandstones in the area, and correlation between these is not possible. The laterite capping on the hills appears to continue below the modern plain. It occurs at various depths in drillholes in the area, presumably reflecting the irregular shape of the land surface at the time of lateritization. A modern west-sloping plain between 105 metres and 60 metres (350 to 200 ft) has a lateritized sandstone approximately 1 metre (3 ft) below the surface. This laterite varies in thickness from 10 centimetres (4 in) to 2 metres (6.5 ft) and contains pisoliths. It is considered that the hill-top laterite correlates best with a ferruginous sandstone which has been intersected between 9 and 21 metres (30 and 70 ft) in drillholes. The distribution of laterite is erratic and it probably formed at various levels in the sedimentary pile since the early Tertiary. Laterite has developed on flanks of hills extending down to the coastal plain and is also found within the beach deposit, indicating that the lateritization post-dates the formation of the beach.

*Sandplain* has been identified overlying ferruginous grit, related to the laterite, on top of the hills in the south of the area mapped. The sand is white, moderately well rounded and probably no more than 3 metres (10 ft) thick.

*Colluvial deposits* are developed over the Mesozoic sediments in the hilly areas, and over a laterite on the plain. These deposits are thin, no more than 2 metres (6 ft) thick, and are composed of angular to subrounded quartz grains in a clayey-silt matrix. They generally are unconsolidated but if over 1 metre (3 ft) thick, may be partly consolidated.

*Alluvium* which probably ranges in age from early Tertiary to Recent is present along the banks of the main modern drainage channels. The deposits are composed of silt and clay with lenticular zones of fine to coarse-grained sand. The drainage channels have cut through the heavy mineral deposits south of Eneabba and contain small amounts of heavy minerals in isolated pockets. Heavy minerals carried by modern creeks have been deposited in Lake Logue and Lake Indoon (west of the area mapped) and at times can be seen in slicks along the shores of the lakes.

*Sand dunes* which have developed over all units exposed on the coastal plain are fixed by low scrub. The physical properties of the sand are shown in Figure 26.

*Swamp and lacustrine deposits* composed of sand, clay and diatomite have formed in interdunal areas. These deposits are small and are restricted to the area south of Enneabba.

## GEOLOGICAL HISTORY

The period prior to the deposition of the beach sand containing heavy minerals is not reviewed in this paper. At the time of deposition of the beach deposit, sea level was approximately 91 to 105 metres (300 to 350 ft) above modern sea level. The Mesozoic sediments were exposed along the shore of the ocean and were being eroded by youthful streams which contributed sandy material to the beach.

The coastline consisted of a north-facing bay outlined by the upland areas and the wave-cut bench shown in Figure 25. The southern end of this bay was filled with fine-grained sand and silt composed of quartz and feldspar grains as the sea level regressed due to sedimentation. When the shoreline became stable, currents, diffracted by the northern extension of the wave-cut platform, sorted the sediments and concentrated the heavy minerals.

The regressing sea was followed by a period of deep weathering which produced the major laterite horizon and reduced the feldspars to clay in both the Mesozoic sediments and the beach deposits.

Alluvial sediments and later dunes were deposited over the old beach and to the west of it, and in recent time creeks have dissected all deposits, cutting down to depths of up to 15 metres (50 ft) into the Mesozoic sediments and laterite.

## REFERENCES

- Balme, B. E., 1964, The palynological record of Australian pre-Tertiary floras in Cranwell (ed.) *Ancient Pacific Floras*: Honolulu, Univ. Hawaii Press, p. 49-80.
- Krumbein, W. C., 1941, Measurement and geological significance of shape and roundness of sedimentary particles: *Jour. Sed. Petrology* v.11, p. 64-72.
- Lowry, D. C., 1971, Explanatory Notes on the Dongara-Hill River 1:250,000 Geological Sheets: West. Australia Geol. Survey Rec. 1971/21 (unpublished).
- Peers, R., 1968, Petrological Report No. 167: West. Australia Geol. Survey File Rept. (unpublished).
- Rittenhouse, G., 1943, A visual method of estimating two-dimensional sphericity: *Jour. Sed. Petrology* v.13, p. 79-81.

# THE EDJUDINA METEORITE

by J. D. Lewis

## ABSTRACT

On the 20th of September 1969, a meteorite was found on Edjudina Station, at 29°35'11" S, 122°10'54" E, about 125 kilometres (80 miles) north-east of Kalgoorlie, Western Australia. The stone weighed 4.48 kilograms and appears to be about two-thirds of the original size. The Edjudina meteorite is a moderately metamorphosed olivine-bronzite chondrite containing about 21 per cent metal. A chemical analysis together with norm and determination of the olivine is given.

## INTRODUCTION

The Edjudina meteorite was discovered on the 20th of September 1969, by Mr. I. R. Williams, who supplied the information in the remainder of this paragraph. The location of the find is given

as 663 metres (33 ch) south of One Tree Well and about 46 metres (150 ft) west of a north-south fence line, or 29°35'11" S, 122°10'54" E. The location is situated on the Edjudina pastoral lease, within the Edjudina 1:250,000 Sheet area, and the meteorite was named accordingly (name approved by the West Australian Meteorite Committee). It was found embedded in a silty sand residual soil overlying granite, with less than half its bulk protruding through the surface. A search of the area failed to locate further pieces of the meteorite or any evidence of an impact crater.

## GENERAL DESCRIPTION AND MORPHOLOGY

The portion of the meteorite collected appears to be about two-thirds of the whole and weighed 4.48 kg. Originally the stone would have been triangular in shape with two sides slightly convex

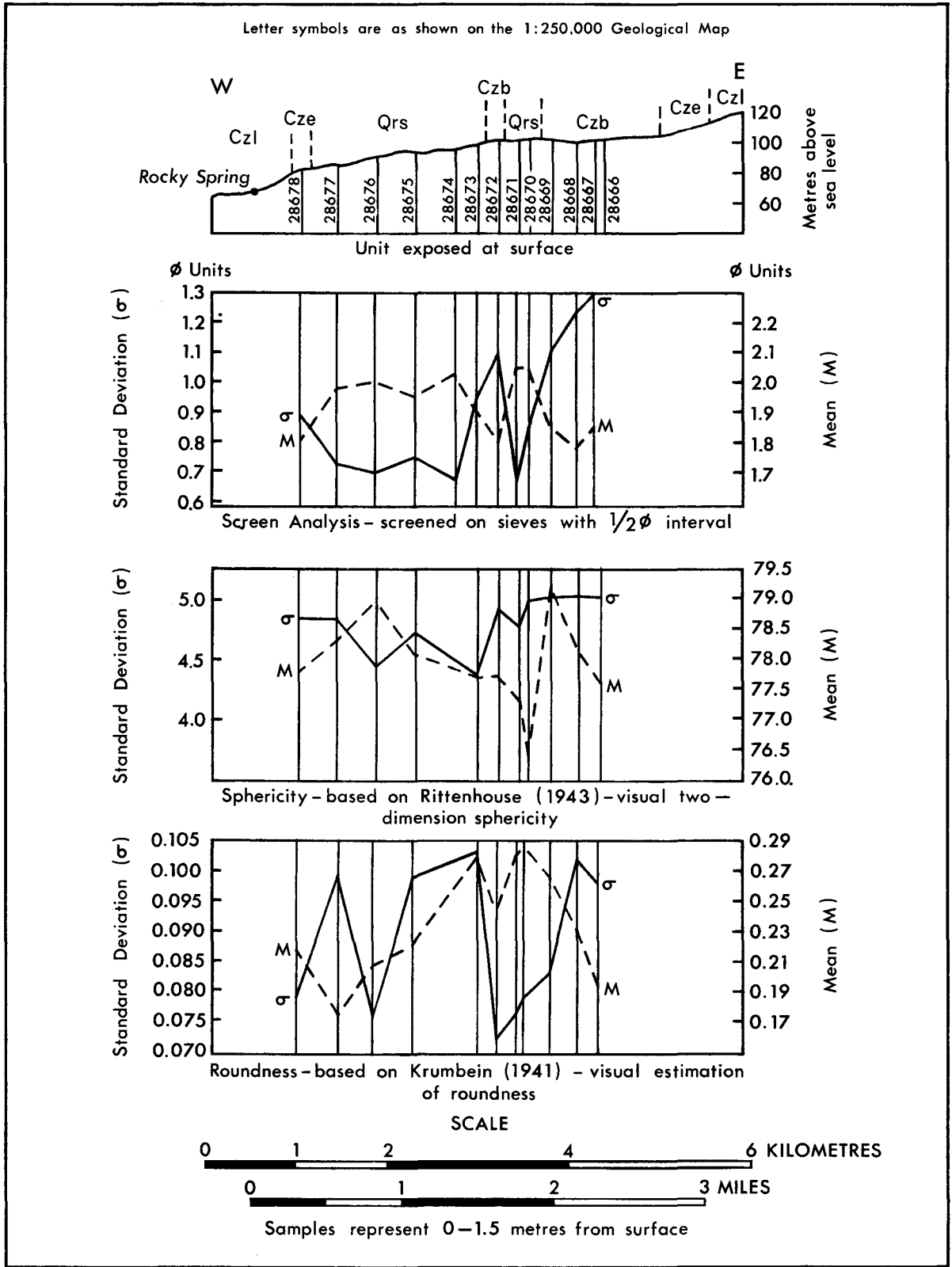


Figure 26. Physical properties of sand in the Eneabba area.

and the third slightly concave; each side is about 20 cm long and the specimen is about 10 cm deep. The meteorite shows pronounced orientation characteristics, the anterior face is convex and crudely pyramidal and the posterior is concave. About two-thirds of the surface of the specimen are covered by a slightly oxidized matte brown fusion crust which is about 0.5 mm thick on the anterior face and up to 1 mm thick on the posterior face. In places the fusion crust has broken off to reveal the underlying chondritic material which shows only superficial oxidation, probably due to weathering. At the apex of the front face the fusion crust shows several small cracks. The large fracture surface due to the breaking-off of about one-third of the meteorite shows only superficial oxidation which suggests that it broke on impact and that the remainder should be nearby.

Regmaglypts are few in number and usually shallow on the front face of the meteorite but on the posterior surface they cover much of the area.

### STRUCTURE

The chondritic nature of the Edjudina meteorite is easily seen in thin section (Plate 15E) with spherical or ovoid chondrules set in an opaque ground mass. The chondrules vary in size from about 0.5 mm to 2 mm across with occasional larger chondrules up to 8 mm in diameter. Many of the chondrules are broken and a few are polygonal; double chondrules are very rare but examples can be found of chondrules coalescing to form a dumb-bell shape, and of a small chondrule contained within a larger one (Plate 16G).

A wide variety of chondrule types is present, the commonest being microporphyritic olivine chondrules containing numerous small euhedral olivine crystals about 0.1 mm long set in a ground-mass of devitrified glass or fine needles of orthopyroxene. In some cases the olivine phenocrysts are up to 0.7 mm long and the proportion of matrix is minimal, resulting in subhedral to anhedral olivine grains. Some of the larger olivine phenocrysts are skeletal and contain inclusions of turbid or devitrified glass; occasionally the resulting crystal approaches the barred olivine in appearance.

Barred olivine chondrules (Plate 16A, B, C) are conspicuous but not numerous, the barring may be fine grained with 20 or more thin olivine plates, optically continuous, in a single chondrule, or coarse with only two or three larger olivine plates forming the chondrule. Usually barred chondrules are formed by a single olivine crystal but up to three sets of plates can be found in individuals. In such cases the individual olivines are probably randomly orientated rather than twinned (Dodd and Calef, 1971). Most of the barred chondrules are rimmed by olivine which is usually optically continuous with the central olivine plates but which may be granular and randomly orientated. It is noticeable that many of the finely barred olivines have no rim and are polygonal in outline (Plate 16B). The interstitial material of the barred olivine chondrules is often a turbid devitrified glass or fine needles of orthopyroxene, but occasionally there are clear patches of plagioclase.

Pyroxene-rich chondrules either consist of a few euhedral olivine crystals set in a mass of coarse-grained anhedral pyroxene crystals or contain only pyroxene which has crystallized as radiating feathery masses. The larger pyroxene crystals are usually anhedral but in some chondrules the crystals are stout prisms with well developed terminations. A combination of porphyritic pyroxene and barred olivine chondrules is sometimes seen, in which a coarse aggregate of pyroxene prisms is traversed by a few, optically continuous, narrow olivine plates.

Radiating pyroxene chondrules are conspicuous by their almost perfectly circular outlines, and their sharp margins. In addition the chondrules are sometimes quite large and are easily seen on the surface of both fresh and weathered material as round white spots. The degree of crystallization of the chondrules varies from extremely fine-grained feathery masses with the appearance of

devitrified glass to stout radiating prismatic crystals that show lamellar twinning. Commonly the degree of crystallization is intermediate and shows distinct plates and needles of untwinned orthopyroxene (Plate 16E).

The interchondrule mesostasis of the Edjudina meteorite consists principally of opaque minerals, but in parts also contains many fragments of olivine and pyroxene not related to any specific chondrule. The opaque nature of the mesostasis makes the outlines of chondrules in most areas quite sharp.

### Mineralogy

*Olivine* is the most abundant mineral phase of the Edjudina meteorite and is found both in chondrules and mesostasis, but principally in chondrules either as microphenocrysts or as plates in the barred olivine chondrules. Except for blebs of devitrified glass in some skeletal phenocrysts, olivine is essentially free of inclusions. X-ray determinations of olivine composition were made by the Weissenberg method and by the diffractometer method of Yoder and Sahama (1957). The crystal-line disorder of the material reduced the accuracy of the Weissenberg method and gave a composition of Fa 15±3 while the diffractometer indicated a composition of Fa 19±1. Calculation from the norm gives Fa 17.2.

*Pyroxene* occurs as large prismatic crystals and as fine radiating plates and needles principally in the chondrules. Much of the pyroxene is orthorhombic with straight extinction but the larger crystals are usually striated and appear to be twinned, the twin lamellae having an oblique extinction up to 15°. The structural disorder in the pyroxene results in X-ray powder patterns of low resolution which indicate an orthopyroxene with a composition of Fs 13±13. Calculation from the norm indicates Fs 17 and values taken together indicate a probable bronzite. Orthopyroxenes of this type are quite common in meteorites and are thought by Binns (1970) to indicate alteration from a twinned clinopyroxene. The striation is not true twinning and the extinction angle does not approach that of clinobronzite.

*Plagioclase* is observed only as small clear interstitial patches in the matrix of the chondrules and is identified only by its low relief and birefringence. The amount of plagioclase in the norm, a total of 9.2 per cent, suggests that this mineral forms much of the unresolved silica-rich material of the chondrule groundmass.

*Diopside* is probably represented by small grains of strongly birefringent material found in some radiating pyroxene chondrules, but this was not positively identified. The norm suggests nearly 4 per cent diopside but this must mainly reside in unresolved interstitial material.

*Chromite* occurs as small euhedral to subhedral grains up to 0.05 mm across, which are found principally associated with the metal and sulphide phases but occasionally as smaller grains within chondrules. The grains show high relief and are dark grey under reflected light. Part of the chromium is also present as rare grains of golden brown, transparent *picotite*, a chromian hercynite which is found in some porphyritic olivine chondrules.

*Kamacite* is the principal opaque mineral and is abundant in the interchondrule mesostasis as large cusped grains up to 1 mm across. Etching reveals that the metal is finely polycrystalline with no intergrown taenite or plessite. The metal grains have an equiaxed texture with the grain size varying from 0.05 mm to submicroscopic. The metal is unstrained and does not show Neumann bands.

*Troilite* is less plentiful than kamacite and usually occurs as slightly smaller ragged patches that reveal a coarse-grained equiaxed polycrystalline structure under crossed polarizers. The grain size of troilite is usually between 0.15 mm and 0.05 mm across, although much troilite occurs as dust-sized spherical particles surrounding some chondrules and also scattered irregularly throughout the inter-chondrule mesostasis.

Kamacite and troilite are rarely found together but occasionally the marginal troilite or kamacite is crowded with small blebs of the other phase.

Taenite was only positively identified as a few small grains, some marginal to kamacite and troilite grains. These grains etch with the properties of low nickel taenite.

#### Chemical analysis

A chemical analysis of the Edjudina meteorite, made by the chlorination technique of Moss and others (1967) is presented in Table 1. The norm and mineralogical data are shown in Table 2. Comparison with a similar analysis of the Wiluna meteorite (McCall and Jeffery, 1970) shows a consistently higher proportion of metal, sulphide and taenite in the Edjudina meteorite but the individual phases are essentially similar in composition except for the possibility of the presence of calcium sulphide in the sulphide phase. Manganese and titanium are predominantly in the silicate phase and chromium is almost completely present as chromite or silicate.

TABLE 1. ANALYSIS OF THE EDJUDINA METEORITE

Percentage Bulk Composition	
Non-magnetic attacked—	Percentage composition of sulphide phase—
Fe 3.24	Fe 61.25
S 1.94	S 36.67
Mn 81 ppm	Mn 0.05
Ca 932 ppm	Ca 1.76
Ti 29 ppm	Ti 0.05
Cr 1 ppm	
Ge 2 ppm	
Ga 2 ppm	
Cu 20 ppm	
Zn 13 ppm	
Magnetic attacked—	Percentage composition of attacked metal—
Fe 18.63	Fe 91.46
Ni 1.65	Ni 8.10
Co 0.09	Co 0.44
Si 2 ppm	
Ge 11 ppm	
Ga 4 ppm	
P 1 ppm	
Cu 6 ppm	
Zn 2 ppm	
Magnetic unattacked—	Percentage composition of unattacked metal (taenite)
Fe 0.22	Fe 61.22
Ni 0.14	Ni 38.89
Co 4 ppm	Co 0.1
Non-magnetic unattacked	Total trace element content—
SiO <sub>2</sub> 35.69	Ge 14 ppm
TiO <sub>2</sub> 0.11	Ga 12 ppm
Al <sub>2</sub> O <sub>3</sub> 2.06	Cu 26 ppm
Cr <sub>2</sub> O <sub>3</sub> 0.52	Zn 15 ppm
FeO 8.69	
MgO 23.12	
MnO 0.28	
CaO 1.58	
Na <sub>2</sub> O 0.80	
K <sub>2</sub> O 0.11	
P <sub>2</sub> O <sub>5</sub> 0.24	
C 0.04	
H <sub>2</sub> O <sup>+</sup> 0.53	
H <sub>2</sub> O <sup>-</sup> 0.14	
Ge 1 ppm	
Ga 6 ppm	
Grand total : 99.93 per cent	
Analyst : R.S. Pepper, Govt. Chemical Laboratories	

TABLE 2. NORM AND MINERALOGICAL DATA FOR THE EDJUDINA METEORITE

Norm—		Normative ratios—
Metal	20.73	An/(An+Ab+Or) : 15.6 mol. %
Troilite	5.29	Ni/(Fe+Ni+Co) : 8.6 wt. % metal fraction only
Chromite	0.77	FeO/(FeO+MnO+MgO) : 17.2 mol. % in normative femics
Ilmenite	0.22	Fe <sup>2+</sup> /Fe = 0.65 SiO <sub>2</sub> /MgO = 1.54
Apatite	0.50	Fe/SiO <sub>2</sub> = 0.81
Feldspar	9.23	Olivine composition :
{ Or 0.82		(1) b = 10.235 ± 0.015 Å
{ Ab 6.97		c = 6.000 ± 0.004 Å
{ An 1.44		Fa = 15 ± 3
Olivine	33.16	Analyst : W. M. Pryce, Govt. Chem. Labs.
{ Fa 7.76		(2) d <sub>100</sub> = 2.7785 ± 0.0005 Å
{ Fo 25.40		Fa = 19 ± 1
Diopside	3.93	Analyst : R. A. Binns, University W.A.
Hypersthene	25.39	(3) Fa = 17.2 calculated from norm
Carbon	0.04	
Water	0.67	
Sum :	99.93	
Density :	3.85	

Calculation of the olivine composition from the norm is in reasonable agreement with that found by X-ray methods. The calculated composition is Fa 17 compared with a Weissenberg determination of Fa 15 ± 3 and a diffractometer determination of Fa 19 ± 1. The discrepancy could be due to inhomogeneity of the olivine.

Both ilmenite and apatite are present in the norm of the rock but neither was observed; the small amount of both phases would be difficult to detect optically, and it is probable that the apatite occurs in the indeterminate devitrified groundmass of the chondrules.

#### Classification

Many schemes for the classification of chondritic meteorites have been devised but that of Van Schmus and Wood (1967) appears to be the most comprehensive and easily applied. Using the chemical characteristics enumerated by Van Schmus and Wood (1967, Table 1, p. 750) it is apparent that the atomic and molecular ratios tabulated in Table 2, above, fit well with those of the H or high iron group chondrites. The olivine composition of such chondrites is given as 16-20 mole per cent fayalite which also agrees with the value determined for the Edjudina meteorite.

Subdivision of the H-group chondrites is made on petrologic grounds including the presence or absence of glass, the type of pyroxene present and the degree of development of secondary feldspar. The Edjudina meteorite contains turbid glass and the pyroxene is a disordered orthopyroxene with the relict twinning of an original clinobronzite and still retaining a small extinction angle. More primitive characteristics are the polycrystalline nature of the kamacite and the lack of recrystallized prisms of plagioclase. These characteristics are indicative of a class 4 meteorite of the Van Schmus and Wood classification or a primitive recrystallized meteorite of the classification of Binns (1967).

The Edjudina meteorite is, then, an H4 or primitive recrystallized olivine-bronzite chondrite.

#### ACKNOWLEDGEMENTS

The author would like to thank Dr. G. J. H. McCall of Melbourne and Dr. R. A. Binns of the University of Western Australia for much help and encouragement during this study.

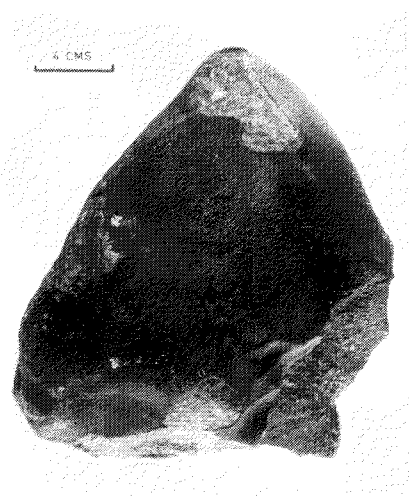
#### REFERENCES

- Binns, R. A., 1967, Structure and evolution of non-carbonaceous chondritic meteorites: *Earth and Planetary Sci. Letters* v. 2, p. 23-28.
- , 1970, Pyroxenes from non-carbonaceous chondritic meteorites: *Mineralog. Mag.* v. 37, p. 649-669.
- Dodd, R. T., and Calef, C., 1971, Twinning and intergrowth of olivine crystals in chondritic meteorites: *Mineralog. Mag.* v. 38, p. 324-327.
- McCall, G. J. H., and Jeffery, P. M., 1970, The Wiluna meteorite fall, Western Australia—2 September, 1967: *Mineralog. Mag.* v. 37, p. 888-897.
- Moss, A. A., Hey, M. H., Elliott, C. J., and Easton, A. J., 1967, Methods for the chemical analysis of meteorites: II The major and some minor constituents of chondrites: *Mineralog. Mag.* v. 36, p. 101-119.
- Van Schmus, W. R., and Wood, J. A., 1967, A chemical-petrologic classification for the chondritic meteorites: *Geochim. et Cosmochim. Acta* v. 31, p. 747-765.
- Yoder, H. S. and Sahama, Th. G., 1957, Olivine X-ray determinative curve: *Am. Mineralogist* v. 42, p. 475-491.

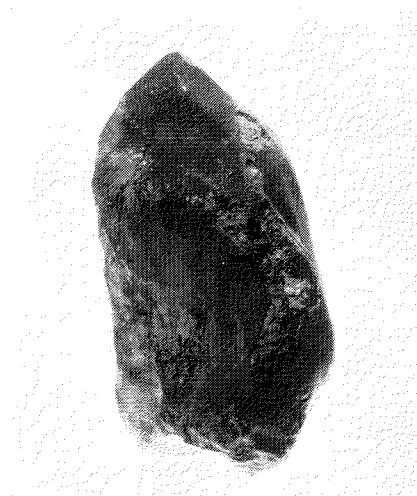
#### PLATE 15 (opposite)

- A Front view and B side view of meteorite. Note smooth fusion crust broken in parts to show chondritic material, and the concave posterior surface.
- C Reflected light photomicrograph of metal phases. Polycrystalline kamacite (strongly etched) and troilite (unetched) separated by sub-hedral grains of chromite (dark grey).
- D Intergrowth between fine-grained polycrystalline kamacite and troilite.
- E Photomicrograph (ppl) showing variety of chondrules. Note the large circular orthopyroxene chondrule (centre left) and the oval porphyritic olivine chondrule (bottom right).

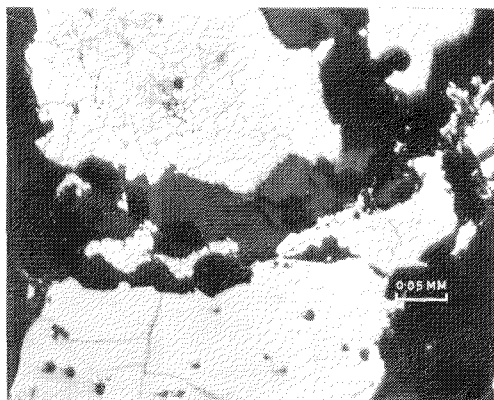




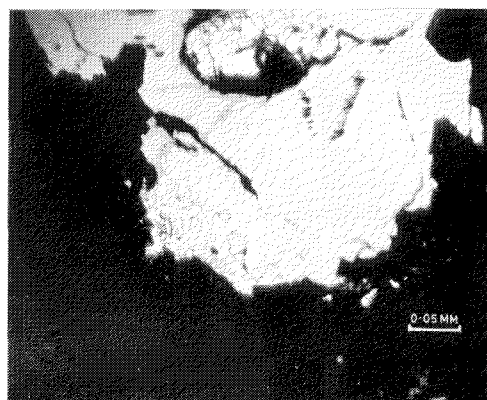
A



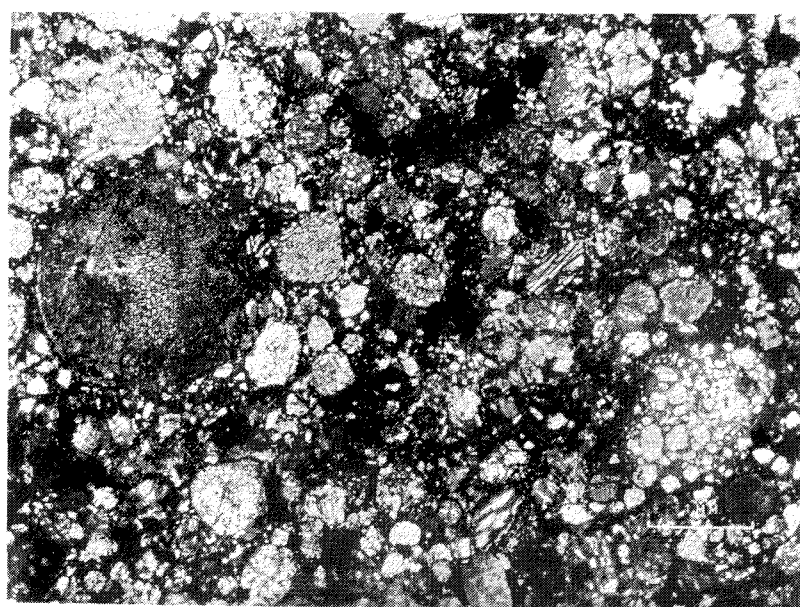
B



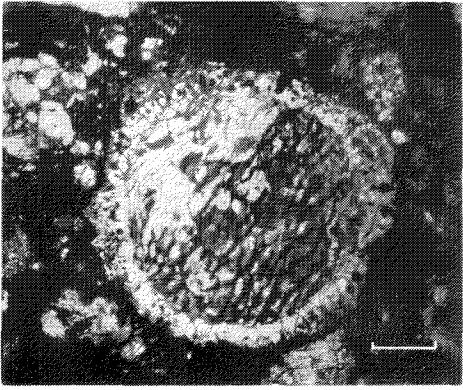
C



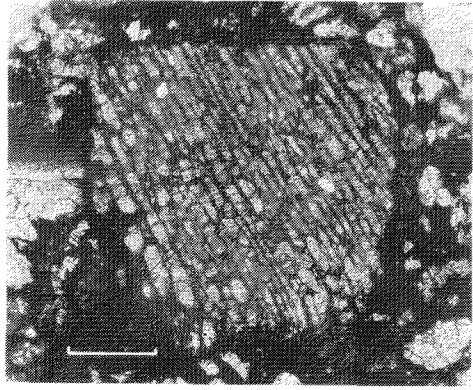
D



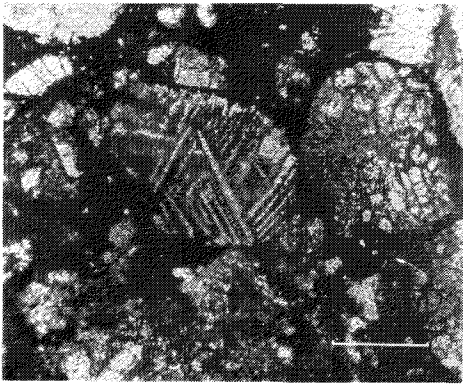
E



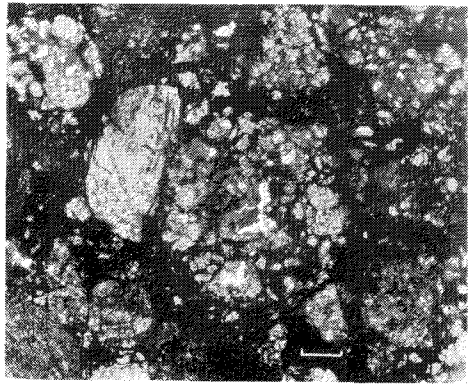
A



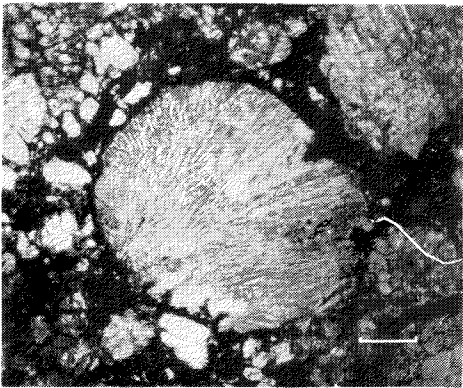
B



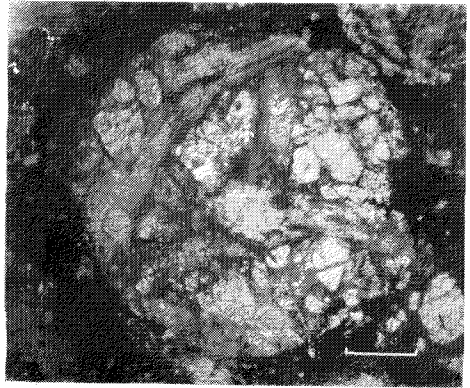
C



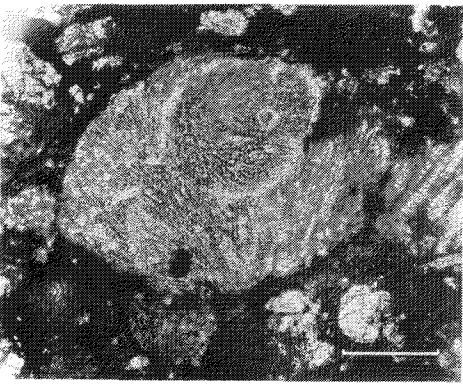
D



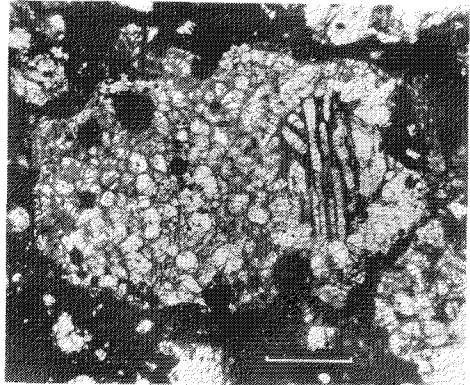
E



F



G



H

# AN UNUSUAL EUTAXITIC ROCK FROM THE PRECAMBRIAN HAMERSLEY GROUP, WESTERN AUSTRALIA

by A. F. Trendall

## ABSTRACT

A concordant stratiform body about 9 metres (30 ft) thick within banded iron formation of the Hamersley Group consists of a breccia of flat fragments derived partly from the iron formation and partly from associated acid volcanic rocks; chemical analyses show that the iron formation contributed more than half of the total bulk of the rock. The texture is eutaxitic, and many fragments of cherty iron formation show classical *flamme*\*. The rock is unusual, for one so textured, in its small volcanic component, and has particular significance in showing that the *flamme* formed by flattening during flow, rather than by *in situ* collapse of vesicular fragments, or other means.

## INTRODUCTION

The Hamersley Group forms part of the contents of the Hamersley Basin, a depositional basin which covered about 100,000 square kilometres (38,000 miles<sup>2</sup>) of what is now the northwest part of Western Australia, roughly between latitudes 21° and 24°S and longitudes 115° and 121°E, in the approximate interval 2,300 to 1,800 million years ago. The group is about 2,400 metres (8,000 ft) thick. Some 40 per cent of this thickness consists of iron formation, of which a detailed study has recently appeared (Trendall and Blockley, 1970). In the upper part of the group an acid volcanic succession, the Woongarra Volcanics, has a thickness of between 240 and 660 metres (800 to 2,160 ft). The exact manner of emplacement of these volcanics presents problems, to whose solution further field study of the upper contact, against the Boolgeeda Iron Formation, was directed during 1971.

In several localities, in widely distant parts of this outcrop area, it was found that above the concordant upper contact of the main body of the Woongarra Volcanics, successively thinner concordant stratiform bodies of breccia appear within the overlying iron formation. Wherever the breccia is coarse enough for fragments to be identified, both volcanic and iron-formation fragments are recognizable. Normally the fragments are strongly elongate parallel to the margins of each band, and the total textural effect is that normally called eutaxitic.

The purpose of this paper is not to present the stratigraphic details of the breccia bodies, nor to discuss in detail their possible origin, but to describe a single sample collected centrally within one such body, well exposed in the west bank of Nal-lanaring Creek (21°27'S; 116°10'E), to record two chemical analyses which help to identify the component fragments of the rock, and to establish a few basic points concerning the development of the described textures. The body is 9 metres (30 ft) thick, dips west at about 20°, and is separated from the top of the Woongarra Volcanics beneath by some 11 metres (36 ft) of relatively undisturbed banded iron formation of normal macroscopic appearance.

Although the rock described has a classically eutaxitic appearance, less than half of it is of volcanic derivation, and it is clear that some of its textures, normally regarded as uniquely volcanic in association, have been imposed on fragments of cherty iron formation. This demonstration is believed to justify this brief record.

## ROCK DESCRIPTION

Because of the normally weathered state of the breccia the sample described here (15640) was broken out from the fresh interior of a large joint block dislodged from the central part of the body; its exact position within the body, its facing direction, and its orientation, are not therefore known. The rock is heavy (SG. 3.27), tough, and hard with a subconchoidal fracture, and a generally dark grey colour. It is sufficiently magnetic for a hand magnet to adhere powerfully to the fresh surface. Fragments of microbanded chert, of a brick-red colour contrasting strongly with the grey matrix, are scattered unevenly through the rock. Most of those distinguishable in hand specimen are less than a centimetre in their longest dimension, but a few reach nearly 2 centimetres across. Distances of several centimetres usually separate the larger fragments. Most are elongate in cross-sectional shape and a slight preferred planar orientation of these is parallel to the general planar direction noted below. Some are equant, and in detail there is a great variety in shape from angular to rounded. Some are sharply rectangular, while others have thin streaky "tails" extending from them. Illustrated examples of different shapes are referred to farther below. Although the red chert fragments give the breccia a conspicuously spotted appearance the remaining fragments are barely distinguishable on an unprepared surface; only scattered dark green feldspars mostly 2 to 4 millimetres across are easily distinguished in the hand specimen by their cleavage faces. On a smoothly cut face, however, the homogeneous dark grey matrix appears clearly composed of a close-packed mass of wisps and streaks of slightly darker or lighter grey, mainly a few millimetres but up to several centimetres long, and with elongations between 2:1 and 20:1. These have a strong preferred parallel orientation which flows smoothly around the more equant chert fragments.

In thin section all the constituent fragments are revealed with a clarity that would not be expected from the dark and homogeneous appearance of the hand specimen. A single large section is shown in Plate 17, and details from it in Plate 18. The following description is based on these illustrations: co-ordinates used refer to Plate 17.

The large central chert fragment of Plate 17, within which the coarse microbanding runs almost perpendicularly to the streakiness of the matrix, is coloured bright red by fine hematite dust. Most of the remaining larger fragments distinguished by their paler colour than the matrix are similarly coloured, or have recognizable microbanding, or both, and are thus identifiable as modified chert pieces. There is a complete intergradation from the conspicuous red jasper colour of the large fragments, through successively paler stages of smaller fragments, to final complete clarity; only the larger fragments appear coloured in hand specimen. Note in Plate 17A the shape variation

## PLATE 16 (opposite)

Photomicrographs of chondrules (bar scale = 0.1 mm)

- A Barred olivine chondrule with rim in optical continuity with bars. Note small blebs of troilite in rim.
- B Polyhedral barrel olivine chondrule.
- C Chondrule formed by several sets of olivine bars.
- D Porphyritic olivine chondrule (centre) with a broken chondrule formed by a single twinned orthopyroxene crystal (upper left).
- E Exocentric radial chondrule of orthopyroxene.
- F Chondrule formed of subhedral porphyritic olivine (light grey) and prismatic twinned orthopyroxene (darker grey).
- G Double chondrule of orthopyroxene.
- H Double chondrule of porphyritic and barred olivine. In the latter the olivine rim is granular and not in optical continuity with the central bars. The opaque blebs are troilite.

\* In published descriptions of welded tuffs the term "flamme" is variously used to denote either: (1) any highly elongate lenticular glass fragment in a welded tuff, regardless of termination shape, or (2) such fragments which have the ragged, "frayed", multiply pointed ends commonly present, and beautifully illustrated by, for example, Bersenev and others (1961, Fig. 2) and Ross and Smith (1961, Fig. 13). This restriction is here preferred, since it is only the ragged ends which are reminiscent of flame shapes.

of the pale fragments, from flat lenticular with sharply pointed terminations (b-c-d/8, e-f/9-10, f-g/8), through flat "tiles" with one (h-i/4) or both (h-i/5, g/10) ends square, and lozenge or parallelogram shapes (c-d/7, j/6), to highly irregular streaky forms (j-k/13). The blunt end of one of the examples cited is illustrated in Plate 18D. Feathery terminations corresponding exactly in shape with the flamme of glass fragments in welded tuffs also occur. Good examples appear at j-k/10, j/9 and j-k/13, and two of these are shown at a greater magnification in Plate 18, B and C. Although the large central fragment of Plate 17 is rounded and roughly equant, the tail-like termination at i/7, emphasized in B, resembles a less extreme, and possibly developing, form of the same texture.

Microbanding, where discernible within the fragments (Plate 17), is invariably parallel to the direction of elongation in square-ended fragments (c-d/4, h-i/4, h-i/5, g/10), but in fragments with pointed ends may be either parallel (j-k-l/9) or oblique (e-f/11-12, l-m/7) to the elongation. Parallelogram-shaped fragments, such as the last example cited, may have the microbanding parallel to either the longer or the shorter sides. Microbanding within fragments is normally straight, but in some internally banded fragments (i-j/9-10; see also Plate 18B) the banding is folded.

The fragments are evenly distributed through the rock. The only evident irregularity of distribution in Plate 17 is a dark area centred on e/12 which is completely free of fragments, and resembles a distorted late fracture filled by the fine matrix.

Two other fragment types are also distinguishable in Plate 17: dark fragments and feldspar crystals. Good examples of feldspars appear at f-g/8, e/9, i/8-9, j/9 and 1/8-9; an elongate cluster of feldspars also appears spread along the general elongation direction at e-f-g/2. That at f-g/8 is shown in greater detail in Plate 18. All the feldspars are altered; normally there is extensive internal replacement by an aggregate of ferrostilpnomelane, as well as a generally patchy extinction in the outer parts. Where identifiable, it is albite. These feldspars resemble, in shape, size, and alteration, many phenocrysts in the more dacitic parts of the Woongarra Volcanics, and are referred to as phenocrysts in subsequent discussion. The string of phenocrysts at e-f-g/2 has also, among the feldspars, a few typically embayed volcanic quartz phenocrysts about 0.5 mm across. Quartz fragments elsewhere occur rarely. Very dark fragments appear in Plate 17 at j-k/8 and d-e/2-3, but few of the many other smaller examples are distinguishable from the general matrix. The latter appears at a higher magnification in Plate 18A. Such fragments, whose relative opacity is due to a greater concentration of magnetite and ferristilpnomelane, are typically more elongate and more deformed than the light fragments.

No mention has so far been made of the total, rather than cross-sectional, fragment shape. In most breccia samples the shape of most fragments is clearly disc-like with no clear preferred elongation of plan shape, but in the described sample 15640, surfaces parallel to the main plane of flattening show some signs of a preferred linear direction; however, as the orientation is not known this has not been closely determined.

It can be appreciated from Plate 17 that the total texture is eutaxitic, defining this for present purposes as having a streaked appearance due to the alternation of elongated lenses of different colour or texture, and similar to that of many welded tuffs; this definition may be considered a composite of the original definition of Fritsch and Reiss (1868) with that of the American Geological Institute Glossary (A.G.I., 1960). It is not, however, immediately clear that it is a volcanic rock, although a volcanic contribution is suggested both by its proximity to the Woongarra Volcanics and by the presence of feldspar and quartz phenocrysts. The extent of this contribution is discussed below.

In general the mineralogy of this rock is simple and uniform, and examination at higher magnification reveals little additional textural information. There is a main mosaic of quartz, of average grain diameter 5 to 20 $\mu$ , which extends throughout the fabric of the rock, and within which the textures described here are defined mainly by the relative abundance of magnetite, which occurs in sharply euhedral octahedra between 5 and 50 $\mu$  across. Ferrostilpnomelane, ferristilpnomelane, carbonate (probably dolomite), and hematite, as colouring dust, are important minor constituents, while apatite and pyrite are common within some fragments. Macroscopically conspicuous pyrite within the central fragment of Plate 17 is indicated in B, but is not discernible in the photograph of A.

#### CHEMICAL COMPOSITION

A sample (15624) of flinty black flow-banded rhyolite from the Woongarra Volcanics about 30 metres (100 ft) below their top at the locality of the described breccia was fully analyzed (together with a part of sample 15640 weighing about 500 gm, and thus reliably representative of the total rock composition. These analyses appear in columns 1 and 2 of Table 1.

TABLE 1. CHEMICAL COMPOSITIONS OF EUTAXITIC BRECCIA AND UNDERLYING RHYOLITE, WITH COMPUTED AND AVERAGE IRON FORMATION COMPOSITIONS

	1 15624	2 15640	3	4	5	6	7
SiO <sub>2</sub> .....	73.98	56.95	39.76	45.50	49.37	46.08	51.41
Al <sub>2</sub> O <sub>3</sub> .....	11.28	6.85	2.42	3.90	0.46	1.06	3.34
Fe <sub>2</sub> O <sub>3</sub> .....	0.73	15.71	30.58	25.65	24.44	19.14	28.65
FeO .....	2.42	9.47	16.46	14.13	14.90	17.56	7.66
MgO .....	0.60	2.20	3.80	3.26	2.30	3.21	2.33
CaO .....	0.51	1.17	1.82	1.62	1.95	1.71	0.64
Na <sub>2</sub> O .....	0.43	2.30			0.37	0.21	0.26
K <sub>2</sub> O .....	3.02	2.17	0.48	1.68	0.12	2.00	1.35
H <sub>2</sub> O <sup>+</sup> .....	1.07	1.20	1.32	1.29	0.59	1.19	1.93
H <sub>2</sub> O <sup>-</sup> .....	0.15	0.25	0.36	0.32	0.10	0.09	0.52
CO <sub>2</sub> .....	0.24	1.26	2.28	1.93	5.08	7.42	1.28
FeS <sub>2</sub> .....	0.07	0.21	0.36	0.30			
TiO <sub>2</sub> .....	0.50	0.24		0.07	0.03	0.07	0.16
P <sub>2</sub> O <sub>5</sub> .....	0.09	0.17	0.24	0.25	0.27	0.12	0.25
MnO .....	0.02	0.07	0.12	0.10	0.02	0.14	0.16
Total .....	100.11	100.22	100.00	100.00	100.00	100.00	100.00
Fe <sup>2+</sup> .....	0.48	10.99	21.39	17.94	17.11	13.40	20.06
Fe <sup>3+</sup> .....	1.88	7.36	12.79	10.98	11.59	13.68	5.95
Total Fe <sup>2+</sup> .....	2.36	18.35	34.18	28.92	28.70	27.08	26.01
Fe <sup>2+</sup> /Fe <sup>3+</sup> .....	0.26	1.49	1.67	1.63	1.48	0.98	3.37

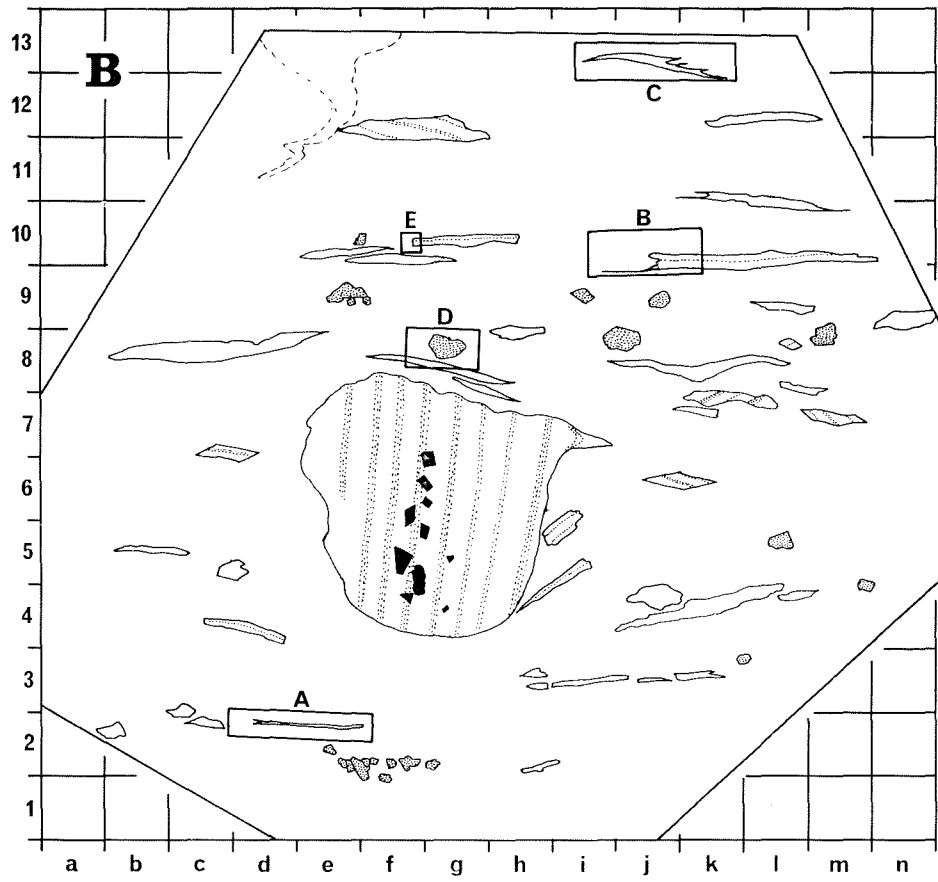
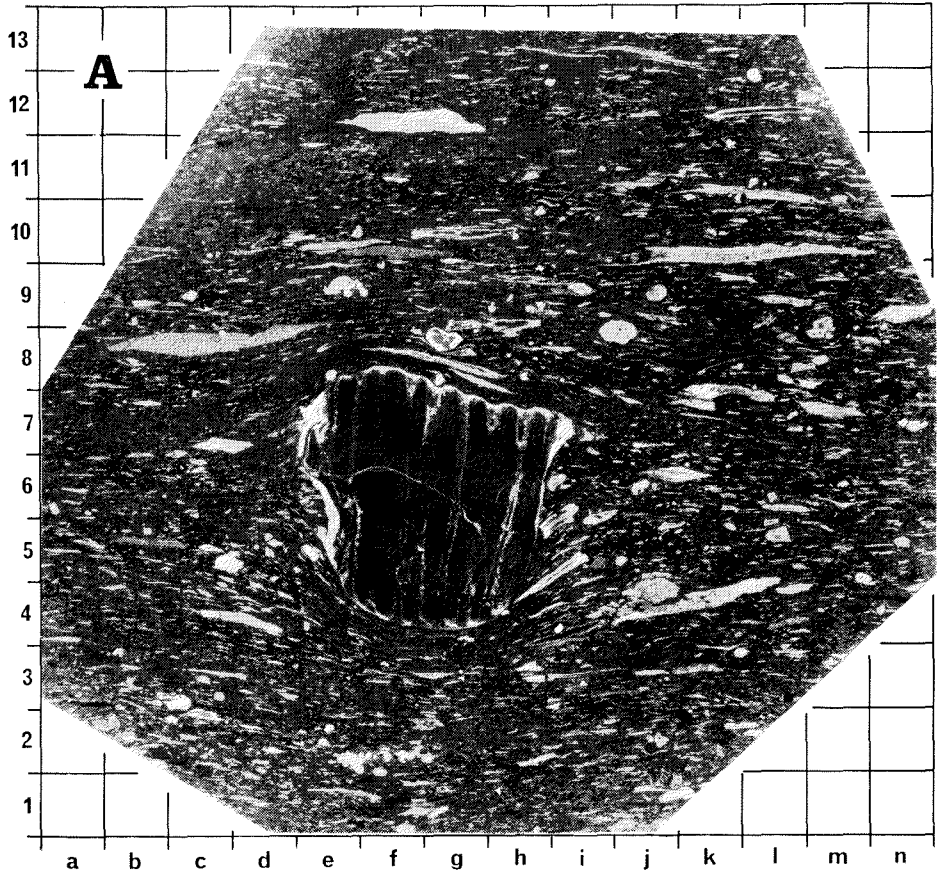
Analyst for columns 1 and 2: R. S. Pepper

#### Key to columns

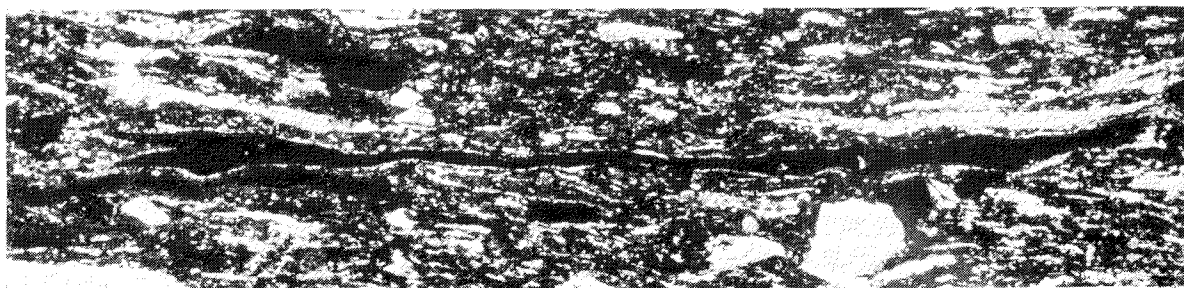
- (1) 15624. Black flow-banded rhyolite of Woongarra Volcanics. Nallanarring Creek (21°27'S; 116°10'E)
- (2) 15640. Eutaxitic breccia interbedded with Boolgeeda Iron Formation close to base. Nallanarring Creek (21°27'S; 116°10'E)
- (3) Column 2 after subtraction of 50 per cent of column 1, recalculated to 100 per cent
- (4) Column 2 after subtraction of 40 per cent of column 1, recalculated to 100 per cent
- (5) Average iron formation of Dales Gorge Member of Hamersley Group (Trendall and Blockley, 1970, Table 17)
- (6) Average iron formation of Joffre Member of Hamersley Group (Trendall and Blockley, 1970, Table 17)
- (7) Average Boolgeeda Iron Formation (Trendall and Blockley, 1970, Table 17)

#### PLATE 17 (opposite)

A and B. Photograph and traced sketch, respectively of a single large thin section of sample 15640 cut across the main planar structure. A corresponding set of marginal co-ordinates is provided in both A and B to facilitate reference in the text description. In B, microbanding within chert fragments is indicated by diagrammatic stippling, while feldspar "phenocrysts" are distinguished by close stippling. The solid black areas within the central fragment of B represent pyrite. The rectangular outlines marked by the letters A-E in B show the positions of the five areas shown in greater detail in Plate 18.



2cm.



A

2 MM



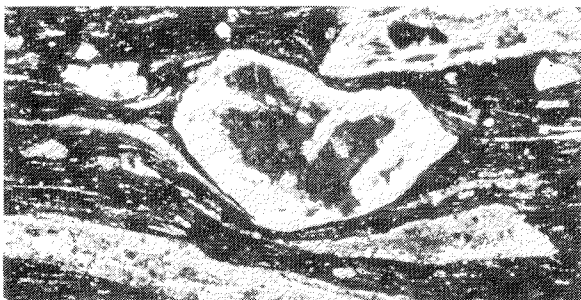
B

2 MM



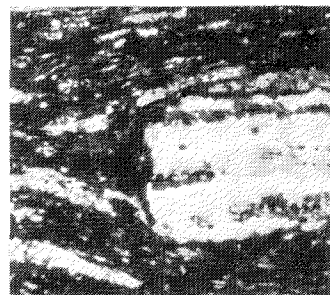
C

2 MM



D

2 MM



E

1 MM

Since silica and iron oxides jointly comprise over 80 per cent of all iron formations of the Hamersley Group it is evident from these two analyses that, supposing 15640 to be a mixture of iron formation and volcanic material, most of its iron must have come from the former, and most of its alumina from the latter. Both point to an approximately equal mixture of the two, and the result of a recalculation of 15640 to 100 per cent after removal of 50 per cent of 15624 appears in column 3. In this manipulation soda and potash are taken together as total alkalis: the soda-potash ratio varies widely within the Woongarra Volcanics within a fairly stable total.

In columns 5, 6 and 7 are shown the best available average compositions of three stratigraphic units of iron formation from the Hamersley Group. Column 3, the theoretical iron formation needed to make up the remainder of 15640 if half consists of 15624 (column 1), differs substantially from any of these average iron formations in both silica and total iron, as well as in several minor constituents. A fairly constant total iron content seems to be a feature of Hamersley Group iron formations, and in column 4 a further theoretical composition is shown, of the iron formation needed to make up the remaining 60 per cent of 15640 if only 40 per cent is contributed by a volcanic rock like 15624. Although both silica and total iron remain slightly beyond the range of columns 5 to 7 virtually every constituent is now matched with reasonable credibility: silica is close to column 6, alumina to column 7, total iron and its oxidation state to column 5, and so on. It is concluded that 40 per cent is the most likely volcanic contribution to the described breccia, although the number of assumptions needed makes it unlikely that great accuracy can be attached to this estimate.

#### DISCUSSION

Although the last two decades have produced a wealth of published descriptions of eutaxitic rocks, often accompanied by genetic speculation, there is still no common agreement on the exact means by which the elongate fragments which define the texture acquired their characteristic shape. In fact, opinions vary over a wide range, which includes the following suggestions:

- (1) they were formed essentially by the flattening and compaction, *in situ*, and after emplacement of the tuff, of highly-porous pumiceous lapilli, as the result of both the structural collapse of the vesicular pumice and the gradual elimination of intergranular pore space associated with welding (Ross and Smith, 1961, p. 24-46);
- (2) they originated by direct eruption of highly viscous pieces of liquid lava (Shirinian, 1961; Bersenev and others, 1961);
- (3) they are flow textures which formed by deformation of fragments during bulk laminar flow of lava-like material (Fremd, 1961; Schmincke and Swanson, 1967);
- (4) they result from uneven devitrification of initially homogeneous tufflava (Keegai, 1961).

In the rock described in this paper most of the lenticular fragments defining the eutaxitic texture are evidently derived from microbanded chert originating from the iron formation. The primary material was therefore neither vesicular, liquid, nor glassy, as would be required for alternatives 1, 2 and 4 respectively to apply. Among established hypotheses there remains the alternative that the eutaxitic texture of 15640 is a flow texture, and the consistency of this with textural details needs to be examined. It is known (Trendall and Blockley, 1970, p. 167-169) that cherts of Hamersley Group iron formations are prone to both plastic deformation and brittle disruption in a variety of structural situations that arose during or before complete compaction. A common form of stratigraphically restricted brecciation within some chert mesobands (Trendall and Blockley, 1970, Fig. 45) involves small-scale disruption of microbanded chert into flat, sharply rectangular tile-like forms.

The abundance of square-ended pieces in the described rock suggests that many of the fragments initially possessed an elongation by virtue of their derivation in this way, presumably as part of the unknown volcanic event connected with their intimate intermixture with igneous material. However, the existence of a variety of degrees of obliquity of microbanding in many lenticular fragments seems more credibly attributed to the deformation, by simple shear, of fragments which were similarly fractured along or perpendicularly to the microbanding, than to random brecciation of these strongly structured cherts. Flattening after fracture is also suggested by the extreme elongation of many fragments, and it seems likely that most fragments, even if originally flat, have suffered some further elongation during imposition of the eutaxitic texture. The exact mechanism of formation remains puzzling, however.

Most of the smaller fragments of the rock have clearly behaved with remarkable (for chert) plasticity, and their behaviour contrasts strongly in this respect with the larger pieces (Plate 17). Schmincke and Swanson (1967, p.658-661) suggested various reasons why the fragments in the eutaxitic ash-flow tuffs which they described from Gran Canaria apparently possessed unusually low viscosities. These include high Fe/(Si+Al) ratio of the material, high alkali contents, high Na/K ratios, high temperatures, and possibly high volatile content. It is premature to speculate whether any of these are significant in attempting to explain the similar textural features of this very differently composed rock. However, it is reasonable to suggest that the different plastic behaviour of large and small pieces may be related to a low near-surface viscosity of all the cherty fragments derived, via some such factors as these, from the enclosing matrix. That the fragments possessed a marginal rim of significantly lower effective viscosity is perhaps suggested by the "tail" of the central fragment of Plate 17, at 1/7. However that may be, the presence of such a rim seems to be the most likely hypothesis for the development of the flammé, by extreme preferential elongation of the upper and lower margins of flat fragments during total flattening. Whatever factors did control fragment viscosity they clearly did not operate for feldspar and quartz phenocrysts, none of which show the slightest sign of plastic deformation.

It is not suggested that all flammé textures, in rock of totally igneous derivation, should have interpretations of their origin restricted by the same considerations that must apply in this case, but it is nevertheless of interest to record one example where some possibilities can be confidently excluded.

#### REFERENCES

American Geological Institute, 1960, Glossary of geology and related sciences: Am.Geol.Inst., Washington.

PLATE 18 (opposite)  
Photographs of selected textural details of the thin section shown in Plate 17

- A Highly elongate dark fragment, composed mainly of magnetite and ferristilpnomelane. Note the bifurcated, flammé termination.
- B Flammé termination of large pale chert fragment. Note the parallel top and bottom edges of the fragment, parallel also to the internal structure and the extreme relative elongation of the lower (in the photograph) projection. In the upper right central part of the photograph a large banded fragment shows folding of the banding.
- C Multiple flammé terminations giving a frayed appearance to one of the larger chert fragments.
- D Undeformed albite phenocryst, centrally replaced by stilpnomelane, around which more plastic chert fragments have been moulded during deformation.
- E Square termination of a flat parallel-sided chert fragment in which the internal microbanding is parallel to the upper and lower sides.

- Bersenev, I. I., Buryanova, I. Z., Kasyan, E. D., and Licht, F. R., 1961, Tufflavas of southern Sikhote-Alin: Akad. Nauk. SSSR. Lab. Vulkan., Tr. vyp. 20, p. 136-142 translated in Cook, E. E. (ed.), 1966, Tufflavas and ignimbrites: Elsevier, New York.
- Fremd, G. M., 1961, Morphological types of ignimbrites and tufflavas from southern Kazakhstan: Akad. Nauk. SSSR. Lab. Vulkan., Tr. vyp. 20, p. 177-187 translated in Cook, E. E. (ed.), 1966, Tufflavas and ignimbrites: Elsevier, New York.
- Fritsch, K. V., and Reiss, W., 1868, Geologische Beschreibung der Insel Tenerife: Winterthur, Verlag von Wurster & Co., 494 p.
- Keegai, V. A., 1961, Tufflavas of the Tetyukhinsk region: Akad. Nauk. SSSR. Lab. Vulkan., Tr. vyp. 20, p. 157-160 translated in Cook, E. E. (ed.), 1966, Tufflavas and ignimbrites: Elsevier, New York.
- Ross, C. S., and Smith, R. L., 1961, Ash-flow tuffs: Their origin, geologic relations, and identification: U.S. Geol. Survey Prof. Paper 366, 81 p.
- Schmincke, H-U., and Swanson, D. A., 1967, Laminar viscous flowage structures in ash-flow tuffs from Gran Canaria, Canary Island: Jour. Geology, v.75 (6), p. 641.
- Shirinian, K. G., 1961, Ignimbrites and tufflavas (principles of classification and conditions of formation particularly in Armenia): Akad. Nauk. SSSR. Lab. Vulkan., Tr. vyp. 20, p. 47-60 translated in Cook, E. E. (ed.), 1966, Tufflavas and ignimbrites: Elsevier, New York.
- Trendall, A. F., and Blockley, J. G., 1970, The iron formations of the Precambrian Hamersley Group, Western Australia, with special reference to the associated crocidolite: West. Australia Geol. Survey Bull. 119, 366 p.

## APPARENT AGE, AND ORIGIN, OF BLACK PORCELANITE OF THE JOFFRE MEMBER

by A. F. Trendall and J. R. De Laeter\*

### ABSTRACT

The Joffre Member of the Brockman Iron Formation, within the Hamersley Group, in the north-west part of Western Australia, is 366 metres (1,200 ft) thick and consists essentially of banded iron formation. Its depositional age is known, from concordant acid volcanics higher in the group, to be greater than about 2,000 m.y. The Joffre Member contains rare thin bands of black glassy "porcelanite", believed to be lithified subaqueous ash-fall tuff initially made up of about 10 per cent rhyolitic glass, 60 per cent potassic feldspar crystal debris and 20 per cent quartz debris; the remaining 10 per cent of the material was taken out of the basin water by the glass. Rubidium-strontium analyses of four total rock samples of this material, and one of the iron formation, yielded a well-defined but anomalously young isochron of  $1,724 \pm 32$  m.y. Two further analyses, of an acid leach from the porcelanite with lowest rubidium-strontium ratio, and of the insoluble residue, gave widely separated points reinforcing virtually the same line ( $1,720 \pm 25$  m.y.;  $R_i 0.8114 \pm 0.0037$ ). It is not known whether this age, at which the mobility of radiogenic strontium became abruptly restricted, is that of an "event", or of the termination of a set of conditions which had prevailed since shortly after deposition, but in either case it seems likely to have geological significance.

### INTRODUCTION

This paper is the fourth resulting from a cooperative geochronological programme, initiated in 1968, between the Western Australian Institute of Technology and the Geological Survey of Western Australia. The reported work was carried out on concordant bands of unusual tough black "porcelanite", believed to represent lithified ash-fall tuff, within a banded iron formation of the Hamersley Group, in the North West Division of the State. These rocks were known to be rich in potassic feldspar, and it was hoped that rubidium-strontium analyses would define an isochron representing the age of diagenesis, hopefully close to deposition. The age of 1,720 m.y. obtained from the resultant very precise isochron was about 300 m.y. younger than the minimum age of deposition; although the objective of the project was not achieved, the results provided valuable evidence for the post-depositional history of the contents of the Hamersley Basin.

### ACKNOWLEDGEMENTS

Mr. W. W. Thomas and Mr. I. D. Abercrombie of the Department of Physics, Western Australian Institute of Technology were responsible for the X-ray fluorescence analyses and the chemical work respectively. We are also grateful to Dr. S. S. Goldich, of Northern Illinois University, for suggesting the application of acid leaching during discussion of preliminary results in May, 1970.

### GEOLOGICAL AND GEOCHRONOLOGICAL SETTING OF THE ANALYZED MATERIAL

The iron formations of the Hamersley Group have been the subject of a thorough recent study (Trendall and Blockley, 1970), to which the reader is referred for a detailed account; only a sufficient summary is given here to make this present paper comprehensible in isolation.

The Proterozoic Hamersley Basin developed by the depression of an even surface eroded across Archaean rocks. It was probably ovoid, with an east-west elongation, and covered an area of at least 100,000 square kilometres (38,000 miles<sup>2</sup>) of what is now the northwest part of Western Australia, between approximate latitudes 21° and 24°S and longitudes 115° and 121°E. This great depositional basin probably reached a central depth of about 7 kilometres (23,000 ft). The contents have survived to the present in a remarkably undisturbed and unaltered condition, with sufficient uplift for later dissection to have provided fine exposure. They are now collectively termed the Mount Bruce Supergroup, which is divided into three groups. The lowest and oldest, the Fortescue Group, consists largely of volcanic material. The central Hamersley Group, which succeeds it, is characterized by abundant iron formation, while the uppermost Wyloo Group has a mixed sedimentary and volcanic content.

The Hamersley Group, with a usual thickness of about 2,400 metres (8,000 ft), is made up of eight named formations. Of these, the Brockman Iron Formation, fifth from the base, and the Woongarra Volcanics, seventh from the base, each occupy over a quarter of the total thickness and are separated by about 120 metres (400 ft) of sedi-

\* Department of Physics, Western Australian Institute of Technology.



ments, and usually also by about 300 metres (1,000 ft) of intrusive dolerite in several sills. The Brockman Iron Formation is subdivided into four members, which are named, from base to top: Dales Gorge Member (142 metres or 466 ft), Whaleback Shale Member (70 metres or 230 ft), Joffre Member (366 metres or 1,200 ft) and Yandicoogina Shale Member (65 metres or 214 ft).

Both the Joffre and the Dales Gorge Members consist essentially of banded iron formation, in which chert bands (mesobands) between 1 and 50 mm thick alternate with bands of "chert-matrix" of about the same thickness. This latter material is a fine-grained aggregate of various iron-bearing minerals (magnetite, hematite, stilpnomelane, ankerite, siderite) in a fine quartz mosaic. The chert mesobands also usually contain either hematite, iron-bearing carbonates, or stilpnomelane, often arranged in thin regular laminae (microbands). According to the defining mineral of the microbanding the cherts are macroscopically white or red, and these types alternate in a systematic way to define major sedimentary rhythms. Other minor mesoband types also occur, but the only other common constituent of these iron formation members is stilpnomelane-rich shale. In the Joffre Member these shales are abundantly distributed in bands mostly less than 30 centimetres (1 ft) thick. In the Dales Gorge Member they are thicker and more regularly and widely spaced. In both members, the stilpnomelane of some bands within the shales clearly pseudomorphs volcanic shards or rock fragments. Ferristilpnomelane is characteristic of both the shales and iron formation of the Joffre Member, and ferrostilpnomelane similarly characterizes the Dales Gorge Member.

The distribution of stilpnomelane-rich shales in the lower 270 metres (820 ft) of the Joffre Member in a gorge south of Wittenoom has been recorded by Trendall (1969), together with the positions, at 113.4, 126.8, 131.7, 137.8 and 171.9 metres (372, 416, 432, 452 and 564 ft) above the base of the member, of five bands of "black porcelanite", respectively 36, 8, 61, 15 and 15 centimetres (14, 3, 24, 6 and 6 in) thick. Trendall (1969) referred to these as the first, second, third, fourth and fifth porcelanites, from the lowest upwards. These bands are perfectly concordant with the banding of the enclosing iron formation. In fresh gorge-bottom exposures the porcelanite is tough, almost homogeneous, and black to very dark green. It resembles bottle glass, and is almost as brittle, but has a flinty rather than a vitreous lustre. In cliff-edge exposures the ready weathering of the porcelanite, which is related to its high feldspar content, makes it stratigraphically conspicuous, but it has not yet been determined whether the described bands have a basin-wide extent.

The first porcelanite is divided by two thin partings rich in stilpnomelane into three sections, respectively 18, 8 and 10 centimetres (7, 3 and 4 in) thick from below upwards. The analyzed samples R2701, R2700 and R2699 were taken from these three divisions, respectively, at a point in the base of Joffre Gorge about 1.6 kilometres (1 mile) upstream of Oxers Lookout (Trendall, 1969, Plate 25). R2702 is from the third porcelanite, 0.4 kilometres (0.25 miles) farther upstream.

The sample (30527) of Joffre Member iron formation used is from a depth of approximately 152 metres (500 ft) in a drillhole (No. 47), 4 kilometres (2.6 miles) north of Oxers Lookout, at a stratigraphic level about 70 metres (230 ft) below the first porcelanite.

#### PETROGRAPHY OF THE PORCELANITE

Although the porcelanite appears almost homogeneous in hand specimen, thin bands of slightly paler colour are sometimes discernible, parallel with the stratification. These appear more plainly in thin section, where they can be seen to be defined by variations in proportions of the main minerals, rather than by major differences in mineralogy (Plate 19A).

Apart from this, and from minor textures to be described below, these rocks are as homogeneous and massive in thin section as their macroscopic appearance suggests; photographs of representative examples appear in Plates 19 and 20, and a brief general description which refers to these follows.

All examined samples have in common a mosaic of potassic feldspar of average grain diameter 4 to 20 $\mu$  which forms a continuous framework in which the remaining minerals are set, and which usually constitutes the bulk of the rock. Although it is too fine for the detailed structure of the mosaic to be optically resolved, the shapes of marginal grains against or within quartz in some samples (R2701) are discernible as sharply euhedral lozenges and rectangles about 10 $\mu$  in their long dimensions.

Within this main framework of feldspar there lie, in differing relationships to it, quartz, texturally distinct feldspar, one or more varieties of stilpnomelane, magnetite and riebeckite. The quartz is mainly in clear, unstrained, single individuals up to 0.1 mm across. The general shape is anhedral, sub-angular, to subhedral, and usually roughly equant. Such quartz grains are evenly distributed through any one band or thin section, but their abundance varies between different slides from about 0 to 10 per cent of the area. One quartz crystal was noted with enclosed rutile needles which terminated abruptly at the margins without change of thickness. Patches of fine quartz mosaic also occur within the feldspar mosaic. Scattered single crystals of slightly cloudy potassic feldspar, of about the same size and shape as the larger quartz grains, have a similarly scattered distribution but are much more scarce.

All rocks examined contain ferrostilpnomelane, pleochroic in shades of red-brown to brownish green, which is usually evenly distributed in poorly formed crystals and clusters up to about 0.05 mm across. It is quite striking that there is a wide range of crystal size, and little regularity in shape (Plate 20A). Some samples (R2702) have also abundant random flakes of pale green ferristilpnomelane up to 0.5 mm across but mainly less, and only about 0.001 mm thick. These are arranged in clusters which define, by enclosure, elongate patches of clear feldspar mosaic, about 0.1 mm long and elongate about 10:1. These are in places curved, and then resemble forms often interpreted as those of welded pumiceous debris, but their definition is too poor for confidence. Similar but larger shapes are defined by the dark ferrostilpnomelane of R2066.

Magnetite is usually evenly distributed through the rock in euhedral crystals mostly between 0.01 and 0.001 mm across, but in R2702 the magnetite is large, skeletal and ragged. Strings of small magnetites locally lie along the banding direction, and assist in the definition of band edges (Plate 20). Riebeckite usually occurs in small scattered prisms about 0.1 mm long, in various textural situations, but never forms a significant proportion of the rock. Spongy, rounded carbonates up to several millimetres across have a very irregular distribution. They may be absent or abundant and concentrated in bands. From refraction index observations they are probably dolomite, but may be ankerite; they have not been reliably identified.

A single small rounded grain of zircon, and several of possible epidote have also been noted.

#### EXPERIMENTAL PROCEDURE

##### *Sample Preparation*

About 100g of each sample were reduced to -100 mesh using a jaw crusher and a Kurt Resch hammer mill. After splitting, about 10g were further ground for about 15 minutes in a Kurt Resch automatic mortar grinder.

##### *Chemistry*

An accurately weighed sample of each rock selected for analysis was placed in a teflon dish. For a 0.5g sample approximately 10 mls of 48 per cent HF and 1.5 mls of 70 per cent HClO<sub>4</sub> were required for the dissolution, the mixture finally being taken to dryness on a hotplate. The residue

was then dissolved in 30 mls of 2.5N HCl and the solution taken to dryness. Approximately 10 mls of 2.5N HCl were then added and the solution transferred to a quartz ion exchange column containing 20g of wet Dowex 50W-X8, 200-400 mesh cation exchange resin. Strontium was eluted using 2.5N HCl, the cut being taken between 45 and 55 mls. The eluted sample was taken to dryness, redissolved in a minimum of 2.5N HCl, and placed on a micro column containing 1g of cation resin. The strontium was then eluted as before and the eluant taken to dryness ready for mass spectrometric analysis.

#### Mass Spectrometry

Isotopic analyses were carried out on a 12-inch radius, 90° magnetic sector, solid source mass spectrometer. The source and collector slits were set to 0.004 inches and 0.020 inches respectively to provide a resolution of approximately 400. The sample was mounted as the chloride on the side filament of a conventional triple filament surface ionization source. Rhenium filaments, which were outgassed prior to use, were employed throughout. No evidence of rubidium or strontium contamination from the filaments or ion source could be detected. New filament buttons were used for each sample and the source was cleaned between successive analyses.

The usual operating currents for strontium, loaded as the chloride, are 4.0 amps for the centre ionizing filament, and approximately 1.0 amps for the side filaments. For rubidium chloride, slightly lower currents were used. For a strontium analysis the filament currents were initially adjusted to a value where strontium emission was minimal. These conditions were retained for about 1 hour to enable the alkali beam, which was invariably present, to be reduced to a level where it no longer had a serious suppressing effect on the production of strontium ions. After the rubidium beam was reduced to a negligible size, the side filament temperature was gradually increased until an Sr<sup>88</sup> ion beam of the order of 10<sup>-12</sup> amps was obtained. For a 1 μg sample this beam could be maintained over several hours of operation without a marked decrease in intensity.

The mass range 84 to 88 was scanned on a sensitive scale during the analysis in order to detect the presence of any rubidium at mass 85. The isobaric contribution of Rb<sup>87</sup> to the Sr<sup>87</sup> ion beam was always less than 0.01 per cent.

An electron multiplier with a gain of about 10<sup>4</sup> was used as the ion detector. The resulting signals were amplified in a vibrating reed electrometer with a 10<sup>9</sup> ohm input resistor. A voltage to frequency converter, followed by an electronic counter allowed digital presentation of the data, which was fed on-line to a small digital computer. The amplifying system was periodically calibrated for scale factors, linearity and speed of response.

The isotopic peaks were scanned from the lowest mass to the highest mass and then back again, this operation constituting one sweep. Ten sweeps usually comprised a mass spectrometer "run". The sweep speed was adjusted so that at least five counts of 1 second each were recorded across the top of each peak, whilst a minimum of time was spent on the baseline between the peaks. The computer was programmed to select a number representative of the height of each peak immediately after sweeping through the peak. This information was then stored in memory until the mass spectrometer run was finished, after which a complete statistical analysis of the isotopic ratios was carried out. The final results could thus be presented at a teletype, situated in the mass spectrometer laboratory, within a minute of the end of run.

Replicate analyses of Eimer and Armend standard strontium carbonate were made over a period of time to give a mean value of Sr<sup>88</sup>/Sr<sup>86</sup> of 8.2800 rather than 8.3752 as determined by other authors (Faure and Hurley, 1963). The difference is largely due to the influence of electron multiplier-induced mass discrimination. After correcting the meas-

ured Sr<sup>88</sup>/Sr<sup>86</sup> ratio to 8.2800, the actual value found for the Eimer and Armend standard Sr<sup>87</sup>/Sr<sup>86</sup> ratio was 0.7080. The Sr<sup>87</sup>/Sr<sup>86</sup> ratios contained in Table 1 have likewise been normalized to Sr<sup>88</sup>/Sr<sup>86</sup> equal to 8.2800.

TABLE 1. RUBIDIUM-STRONTIUM ANALYTICAL DATA FOR SAMPLES FROM THE JOFFRE MEMBER

Sample	Rb/Sr	Rb <sup>87</sup> /Sr <sup>86</sup>	Sr <sup>87</sup> /Sr <sup>86</sup>
30527	2.11 ± 0.08 *2.14 ± 0.04		
Mean	2.13 ± 0.04	6.30 ± 0.13	0.9550 ± 0.0010
R2702 (HCl)	*2.51 ± 0.05	7.46 ± 0.15	1.0054 ± 0.0018
R2702	10.6 ± 0.4 *10.5 ± 0.2		
Mean	10.5 ± 0.2	33.0 ± 0.7	1.6235 ± 0.0017
R2702 (Residue)	*20.4 ± 0.4	69.0 ± 0.4	2.4670 ± 0.0035
R2701	21.1 ± 0.8	71.4 ± 2.9	2.4580 ± 0.0025
R2899	22.9 ± 0.9	78.8 ± 3.2	2.6736 ± 0.0028
R2700	28.4 ± 1.1	102.3 ± 4.1	3.2348 ± 0.0034

\* These values have been determined by isotope dilution; all the others in this column were determined by X-ray fluorescence

#### X-ray Fluorescence

This technique was used to select rocks with favourable Rb/Sr ratios for mass spectrometric analysis and also to determine precise values of the Rb/Sr ratio for the selected samples. A Siemen's SRS-1 fluorescence spectrometer equipped with a molybdenum tube, a lithium fluoride (200) crystal and a scintillation detector, was used for the Rb-Sr analyses. Finely ground samples (-200 mesh) were pressed with a boric acid backing and were then in a form suitable for X-ray fluorescence analysis.

Rubidium was read at a 2θ position of 26.56° and strontium at a 2θ position of 25.09°. Before selecting the background positions, consideration was given to possible interference effects, and the profile of the background in the vicinity of the RbK<sub>α</sub> and SrK<sub>α</sub> peaks was carefully observed, the most satisfactory background positions for this spectrometer were found to be at 2θ positions of 27.06° and 25.81° for rubidium and 25.59° and 24.59° for strontium.

A preset count of 2x10<sup>5</sup> was used for each position and a dead-time correction was then made. Each sample was measured a number of times depending on the concentrations of rubidium and strontium in the particular sample.

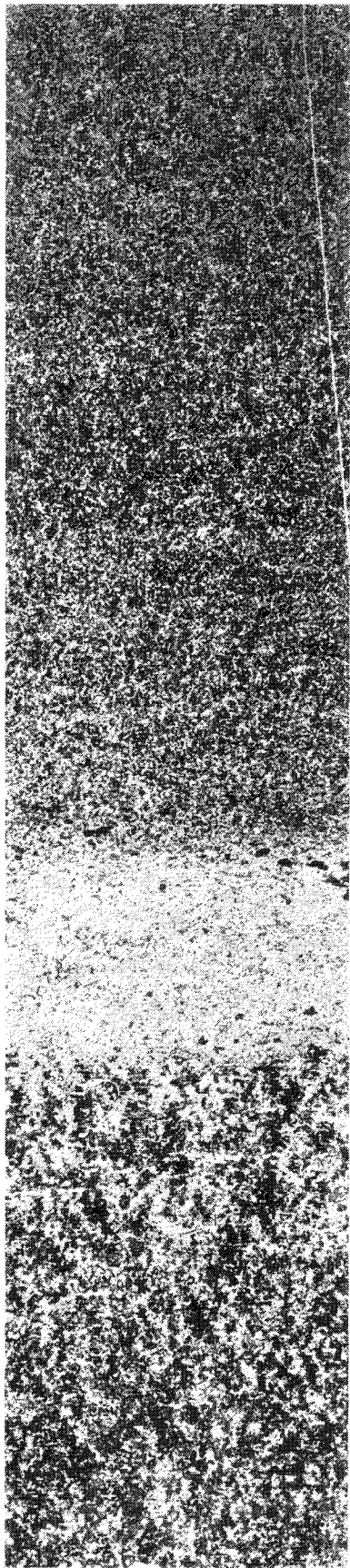
A factor was used to convert the raw Rb/Sr ratios to the true weight ratios. This conversion factor was determined by calibrating the spectrometer against a number of standard rocks of accurately known Rb/Sr ratios. The concentrations of rubidium and strontium in the standard rocks were determined by the stable isotope dilution technique (de Laeter and Abercrombie, 1970). The calibration of the spectrometer allowed for matrix effects and the variable fluorescent response between rubidium and strontium. Machine drift during an analysis was obviated by analyzing a reference sample between each run. In addition an appropriate standard rock was analyzed with each suite of samples.

#### Isotope Dilution

The Rb/Sr ratios of two of the samples listed in Table 1 were determined by isotope dilution as well as by X-ray fluorescence. This enables a minor adjustment to be made to the X-ray

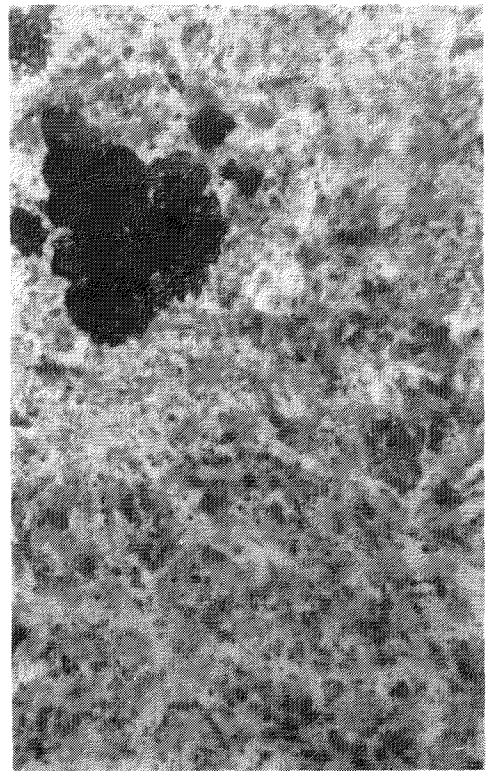
#### PLATE 19 (opposite)

- Macrograph of part of a thin section of the first porcelanite, approximately 20-24 cm from the base. The banding, clearly defined by variation in grain-size and proportions of quartz, feldspar and stilpnomelane, is not apparent in hand specimen. R2700: for location see text.
- Micrograph of material from the third porcelanite (R2702: see text). A subhedral carbonate crystal (upper left) lies in a matrix of fine-grained potassic feldspar and ferrostilpnomelane. The distribution of these two constituents vaguely defines elongate pale patches interpretable as shards.
- Micrograph of part of the lower band of A, showing thin flat "flakes", possibly shards, outlined by black ferrostilpnomelane and magnetite.



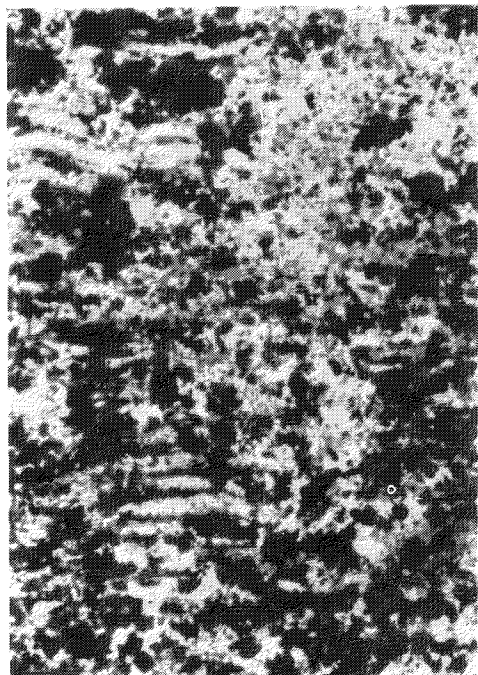
**A**

1 CM



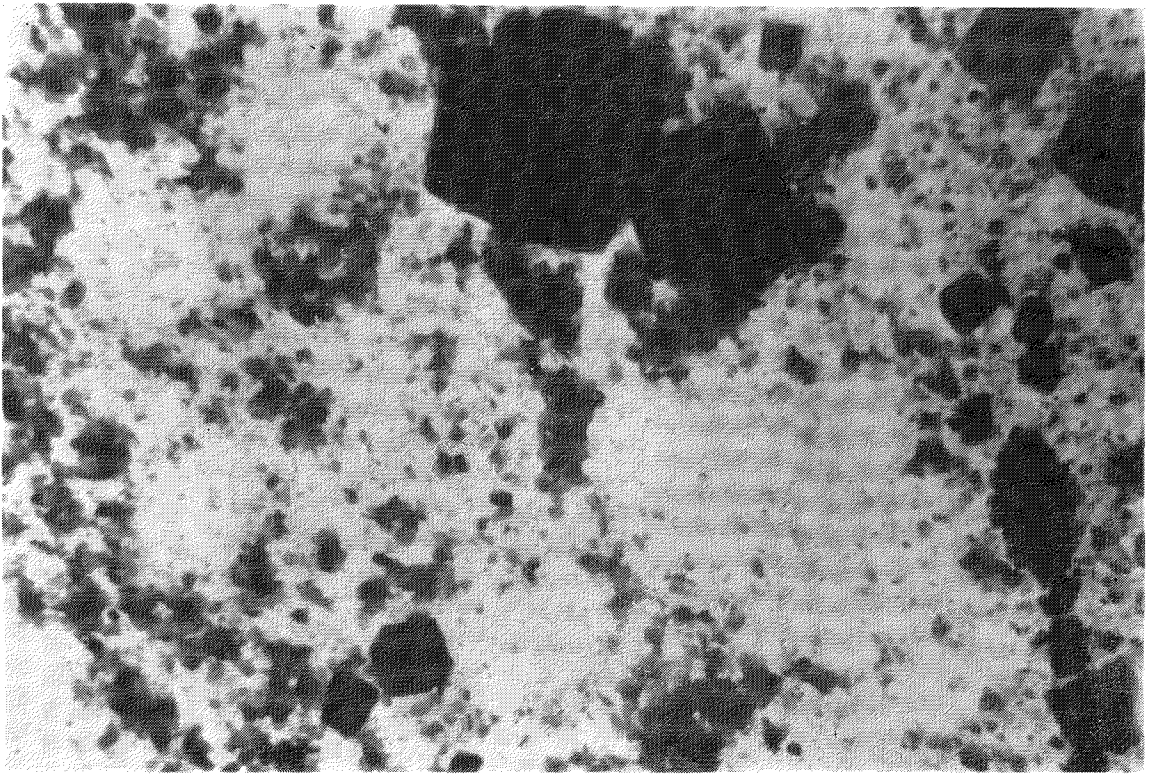
**B**

0.1 MM

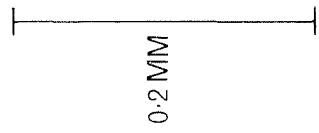


**C**

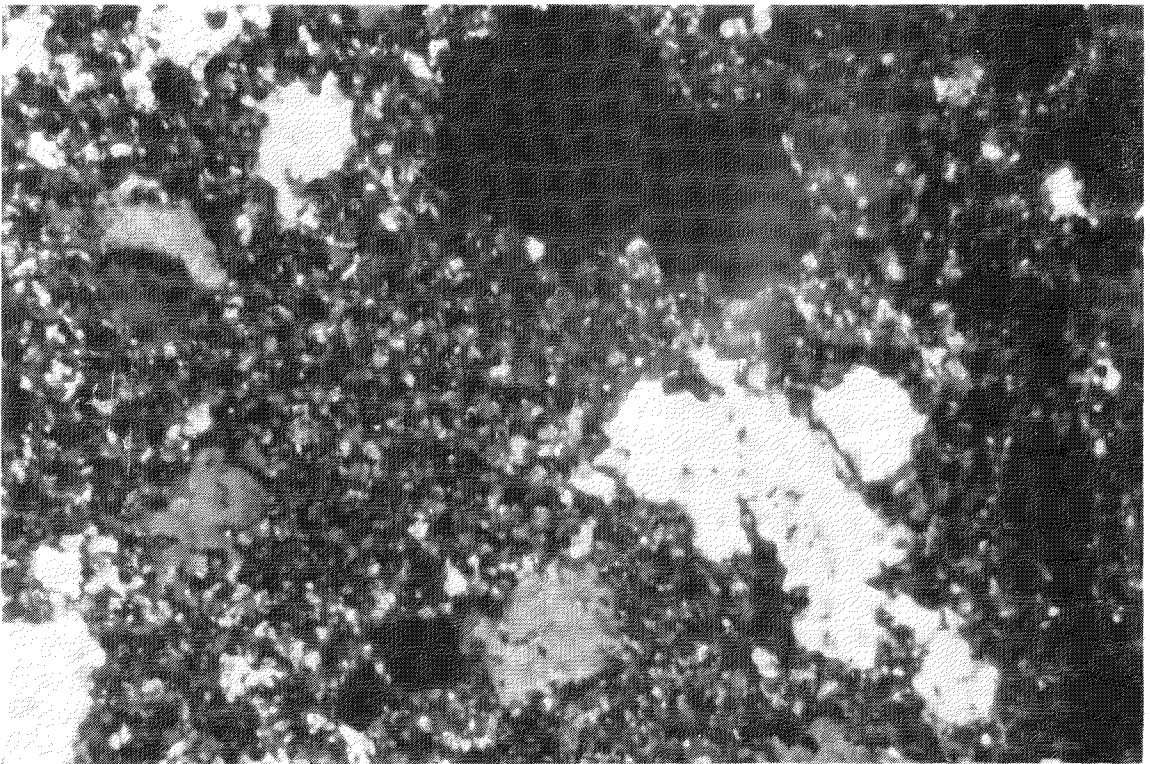
0.5 MM



**A**



**B**



fluorescence values if necessary, for differences in matrix between the standard rocks and the samples representing the Joffre Member. In the present project, however, the isotope dilution and X-ray results were identical to within experimental error. Two samples, R2702 (HCl) and R2702 (residue), were analyzed only by isotope dilution since the matrix in each of these two samples was completely different from the standard rocks which had been used to calibrate the X-ray spectrometer.

Weighed quantities of Rb<sup>87</sup> and Sr<sup>86</sup> spikes were added to the rock samples prior to dissolution. Each sample was dissolved as discussed above in a HF-HClO<sub>4</sub> mixture, and the rubidium and strontium separated by cation exchange chemistry. Blank determinations showed that the Rb and Sr contamination introduced by the chemical processing was less than 10<sup>-8</sup>g and 10<sup>-7</sup>g respectively. Full details of the isotope dilution technique used in this laboratory are given by De Laeter and Abercrombie (1970).

## RESULTS

The measured Rb/Sr and Sr<sup>87</sup>/Sr<sup>86</sup> ratios as well as the Rb<sup>87</sup>/Sr<sup>86</sup> ratios calculated from these, are given in Table 1 for each of the seven samples analyzed. The errors accompanying the ratios are

given at the 95 per cent confidence level. Five of the samples are whole rocks, but in addition, sample R2702 was allowed to stand in dilute hydrochloric acid for approximately 12 hours, and the solution then separated from the residue. The Sr<sup>87</sup>/Sr<sup>86</sup> and the Rb/Sr ratios of both solution and residue were determined and these values are also listed in Table 1. Sample R2702 contained some carbonate which dissolved fairly readily in the hydrochloric acid. Strontium was concentrated in the acid-soluble minerals and this portion gave a much smaller Rb/Sr ratio than in the whole rock sample. Conversely the insoluble residue was depleted in strontium, and gave a Rb/Sr ratio almost twice as large as the original Rb/Sr ratio of sample R2702.

All seven samples fell on an isochron which is plotted in Figure 27 to give an age of 1,720±25 m.y. and an initial Sr<sup>87</sup>/Sr<sup>86</sup> ratio (R<sub>i</sub>) of 0.8114±0.0037. The age and initial ratio were calculated using the method of Williamson (1968) which minimizes the weighted sum of the squared residuals. The age calculation is based on a Rb<sup>87</sup> decay constant of 1.39 x 10<sup>-11</sup> year<sup>-1</sup>. The errors associated with the age and initial ratio are calculated from the standard deviation of the slope and intercept respectively.

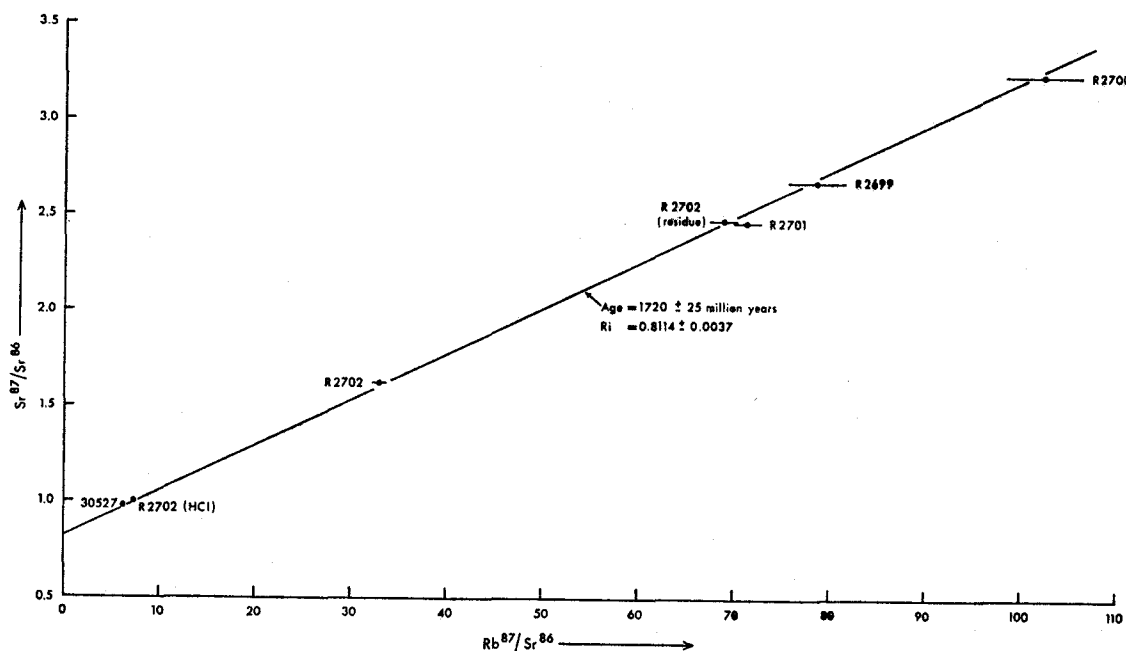


Figure 27. Isochron plots for the data of Table 1. The horizontal bars show the errors as given in that Table. Errors for Sr<sup>87</sup>/Sr<sup>86</sup> are within line thickness.

## DISCUSSION

### Origin of the black porcelanites

Before discussing the isotopic results it is necessary to establish the geological status of the black porcelanite. Trendall and Blockley (1970, p. 78) recorded the view that the black porcelanite may

represent tuff, without supporting discussion. They also, in discussing the origin of stilpnomelane bands in which shard pseudomorphs put a volcanic origin beyond doubt, wrote (p.290): "direct addition of airborne ash to the basin resulted in thin layers of glass shards which were probably replaced by stilpnomelane during or soon after their fall into the water". Stilpnomelane-rich shales and black porcelanites are visibly separate rocks within the iron formation, between which no intergradational types have been recognized: the further problem therefore arises, not discussed by Trendall and Blockley, of how basinal volcanicity gave rise to two petrographically distinct types of tuff within the iron formations.

In considering initially the problem of stilpnomelane tuffs there are three reasons why acid vol-

### PLATE 20 (opposite)

A and B are microphotographs in ordinary light and with crossed nicols, respectively, of the same area of the first porcelanite about 10 cm above its base. The main minerals present are ferristilpnomelane, potassic feldspar, quartz and magnetite. Magnetite appears black in both A and B. Ferristilpnomelane appears dark grey in A, but cannot be distinguished from the fine-grained feldspar mosaic in B. The larger quartz and feldspar crystals, which merge with the mosaic in A, stand out clearly in B. The string of small magnetites at the base of both photographs lies at the edge of a paler band, and helps to define the stratification. R2701: for location see text.

catic ejectamenta are to be preferred as the initial materials available. Firstly, acid glass tuffs are generally more abundant than those of basic or intermediate composition; secondly, acid volcanics form the Woongarra Volcanics, closely above the Joffre Member in the Hamersley Group; and thirdly, the relatively high potassium content of stilpnomelane argues strongly for a rhyolitic association. Four analyses of rhyolites from the Woongarra Volcanics, of which three have not previously been published, are given in Table 2 together with an analysis of a black porcelanite sample, referred to later in this discussion. The mean of the rhyolite analyses is given in column 1 of Table 3, recalculated as weight per cent of silicon and major metals to the nearest 1 per cent. This form has the advantages of showing ferric and ferrous iron together and of focussing attention on the materials presenting the principal bulk problems. In columns 2 and 3 of the same table analyses of ferrostilpnomelane and ferristilpnomelane, from the Dales Gorge Member and Joffre Member respectively, are shown in the same form. Although there is, between these two stilpnomelanes, a wide disparity in several chemical features which are commonly variable in Hamersley Group stilpnomelanes (for example, K/Al ratio), it is clear that over-riding these there is a major paucity of silicon and a similar abundance of iron in the stilpnomelanes, and also a disparity in magnesium. Column 4 of Table 3 shows column 1 recalculated to 100 per cent after addition of sufficient iron and magnesium by weight (79 and 14.5 parts respectively per 100 parts rhyolite cations) to bring the final contents of both metals to the mean of those of columns 2 and 3. This process, eminently credible in the iron-charged waters of the basin, brings the silica content close to that of stilpnomelane, and while aluminium is still high, the aluminium/potassium ratio is well within the wide limits of different stilpnomelanes. While not proof of the hypothesis, this chemical comparison does give it plausibility. It is worth noting that the implied access of magnesium into the rhyolitic glass, along with the more readily anticipated iron, may be related to the unexpectedly high magnesium content of many of the iron formation carbonates reported by Trendall and Blockley (1970, p. 118-121).

TABLE 2. TOTAL ANALYSES OF FOUR RHYOLITES FROM THE WOONGARRA VOLCANICS AND OF ONE BLACK PORCELANITE FROM THE JOFFRE MEMBER

	1	2	3	4	5
	R89	R207	R627	15624	R2701
SiO <sub>2</sub> .....	74.3	75.4	75.2	73.98	65.54
Al <sub>2</sub> O <sub>3</sub> .....	10.8	10.6	9.54	11.28	11.54
Fe <sub>2</sub> O <sub>3</sub> .....	0.69	0.66	0.87	0.73	4.22
FeO .....	3.19	2.93	3.17	2.42	4.58
MgO .....	1.10	0.64	1.17	0.60	1.20
CaO .....	n.d.	0.44	0.24	0.51	<0.01
Na <sub>2</sub> O .....	0.31	0.81	0.71	0.43	<0.01
K <sub>2</sub> O .....	7.59	6.19	6.28	8.02	11.43
Li <sub>2</sub> O .....	0.31	0.15	0.17	<0.01	n.d.
H <sub>2</sub> O <sup>+</sup> .....	1.65	1.46	1.82	1.07	0.91
H <sub>2</sub> O <sup>-</sup> .....	0.09	0.11	0.10	0.15	0.12
CO <sub>2</sub> .....	n.d.	n.d.	n.d.	0.24	0.21
TiO <sub>2</sub> .....	0.29	0.33	0.27	0.50	0.08
P <sub>2</sub> O <sub>5</sub> .....	n.d.	0.03	0.23	0.09	0.33
SO <sub>2</sub> .....	n.d.	0.10	0.03	n.d.	.....
MnO .....	0.04	0.03	0.04	0.02	<0.01
FeS <sub>2</sub> .....	.....	.....	.....	0.07	0.09
Total .....	100.36	99.88	99.84	100.11	100.25

n.d. = not determined

Analysts: 1. R. W. Lindsey; 2 and 3. M. B. Costello; 4 and 5. R. S. Pepper

1. Rhyolite, Boogeeda Creek (not previously published)
2. Rhyolite, Woongarra Pool (not previously published)
3. Rhyolite, Kalgan Creek (not previously published)
4. Rhyolite, Nallanarring Creek (Trendall, 1972, Table 1)
5. Black porcelanite, Joffre Gorge: for location see "Material used". (Analysis also appears in Trendall and Blockley, 1970, Table 16)

TABLE 3. COMPOSITIONS OF VARIOUS MATERIALS DISCUSSED, EXPRESSED AS WEIGHTS PER CENT OF SILICON AND MAJOR METALS

	1	2	3	4	5	6	7
Si .....	70	41	36	36	58	56	61
Al .....	11	5	2	6	11	18	11
Fe .....	6	41	47	44	12	.....	10
Mg .....	1	9	7	8	1	.....	1
Na .....	1	1	.....	(0.5)	.....	.....	.....
K .....	11	3	8	6	18	26	17

NOTE: Major metals in this table are defined as those exceeding 0.5 per cent as oxides in the full analysis. All the columns above are recalculated to 100 per cent and rounded to the nearest 1 per cent

1. Mean of four rhyolites from the Woongarra Volcanics (Table 2)
2. Ferrostilpnomelane, Dales Gorge Member (Trendall and Blockley, 1970, Table 16, 3)
3. Ferristilpnomelane, Joffre Member (Trendall and Blockley, 1970, Table 16, 4)
4. Column 1, recalculated to 100 per cent after addition of iron and magnesium to bring each of these to the mean of columns 2 and 3
5. Black porcelanite, Joffre Member, R 2701 (see column 4 of Table 1)
6. Theoretical KAlSi<sub>3</sub>O<sub>8</sub>
7. Recalculation to 100 per cent of an arbitrary mixture of column 3 (20 per cent), column 6 (60 per cent) and Si (20 per cent)

If this mechanism, reaction of rhyolitic glass with basin water to form stilpnomelane, is accepted as the "normal" depositional end product of basinal volcanicity, why are the black porcelanites, if they are tuffs, different? Although there is no direct evidence for their igneous derivation, of equal strength to the reliable shard pseudomorphs in some stilpnomelane bands, several points argue persuasively for their similar identity as tuffs. Firstly, from a total reconstruction of the basin environment (Trendall and Blockley, 1970, p. 278 on), the introduction of clastic material in thin confined bands within the Joffre Member by normal sedimentary means would be quite anomalous; the material is not likely to be a precipitate, and volcanicity is the most reasonable alternative purely as a transport mechanism. Secondly, the chemical composition is anomalous for that of normal shale. According to Pettijohn (1957, p. 369) "only about one shale in twenty has 5 or more per cent potash". Of the analyses of high-potash shales used by Pettijohn as examples of the group, the highest K<sub>2</sub>O content quoted, 10.85 per cent, belongs, in fact, to a feldspar concentrate rather than the total rock (Gruner and Thiel, 1937), and the highest total rock K<sub>2</sub>O quoted is 5.96 per cent. Clearly then, the black porcelanite is chemically unusual for a clastic sediment. Thirdly, the textural suggestions of volcanic fragments (Plate 19), and the compositional banding, conform with an igneous air-fall derivation.

Any suggested origin of the porcelanites must take into account, as a major feature to be explained, the abundance of potassic feldspar, and the consequent approach of the total chemical composition to this. In column 5 of Table 3 the composition of black porcelanite given in Table 2 is re-expressed in terms of major cations. In column 6 of Table 3 appears the theoretical cation weights of KAlSi<sub>3</sub>O<sub>8</sub>, while in column 7 a similar theoretical composition is shown of a material consisting of 20 per cent of column 3 (the "normal" volcanic end product of the Joffre Member), 60 per cent of column 6, and 20 per cent of silicon. Columns 5 and 7 then appear sufficiently similar to investigate whether this purely arbitrary mixture can be related to a realistic genetic model.

There are good grounds to interpret the larger quartz and feldspar grains (Plate 20) of the black porcelanite as volcanic crystal ejectamenta. Although clearly marginally affected by diagenesis, their variably angular shapes do not suggest authigenic growth under any consistent post-depositional stress field within the rock. The authigenic growth of relatively "giant" quartz grains within an otherwise fine-grained rock is not observed elsewhere in the Hamersley Group. Finally, such textural features as the termination of rutile needles noted in the description of petrography seem to give proof of primary individual origin to at least some of the grains.

It is therefore envisaged that the volcanicity which produced the black porcelanites differed markedly from that resulting in stilpnomelane in that, instead of producing only glass fragments, its products were a mixture of glass, potassic feldspar crystal debris, and quartz crystal debris, in the very approximate weight proportions 10 per cent, 60 per cent, and 20 per cent; the remaining 10 per cent of material was taken up from the basin water by the glass. On settling, much of the finer feldspar debris recrystallized into a fine mosaic, leaving the smaller content of quartz as the dominant presently visible primary material. Although the suggested weight proportions result from calculations on major cation compositions (Table 2) the accuracy of the estimate does not justify recalculation back to the slightly different total oxide weights, since the actual proportions evidently differed within wider limits: the banding of Plate 19A, which has been preserved through intense diagenesis, testifies to these fluctuations in glass/crystal proportions. The authigenic development of potassic feldspar in tuffs is known in relatively recent tuffs (Hay, 1966; Sheppard and Gude, 1968, 1969), but in these cases there has been a zeolite precursor.

The suggestion that the volcanicity which gave rise to the black porcelanites differed in character from the usual volcanicity of the basin is in accordance with their much greater thickness than any visibly shard-bearing stilpnomelane shale (1 to 5 centimetres: Trendall and Blockley, 1970, p. 114). The greater volume of crystal debris may be assumed to be correlated with eruptions of a larger order in terms of both violence and total volume.

#### Significance of the apparent age

It is apparent from Figure 27 that at 1,720 m.y. there was virtually perfect isotopic homogeneity not only between different mineral phases (acid-soluble and others) of R2702, but between all the porcelanites and their enclosing iron formation over a substantial stratigraphic thickness. The high initial  $Sr^{87}/Sr^{86}$  ratio immediately argues strongly against this as a depositional age, since this interpretation would require this initial ratio to be that of the basin water with which all the material equilibrated. Although the possibility of such an extreme value cannot be ruled out from available data in the at least partly confined waters of the Hamersley Basin (Trendall and Blockley, 1970), it is virtually certain that this could not have represented the ratio for oceanic water of the time (Peterman and others, 1970; M.I.T., 1965).

An additional argument comes from previous rubidium-strontium data from the Mount Bruce Supergroup, and from rocks intruding it. Although there is now a significant body of such data no part of the supergroup can yet be confidently assigned an age within narrow limits. However, in Table 4 all relevant published determinations are assembled in a vertical sequence which, on geological evidence not discussed in detail here, should be chronological. From this it can be seen that, apart from a minor anomaly derived from inadequate data within the Wyloo Group, all the ages except the 1,720 figure under present discussion are in chronological sequence within the quoted error limits. On these grounds also, then, its interpretation as a depositional age is not preferred, and it remains to discuss whether it has real significance, or whether it is an accidental result of various processes not related to any geological event at that time.

There are again two arguments for the geological reality of the 1,720 m.y. age. Firstly, as has been pointed out, Figure 27 testifies to isotopic homo-

geneity on a wide range of scales at that time: within a single 36-centimetre (14 in) thick porcelanite (R2699, R2700, R2701), between two porcelanites 18.3 metres (60 ft) apart, and between both these porcelanites and iron formation 70 metres (230 ft) farther below the lower porcelanite. This argues strongly for an abrupt termination in time of previously extreme isotopic mobility; any gradual decrease of mobility would surely result in a corresponding gradual decrease of the scale of isotopic homogenization, which would be reflected in the analytical results. Secondly, geological reality is supported by the concordance of the age with that of the Boolaloo Granodiorite, which intrudes the Wyloo Group (Table 4) some 240 kilometres (150 miles) west of the location of the material here discussed, and close to the likely western margin of the depositional basin.

TABLE 4. SUMMARY OF PUBLISHED RUBIDIUM-STRONTIUM GEOCHRONOLOGICAL RESULTS FROM ROCK UNITS FOR WHOSE TIME RELATIONSHIP TO THE JOFFRE MEMBER THERE IS GEOLOGICAL EVIDENCE

Rock unit	Quoted age (m.y.)	Type of determination	Authority
Granodiorite intruding Wyloo Group (Boolaloo Granodiorite)	1,720	Concordant isochron of total rock, biotite and feldspar	Leggo and others, 1965
Wyloo Group acid igneous rocks: flows or sills	2,020 ± 165	Total rock isochron; details not yet published	Compston and Arriens, 1968
Wyloo Group tuff	1,850 maximum	Single total rock	Leggo and others, 1965
Woongarra Volcanics	2,000 ± 100	46 total rock samples: 2 parallel isochrons; full data not yet published	Compston and Arriens, 1968
	about 2,100	Isochron of 4 total rocks	Leggo and others, 1965
Joffre Member	1,720 ± 25	See text	This paper
Lavas in upper part of Portescue Group	2,190 ± 100	Total rock isochron; details not yet published	Compston and Arriens, 1968
Granophyre intruding lower part of Portescue Group	2,196 ± 56	Isochron of 6 total rocks	De Laeter and Trendall, 1971

We therefore suggest that the apparent age of 1,720 ± 25 m.y. reported here marks a real period of regional geological activity which included both the intrusion of the Boolaloo Granodiorite and the termination of free isotope mobility within the Joffre Member. It is usual, when discussing the record, within a rock, of an age later than its origin, to refer to this as an up-dating due to a later event. In this instance it may be useful to consider a distinction between the reported age as an event, that is, as a relatively short-term imposition at that time of a new state of isotopic equilibrium replacing a former state which had remained stable since deposition, or simply as the termination of a condition of isotopic mobility which had never been otherwise. Once again, the excellent agreement of different sampling scales seems to argue here for a preference for the second alternative. The preferred hypothesis, by no means proven, is thus that the 1,720 m.y. "event" in the Joffre Member represents the time at which initial isostatic recovery of the depositional basin after the termination of Wyloo Group deposition led to an abrupt diminution of the pore fluids which, originating as entrapped basin water at the time of deposition, had subsequently remained in the rocks to facilitate extreme and continuing internal chemical mobility.

#### REFERENCES

- Compston, W., and Arriens, P. A., 1968, The Precambrian geochronology of Australia: *Canadian Jour. of Earth Sciences*, v. 5, p. 561-583.
- De Laeter, J. R., and Abercrombie, I. D., 1970, Mass spectrometric isotope dilution analyses of rubidium and strontium in standard rocks: *Earth and planetary sci. letters*, v. 9, p. 327-330.
- De Laeter, J. R., and Trendall, A. F., 1971, The age of the Gidley Granophyre: West. Australia Geol. Survey Ann. Rept. 1970, p. 62-67.
- Faure, A., and Hurley, P. M., 1963, The isotopic composition of strontium in oceanic and continental basalts: *Jour. Petrology*, v. 4, p. 31-50.
- Gruner, J. W., and Thiel, G. A., 1937, The occurrence of fine-grained authigenic feldspar in shales and silts: *Am. Mineralogist*, v. 22, p. 842-846.
- Hay, R. L., 1966, Zeolites and zeolitic reactions in sedimentary rocks: *Geol. Soc. America Spec. Paper* 85, 130p.
- Leggo, P. J., Compston, W., and Trendall, A. F., 1965, Radiometric ages of some Precambrian rocks from the Northwest Division of Western Australia: *Geol. Soc. Australia Jour.* v. 12, pt. 1, p. 53-65.
- Massachusetts Institute of Technology, 1965, Evidence from Western Ontario of the isotopic composition of strontium in Archaean seas: M.I.T., Dept. Geology and Geophysics, 13th Ann. Prog. Rept., p. 145-147.
- Peterman, Z. E., Hedge, C. E., and Tourtelot, H. A., 1970, Isotopic composition of strontium in sea water throughout Phanerozoic time: *Geochim. et Cosmochim. Acta*, v. 34, p. 105-120.
- Pettijohn, F. J., 1957, *Sedimentary rocks* (2nd edition): Harper and Bros., New York, 718p.
- Sheppard, R. A. and Gude, A. J., 1968, Distribution and genesis of authigenic silicate minerals in tuffs of Pleistocene Tecopa, Inyo County, California: U.S. Geol. Survey Prof. Paper 597, 38p.
- 1969, Diagenesis of tuffs in the Barstow Formation, Mud Hills, San Bernardino County, California: U.S. Geol. Survey Prof. Paper 634, 35p.
- Trendall, A. F., 1969, The Joffre Member in the gorges south of Wittenoom: West. Australia Geol. Survey Ann. Rept. 1968, p. 53-57.
- 1972, An unusual eutaxitic rock from the Precambrian Hamersley Group of Western Australia: West. Australia Geol. Survey Ann. Rept. 1971, p. 65.
- Trendall, A. F., and Blockley, J. G., 1970, The iron formations of the Precambrian Hamersley Group, Western Australia, with special reference to the associated crocidolite: West. Australia Geol. Survey Bull. 119, 366p.
- Williamson, J. H., 1968, Least squares fitting of a straight line: *Canadian Jour. of Physics* v.46, p. 1845.



# INDEX

	Page		Page
Babbagoola Beds	52	Meckering earthquake	31
Bassendean Sand	46	Muderong Shale	23
Bejah Claystone	54	Officer Volcanics	52
Birdrong Formation	23	Paterson Formation	54
Browne Beds	52	Petroleum—	
Cattamarra Coal Measures Member	45, 61	Barrow Island	43
Clutterbuck Beds	52	development and production	43
Cockleshell Gully Formation	61	drilling	39
Earthquake education	34	Dongara	44
Earthquake risk zoning	26	exploration	37
Edjudina meteorite	62	tenements	38
Eneabba Member	45, 61	Platinum, Rudall River area	59
Eutaxitic texture	65	Plumridge Beds	55
Gascoyne alluvium	24	Rocky Pool 'anticline'	25
Gearle Siltstone	24	Safety Bay Sand	46
Geology—		Samuel Formation	54
Eneabba area	61	South Perth Formation	61
Lort River area	58	Structural history, southern Perth Basin	46
Rudall River area	59	Sue Coal Measures	45
Gold, Rudall River area	59	Table Hill Volcanics	52
Hamersley Group	65	Toolonga Calcilutite	24
Heavy mineral deposits	61	Townsend Quartzite	51
Joffre Member	68	Underground water—	
Korojon Calcarenite	24	lower Gascoyne River	16
Kulyong Volcanics	52	north Gnangara	11
Lampe Beds	54	Yenart Soak	13
Lefroy Beds	51	Wanna Beds	53, 56
Lennis Sandstone	53	Windalia Radiolarite	24
Lort River Fault	58	Yardarino Sandstone	45
Lupton Beds	51	Yarragadee Formation	61
Maxicar Beds	45		

# DIVISION V

## Report of the Superintendent Surveys and Mapping for the Year 1971

*The Under Secretary for Mines,*

For the information of the Hon. Minister, I submit my report on the activities of the Surveys and Mapping Branch, for the year ended 31st December, 1971.

The anticipated increase in efficiency, due to the occupancy of Mineral House, helped greatly to deal with the work arising from the mining upsurge of 1970.

### STAFF

The membership of the staff, now totals 109 officers, comprising 92 males and 17 females in the following Divisions:—

Professional	....	....	34
Clerical	....	....	6
General	....	....	42
Technical	....	....	4
Cadet Cartographers	....	....	23

There were eight resignations during the year, in various categories of employees, but normal recruitment and advertisement throughout Australia and overseas resulted in the appointment of the following:—

- 6 Level 1 Cartographic Draftsmen
- 12 Drafting Assistants (male and female)
- 2 Clerical Officers
- 1 Technical Officer
- 6 Cartographic Cadet Draftsmen

Cartographer Mr. E. Beasley is still seconded to the Commonwealth Department of External Territories, and is attached to the Department of Public Service of Papua and New Guinea.

Cadet Cartographer Mr. D. Tomich and Drafting Assistant Mr. J. Devereaux, qualified in the Diploma of Cartography and were appointed to the Level 1, Career range as Cartographic Draftsmen.

Three cadets, Messrs. Loughton, Lofts and Kearns qualified, in the latter part of the year, and are eligible for appointment in the new year.

A total of 15,634 hours of overtime was worked, just exceeding that of the previous year.

An increase in the number of staff engaged in the Registration Section and the use of improved methods has had the result of transferring applications more quickly and in greater numbers to the Survey Section of the Branch where 63,383 unsurveyed and 4,868 unexamined mining tenements await processing.

Particular attention is being given to clearing this backlog of work and to reducing the deposited amount of survey fees held in the Treasury Suspense Account.

This Account totalled \$8,483,541 on the 31st December, 1970 and \$9,095,702 at December, 1971 despite survey fee refunds amounting to \$2,748,179 for the year.

Expenditure of \$541,445 during 1971 for surveys performed, was the highest in the history of the Department.

The number of Surveyors, authorised by the Hon. Minister to perform cadastral surveys for this Department, now stands at 75.

All dealings under the Petroleum legislation in both the "onshore" and "offshore" areas and under the Petroleum Pipelines Act, are being handled expeditiously and all maps show the up-to-date situation at any given time.

Itemised reports, of the activities of the three main sections of the Branch, are appended hereto.

A. A. HALL,  
Superintendent Surveys and Mapping.

### SURVEY SECTION

#### 1. SURVEYS

Survey of mining leases, claims, sections of temporary reserve boundaries and other tenements were carried out during the year by Licensed Surveyors by contract arrangements with the Department. Survey work done is summarised by the following tables.

Table A

Number of Surveyors	....	....	....	....	36
Number of survey parties used	....	....	....	....	45 parties
Number of tenements surveyed	....	....	....	....	4,129
Number of field books lodged	....	....	....	....	484
Total boundary line run	....	....	....	....	485,600 chains
Total traverse or connection line run	....	....	....	....	21,702 chains
Total acreage delineated by survey	....	....	....	....	907,871 acres
Total mileage travelled	....	....	....	....	42,773 miles
Total value of survey work	....	....	....	....	\$500,935.21
Total value of photogrammetric survey	....	....	....	....	\$40,509.98

Table B

Surveyor	Field books	Surveys	Acres
M. J. McKimmie	62	469	113,061
M. M. Fisher	29	*362	†72,820
K. J. Croghan	30	*326	†63,414
F. R. Rodda	22	254	69,896
G. Pascott	27	*235	†18,220
T. L. Markey	22	*226	†35,426
D. F. Wilson	14	*219	†29,770
D. J. Cox	21	210	56,932
A. G. Thompson	20	192	54,093
M. J. Byrne	32	*192	†31,185
R. J. Bennetti	17	172	48,156
W. A. Berryman	18	135	28,167
P. Blackadder	14	131	34,821
M. Milne	16	107	27,221
L. J. Burkett	12	100	18,877
R. A. Holland	12	*91	†18,489
J. A. Jamieson	21	89	26,736
G. A. Bateman	11	82	20,946
J. F. Weber	8	78	19,520
G. C. Callaghan	6	42	11,601
P. J. Hannebery	5	39	11,441
R. A. Hoskin	4	38	10,580
I. M. Gordon	9	36	10,424
J. Guidice	4	33	9,272
K. J. Amsuss	5	31	9,040
S. B. Montgomery	4	29	7,505
J. V. Keating	3	28	7,253
W. Lenz	3	27	7,159
M. R. McMullen	5	26	5,532
A. C. Watson	2	25	7,160
H. W. Denton	6	25	4,207
P. J. Hille	3	24	6,044
L. G. Privett	5	22	4,576
W. A. Johnson	3	18	4,895
J. R. Greville	1	13	2,263
E. Brook	1	2	P561
G. McShane	1	T.R.	.....
K. J. Lyons	1	T.R.	.....
W. G. Cotterill	1	T.R.	P.....
G. F. Hamm	4	T.R.	P.....
	484	4,129	907,871

\* Includes some surveys measured photogrammetrically.

† Excludes some acreage in a photogrammetric survey.

P Private negotiation.

These figures show an increase of 71 per cent. in the value of the surveys completed in the field when compared with 1970. This has been largely achieved by the extra time spent in the field by the Surveyors on Mines Department work compared with time spent a few years ago. Whilst 36 surveyors are shown as submitting work to the Department, this figure can be increased to 45 effective survey parties due to amalgamations in some organizations and others submitting field work through one nominated chief surveyor.

Nineteen new surveyors were introduced to the work for the first time during the year, whilst 9 surveyors, who did work during 1970, did not operate during 1971.

The large amount of survey work completed can be attributed to the urgent requirement by many claim holders for the protection and correct positioning of their tenements afforded by survey and the availability of more surveyors. Applicants have been encouraged to nominate to the Department those claims that need priority of survey including those that have some potential mineral occurrence. In fact many companies will not commence exploration or cannot obtain listing on some Stock Exchanges until their tenements are surveyed. With the large number of claims pegged, it is recognized that some of them have been taken up for rapid evaluation prior to a decision being made concerning their retention for further exploration or for their relinquishment. It is considered that the policy of selective survey has been largely successful, with the result that there is now a large number of surveys completed. These are surveys which will be of lasting value, forming as they do, a suitable framework for future control for mapping purposes.

Naturally with such a large volume of work originating from the fields, difficulties are being experienced in integrating the results of the surveys into the office

systems. This was recognized at the beginning of the year and the option existing under the Survey Regulations which allows the Department to draw the diagrams at cost was withdrawn and surveyors are now requested to submit their field notes accompanied by drawn diagrams. This freed a large proportion of the work force for work on examination and associated processes.

All cases of special request were able to be satisfied and no serious cases of disputed survey arose during the year.

In most cases of Temporary Reserve definition requiring recourse to geographical co-ordinates, it has been possible to originate them from adjacent geodetic values. However in two instances no geodetic values were available and astro-fixes were used. It is now possible to correct for deflection of the vertical in astronomical observations and these corrections were applied so that the fixes are technically sound.

During the year a further photogrammetric survey was commenced. The area was considered as a photogrammetric prospect following a request for an official survey to delineate the principal mineral holding held by the Western Mining Corporation under the terms of the Nickel Refinery (Western Mining Corporation) Agreement Act. This is an area of about 256 square miles negotiated by Western Mining with the Government for the development of the extensive nickel laterite deposits in association with the establishment of a smelter at Kalgoorlie. The area is also extremely prospective for the occurrence of nickel sulphide ore bodies and will be prospected for many years to come. Also included in the area of this photogrammetric project are approximately 1,000 mineral claims held by some 100 different interests. Many warden's court decisions are pending awaiting survey and the pegging situation in the area is complicated. At the end of the year all photography had been completed and the photographs were being prepared for machine co-ordinates.

This project is of great interest and has the most far reaching potential of anything of this nature yet undertaken in this State. Two more such projects are planned for 1972.

## 2. GEODETIC

Further work was carried out on survey co-ordinates in the A.M.G. system. Although limited staff could be allocated to this work, 280 miles of line were traversed in the Ora Banda-Broad Arrow-Kunanalling areas in connection with the photogrammetric survey and 143 miles in the Leinster Downs area. A demand for this type of co-ordination exists in many other areas of the State where Mining Companies, and others, require precise values in a National system. It is not possible to satisfy this demand at present due to limited staff.

## 3. PETROLEUM

During the year the first Production Licences were granted under the Petroleum Act 1967. These were granted to W.A.P.E.T. on the 25th October, 1971 as follows:—

P/L 1—5 Blocks at Mondarra

P/L 2—4 Blocks at Dongara

P/L 3—5 Blocks at Walyering

In addition Pipeline Licence No. 1, which was granted on 2/12/70, was brought into operation and two further Pipeline Licences in connection with this project were granted during 1971.

Important discoveries of gas were made on Permits in the onshore and offshore areas, namely on EP 24 at Walyering, WA-33-P at Scott Reef, WA-1-P at North Rankin and WA-28-P at Bonaparte Gulf.

No work towards the completion of the plans in the million series was done during the year as staff was fully committed to survey activities in the Section. Gridded plans on a blank base are in use, as an interim measure, for those plans not yet finalized.

#### 4. CONCLUSION

During the year 5,713 hours of overtime were worked in the Section. This, together with the record amount of field work completed has indicated a successful year, and it now remains for these results to be properly integrated on the plans and into the Department's records in a manner which will be of lasting benefit both to the Department and the mining industry.

#### MAPPING SECTION

The two areas of Mapping continued and demands for new plans at 1 : 50,000 scale were still high.

The programme of Geological Mapping increased, particularly the 1 : 250,000 series.

#### STANDARD MAPPING

A total of 197 new 1 : 50,000 maps were produced each requiring an original, a working transparency for taking prints and 2 mounted prints edged and coloured to be used as Public Plans at Head Office and respective outstations.

A programme of revision was also commenced to upgrade some plans in areas that were rushed during the "Boom" period. The change in control data and sheet corner values due to the A.M.G. grid in some areas presented join problems and rectification had to be done. A total of 32 plans were revised.

New areas that were covered with 1 : 50,000 maps either in part or whole were:—

Port Hedland	Robertson	Dixon Range
Bedout Island	Newman	Gordon Downs
Dampier	Onslow	Cambridge Gulf
Yarrie	Ningaloo	

A new programme of 1 : 100,000 scale maps was commenced in Eastern areas and maps were produced covering Minigwal, Plumridge, Noonkanbah.

#### GEOLOGICAL MAPPING

##### 1 : 50,000 Maps

Four sheets covering the geology of the Metropolitan area were printed by the Government Printer.

##### 1 : 250,000 Maps

The main programme of mapping continued and the following sheets were completed and sent for printing.

Menzies	Kurnalpi
Peak Hill	Jubilee
Balladonia	Forrest
Zanthus	

Work proceeded on Cue and Esperance and new sheets to be commenced were:—

Norseman	Moora (pt. only)
Murgoo	Perenjori (pt. only)
Malcolm-Cape Arid	Edjudina
Perth (pt. only)	Dongara-Hill River
Pinjarra (pt. only)	Vernon

The Geraldton sheet was prepared for drawing to be done by contract. This was let through the Bureau of Mineral Resources to a firm in Canberra.

#### State Map

All drawing work was completed and checked. Screen masters for printing plates to be made later.

#### Bulletins

Bulletin work continued, with No. 122 of the Eucla Basin being printed.

Bulletin 121 of the Blackstone area was completed with 3 colour plates.

Mineral Resources Bulletin No. 9 covering lead deposits of W.A. was completed.

#### Technical Plans

During the year 225 miscellaneous plans and diagrams were drawn for the Geological Survey of W.A.

#### Photography and Plan Printing

##### Plan Printing:—

The number of prints of plans decreased to 41,056 of which 10,385 were for Geological Survey. Plans requiring mounting numbered 1,485 and 2,915 plans were photo-copied, making a total of 45,456 items processed in this section.

##### Photography:—

This year saw an increase in the variety of photo work being done in this section.

98 Metal A.B. Dick plates were prepared

42 Peelcote negatives at 40 in. x 30 in. size

4 "Wipe-on-dye" colour proofs 40 in. x 30 in.

105 photographic colour prints including 7 at 40 in. x 30 in. size

271 35 mm slides both colour and black and white were prepared

53 rolls of film both colour and black and white were developed

55 plates 6½ x 4½ were developed

1,915 photographic prints of various sizes from 6½ x 4½ were made

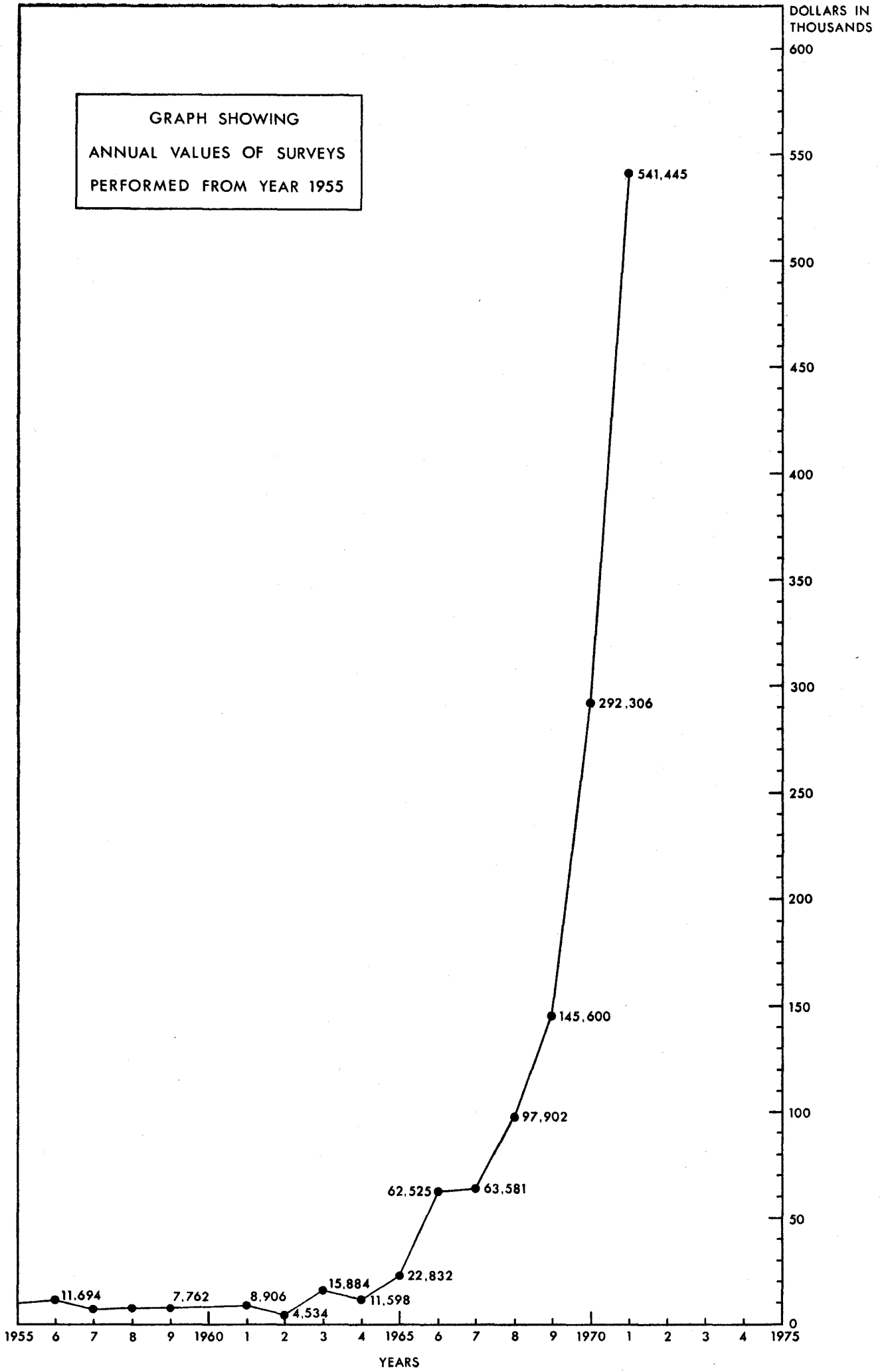
1,459 items of process work on the vacuum frames from sizes 8 in. x 10 in. up to 36 in. x 45 in. were prepared

1,530 items of photographic work were prepared on the process camera including reductions, enlargements, and same size copy.

#### General

During the year 2 displays were prepared for "Careers weeks" programmes, one at Fremantle and one at Midland Junction.

GRAPH SHOWING  
ANNUAL VALUES OF SURVEYS  
PERFORMED FROM YEAR 1955



### PUBLIC PLAN SECTION

During the year of 1971, 31,398 applications were received in the section comprising:—

MCs	27,106
PAs	452
GMLs	163
Dredging Claims	343
M.L.s	209
QAs	53
CMLs	725
MHL, LTTs, TLs, GA, BA, WR, MYLs, RAs, WL, RL, MYL	67
Total	29,118

A backlog of 14,089 applications to be charted was carried over from 1970.

The backlog at the end of 1971 was 1,935 applications which indicates 41,272 applications were chartered.

The backlog in Temporary Reserve processing was overtaken.

Nine thousand six hundred and seventy-five searches of the Land Titles Office were made reducing the backlog to nil.

Head Office Plan sales totalled \$11,819.21 from the sale of the following:—

Dyelines	12,202
Ozalid Transparencies	240
Electrostat Photo copies	4,821
Iron TR List	123
Other Minerals TR List	110
State Map	553
Min. Occurrence Map	314
Gazetteer	515

Backlog of appraisal checking has been reduced to acceptable numbers. Many Public Plans require checking for cadastral tenure and replacement.

A start has been made on complete State coverage of minimum 1 : 250,000 scale.

# DIVISION VI

## CONTENTS

Administration—	Page
Committees .....	129
Staff .....	129
General, Samples and Operations in 1971 .....	130
Summarized Reports of Divisions—	
Agriculture .....	131
Engineering Chemistry .....	138
Foods, Drugs, Toxicology and Industrial Hygiene .....	142
Industrial Chemistry .....	146
Kalgoorlie Metallurgical Laboratory .....	150
Mineral, Mineral Technology and Geo-chemistry .....	150
Water .....	158
Tables showing Source and Nature of Samples received in 1971—	
General, Table 1 .....	131
Agriculture Division, Table 2 .....	132
Foods, Drugs, Toxicology and Industrial Hygiene Division, Table 14 .....	142
Mineral, Mineral Technology and Geo-chemistry Division, Table 21 .....	150
Water Division, Table 22 .....	158

## DIVISION VI

# Government Chemical Laboratories Annual Report—1971

### *Under Secretary for Mines:*

I have the honour to present to the Hon. Minister for Mines a summarised Annual Report on the operations of the Government Chemical Laboratories for the year ended 31 December, 1971.

### *Administration*

Early in 1969 the Kalgoorlie School of Mines was transferred from the Department of Mines to the Western Australian Institute of Technology. However the associated Kalgoorlie Metallurgical Laboratory was not so transferred but remained in the Department of Mines under the direct control of the Under Secretary. For some years the future of the Laboratory was in doubt, whether it should be disbanded or should be continued either along the same lines as previously or under a different charter. The Department of Mines engaged an outside consultant to investigate the future of the Kalgoorlie Metallurgical Laboratory and as a result of his report it was decided to continue the operations of the Laboratory and to transfer it to the Government Chemical Laboratories.

This decision was made effective late in 1971. The Deputy Director and the Chief of the Engineering Chemistry Division visited the Kalgoorlie Metallurgical Laboratory to assess the present position and to recommend future action. For the present the Laboratory will be continued along the same lines as in the past, as a seventh Division of the Government Chemical Laboratories.

This situation is a close parallel of mid 1960 when the Bureau of Research and Development in the Department of Industrial Development was transferred to the Government Chemical Laboratories. Now, as then, we received a group that had been relatively neglected for some time and as a result was very short of staff. Now, as then, the first requirement was to re-vitalise the group, bring staff numbers up to strength and plan ahead. This is particularly so for the Kalgoorlie Metallurgical Laboratory for the land on which it is situated will be required by the Western Australian Institute of Technology in the not too distant future for expansion of buildings of the Institute. A start has been made with this programme of restoration and increase.

The Government Chemical Laboratories therefore now consist of 7 Divisions, a Library and a central office all under the control of the Director (Government Mineralogist, Analyst and Chemist) as follows:

Director—L. W. Samuel, B.Sc.Ph.D., M.A.I.A.S., M.R.S.H., M. Inst.F., F.R.A.C.I. F.R.I.C.

Deputy Director—R. C. Gorman, B.Sc., M.A.I.A.S., A.R.A.C.I.

Agriculture Division—H. C. Hughes, B.Sc., A.R.A.C.I., Chief of Division.

Engineering Chemistry Division—B. A. Goodheart, B.Sc., A.M.I.E.Aust., A.R.A.C.I., Chief of Division.

Foods, Drugs, Toxicology & Industrial Hygiene Division—N. R. Houghton, B.Sc., A.R.A.C.I., Chief of Division.

Industrial Chemistry Division—E. B. J. Smith, B.Sc., D.Phil., M.A.I.A.S., A.R.I.C., A.R.A.C.I., A.P.I.A., Chief of Division.

Kalgoorlie Metallurgical Laboratory—G. H. Muskett, A.W.A.S.M., A.M. Aust.I.M.M., Officer in Charge.

Mineral, Mineral Technology & Geochemistry Division—G. H. Payne, M.Sc., A.W.A.S.M., A.R.A.C.I., Chief of Division.

Water Division—N. Platell, B.Sc., A.R.A.C.I., Chief of Division.

Librarian—Vacant.

Office—D. E. Henderson, Senior Clerk.

The close association of these Laboratories with other Government Departments and kindred associations was maintained during 1971 and various members of the staff are members of the following Committees.

Commonwealth Scientific and Industrial Research Organisation, State Committee.

Fluoridation of Public Water Supplies Advisory Committee.

Food and Drugs Advisory Committee.

Laboratory Safety Committee.

Oils Committee of the Government Tender Board.

Paints Advisory Committee of the Government Tender Board.

Pesticides Registration Committee.

Pesticides Residues Advisory Committee.

Poisons Advisory Committee.

Rivers and Waters Technical Advisory Committee.

Scientific Advisory Committee under the Clean Air Act.

Swan River Conservation Board.

Veterinary Medicines Advisory Committee.

Water Purity Advisory Committee.



In addition the Director is a member of a Committee dealing with the disposal of the effluent from the Laporte Titanium works and the Deputy Director was a member of the Committee considering an Act to replace the Feeding Stuffs Act and the Veterinary Medicines Act, and a member of the Western Australian Institute of Technology Advisory Committee on Applied Chemistry.

Most of these Committees are very active and meet regularly and occupy considerable time of the officers concerned, not only for meetings, but also for inspections, preparation of information and analyses of samples.

The Pesticides Registration Committee dealt with 212 applications for registration of new pesticide formulations. The total number of applications considered by this Committee to 31st December 1971 is 2,656. A matter of great concern to this Committee is the poisonous nature of many of the newer pesticides, especially as many of them can be absorbed through the skin. The Committee has maintained its past policy of on occasions refusing registration of a pesticide as being too hazardous to health; placing an upper limit on the concentration of the active ingredient in the formulation to be distributed; or has restricted distribution to commercial pest exterminators. For the Swan River Conservation Board we analysed 177 samples of river water and 18 samples of effluents. The Veterinary Medicines Advisory Committee dealt with 1,098 applications, being 871 renewals, 152 new registrations, 34 changes of formula or claim, 9 deferred, 25 not required to be registered and 7 rejected.

#### Staff

During the year finality was reached on the appointment of a new Chief of the Engineering Chemistry Division, Mr. B. A. Goodheart being promoted to Chief of the Division.

At 31st December 1971 the establishment of the Laboratories was 130 being:

Professional	.....	74
General	.....	41
Clerical	.....	12
Wages	.....	3

1971 again proved a difficult year for staff, though not as difficult as 1968 and 1969; not as pre-1968 the difficulty of obtaining sufficient suitable staff, but in the number of changes of staff during the year. Staff changes, staff "turnover", in 1971 was less than in 1968 and 1969 but still much in excess of pre-1968. Apart from the time involved in such changes, they are unsettling and interrupt the free flow of work. Reduced output occurs also from the need to train new staff, even at the level of typists because of the not-usual nature of our language and reports. A major adverse effect of this staff turnover is that we are understaffed for so long because of the length of time required to obtain new staff.

The problems and difficulties of the year, including the financial restrictions and the reduced recruiting of staff, resulted in us losing ground in our service to other Government Departments and the public. At 31 December 1971 we had 3,833 samples on hand compared with 2,908 at 31 December 1970.

#### Library

Additions to the Library in 1971 totalled 3,243 items. This total included 373 monographs, 2,143 periodicals (separate items), 494 reports (separate items). During the year 14 new periodical titles were added to the Library, making a total of 276 periodicals now being received.

Loans to outside borrowers were 262. We requested 408 items from other libraries.

Items catalogued and indexed were 3,977.

#### Equipment

Major items of equipment purchased during the year included a gas-liquid chromatograph for the determination of amino-acids and fatty acids, an ultra-violet-visible spectrophotometer, a Davis tube magnetic test unit and a rotating cone concentrator.

#### Buildings

During the year the re-building of the former Fuel Technology Division building was completed and the Water Division transferred to it. This relieved the congestion in the Agriculture Division wing. Modifications were made to the building housing the rotary kiln at the Engineering Chemistry Division.

#### General

The number of registrations for 1971 was 5,204 compared with 5,223 for 1970 and the number of samples received was also slightly lower, 19,887 for 1971 compared with 20,666 in 1970.

The source of the samples received and their allocation to the various Divisions are shown in Table 1. In a number of cases sample(s) were allocated to more than one Division because for the full elucidation of the problem it was necessary to call on the ability and experience of different specialists. Such samples are not usually registered twice but do show in the totals of samples received by the Divisions so the total in Table 1 is greater than the total of samples quoted earlier in this report. This co-operation between and mutual assistance of Divisions helps to foster the policy that we are one Government Chemical Laboratories not 7 separate Divisions. Discussion and interchange of ideas between Divisions is encouraged since the problems received by one Division may be helped by, indeed may rely on, the specialist in another Division.

As a result of publicity for the treatment of cancer patients with an aqueous extract of the native shrub *Scaevola spinescens* these Laboratories continued the field collection of the shrub and the preparation and supply of the extract. When we previously did this, 1967-69, supply was through the Public Health Department but now we are supplying direct, having first obtained the written concurrence and approval of the patient's medical adviser.

The Director continued his duties under the Traffic Act including the alterations effected in the Regulations early in 1971.

The number of registrations and of samples does give some measure of our activities but does not completely describe our work. A major factor in this is the variation in the amount of work associated with different samples. Also it is not possible to give a statistical account of the time and effort devoted to the various Committees mentioned; to advisory work for Government Departments, industrial firms and the general public; attendance at Courts; visits to factories and so on.

Fees were charged for work undertaken for some State Government Departments, Government Instrumentalities, Commonwealth Government Departments, Hospitals, Milk Board, private firms and the general public, but the greater part of our work is done without charge for other State Government Departments.

The summarised reports of the individual Divisions which follow show the very wide range of subjects dealt with by these Laboratories. Comparing 1971 with 1970 there were some marked

Table 1  
Source and allocation of samples received during 1971.

Source/Department	Division						Total
	Agriculture	Engineering Chemistry	Food and Drug	Industrial Chemistry	Mineralogy	Water	
<b>State—</b>							
Agriculture Department	5,939	12	985		15	60	7,011
Child Welfare Department			1				1
Environmental Protection Department					1		1
Fisheries and Fauna Department	123		374			22	519
Forests Department			1		1		1
Harbour and Light Department			1				1
Hospitals	2		105			1	108
Industrial Development Department			1	2	7	5	15
Labour Department			52	1		1	54
Local Government Department					4		4
Main Roads Department	2		2	8	22	8	42
Medical Department			1			14	15
Mental Health Services Department			5	3			8
Metropolitan Water Board	4		2		11	2,231	2,248
Milk Board			178				178
Mines Department	3	62	48	79	756	516	1,464
National Parks Board						3	3
Native Welfare Department		1			57	3	61
Police Department	5		2,391		75		2,471
Public Health Department	4	7	798		572	32	1,413
Public Service Board				1			1
Public Works Department	2	1	64	42	19	1,725	1,853
State Electricity Commission					1		1
State Housing Commission				1			1
Swan River Conservation Board			87		1	108	196
Treasury Department			115	40			155
University of Western Australia			12				12
W.A. Fire Brigade Board			1				1
W.A. Government Railways			3				3
Zoological Gardens Board						1	1
<b>Commonwealth—</b>							
Army Department						1	1
Civil Aviation Department			1				1
Health Department			2				2
Navy Department					3		3
Postmaster General's Department					1	5	6
Repatriation Department			2			2	4
Royal Australian Air Force						3	3
Works Department					4	2	6
<b>Public—</b>							
Free					16	4	20
Pay	160	67	587	29	833	623	2,304
<b>TOTAL</b>	<b>6,244</b>	<b>150</b>	<b>5,818</b>	<b>206</b>	<b>2,399</b>	<b>5,875</b>	<b>20,192</b>

alterations in the numbers of various types of samples received. These were:—

Marked decrease	1970	1971
Animal specimens (Agriculture)	1,222	844
Fertilisers (other than Act samples)	359	86
Nickel ores	426	111
Soils	1,485	804
Vines	359	84

Marked increase	1970	1971
Drugs	65	111
Dusts	404	571
Feeding Stuffs Act	55	162
Fertiliser Act	143	262
Pasture	689	1,074
Pesticides	129	202
Rape seed and plant	n.s.r.	226

n.s.r. not sufficient for separate recording.

These changes show some interesting variations; in the Department of Agriculture a swing away from animal tissue analysis, soils and vines to samples under the Feeding Stuffs and Fertilisers Acts and a revival of interest in the rape plant; the public has shown a marked decline in interest in the glamour metal, nickel; an increase in concern over pollution as indicated by samples of dust and for pesticide residues.

So far as Government Departments are concerned the outstanding change in the number of samples received was from the Department of Fisheries and Fauna, an increase from 47 in 1970 to 519 in 1971. This increase was almost entirely due to concern on the effect of pesticides on wild-life. Not so marked increases, though still appreciable, were from the Police Department, from 2092 samples in 1970 to 2471 in 1971; the Public Health Department from 1027 in 1970 to 1413 in 1971. Much of this last increase was due to the large number of food samples, especially of fish, submitted for the determination of mercury following reports from overseas of excessive concentrations of mercury in fish.

There was a marked decrease in the number of samples submitted by the general public for which a charge was made, from 3144 in 1970 to 2304 in 1971.

L. W. SAMUEL,  
Director.

## AGRICULTURE DIVISION

### Introduction

During April the Water Division was able to move to their refurbished offices and laboratories. While amicable working arrangements had been maintained during the 17 months since that Division's formation, the space vacated was put to use to enable smoother functioning of this Division. The main features of the rearrangement were—

- (1) the Assistant Chief was able to move into his office.
- (2) in the laboratory thus vacated we built a flameless atomic absorption apparatus for the determination of mercury;
- (3) another small laboratory was used to house the gas chromatograph and its ancillary equipment, and the officer primarily responsible for its operation;
- (4) a room became available to house a set of equipment for the specific use of those engaged at any one time in the analyses of samples under the Fertilisers and Feeding Stuffs Acts;
- (5) the balance room vacated by the Water Division is now used for the Act samples and reagent preparation and also houses the electronic calculator.

The promotion of Mr. Z. E. Spadek from Technician to Chemist and Research Officer and the appointment in his place of Mr. Elton-Bott were the only staff changes.

### Equipment

A small electronic calculator with limited programming capacity and paper tape readout proved a boon for the calculating and checking of results.

The gas chromatograph obtained primarily for the determination of amino-acids was installed but is as yet only partly operable. It has been used for the determination of fatty acids mentioned later in this report.

The other major instrument received was a U.V.-visible spectrophotometer to replace that transferred to Water Division. The new instrument has the additional facilities of auto-sampler and recorder.

### Professional

A paper entitled "The Determination of Sub-Microgram Amounts of Cobalt in Plant and Animal Tissue by Extraction and Atomic-absorption Spectroscopy" by J. Jago, P. E. Wilson and B. Lee was published in the Analyst in May.

Mr. Jago continued as vice-President of the W.A. Branch of the Australian Soil Science Society and attended the Australasian Spectroscopy Conference in Melbourne.

Mr. Hughes continued on the program and joined the membership sub-committees of the W.A. Branch, Royal Australian Chemical Institute.

A program of talks was carried through at monthly intervals; 6 members of the staff spoke of the specific tasks to which they had been assigned and 3 officers of the Department of Agriculture visited us to expound on aspects of their work to which results from this Division had been applied.

#### Topics covered were—

- (1) Amino-acids.
- (2) The Grape Vine Nutrient Survey.
- (3) X-Ray Fluorescence of Agricultural Materials.
- (4) Fluorine, Its Estimation and Role in Air Pollution.
- (5) The Frustrations of Biological Trials.
- (6) Aspects of Trace Element Nutrition.
- (7) The R. A. C. I. Analytical Symposium.
- (8) Developing a Computer Program for Spectrometric Analyses.
- (9) Highlights of the 1971 Spectroscopy Conference.

### Analytical Methods

A brief outline of the 3 major developments of methods during the year is

1. Fatty Acids.—The gas chromatograph was used to determine the fatty acid composition of the oils extracted from rapeseed and other oil seeds. The method involves the extraction of the glycerides, their hydrolysis and the preparation of the methyl esters by refluxing with boron tri-fluoride/methanol. Solutions of the esters are processed on the Packard 7401 with flame-ionisation detectors. 6 ft x 4 mm coiled glass column, liquid phase 10 per cent. ethylene glycol adipate on A. W. Chromosorb W 80-100 mesh using inlet temperature 250°C, detector temperature 250°C, oven temperature 220°C and carrier gas flow rate 42 ml min.<sup>-1</sup>

Using the principle of equi-molar response the areas of the peaks corresponding to the individual acids are used to quantify the recorded trace.

It was found that commercial mixed fatty acid standards were not according to specification and standard mixtures prepared from individual standard acids were required. Standard mixtures and recoveries are carried through the procedure with each batch of reagents or new column.

2. Fluorine.—The use of the fluoride ion selective electrode offered apparent advantages over colorimetric procedures all of which, for plant materials, soils, etc., required previous distillation. However much work was necessary before a satisfactory method applicable in outline to both plant materials and soils was perfected.

Three primary problems had to be overcome—

- (i) ensuring that during ignition or fusion no fluorine was volatilised and lost;

- (ii) ensuring that fluorine was released from the mineral complexes in soil;

- (iii) avoiding or correcting for the effects of other ions which do affect the electrode.

The procedure adopted involves ignition of the sample with sodium carbonate-zinc oxide at 600°C, solution of the melt, reading with sodium citrate-potassium nitrate buffer, and if fluorine is very low in the sample, adding standard amounts of fluoride to the solution to give readings on the potentiometer having greater precision.

3. Mercury.—A method using flameless atomic-absorption was developed. A 15 cm flow cell was constructed having U.V. transparent end windows. The peak absorption by mercury vapour released after reduction with stannous chloride from aliquots of refluxed digests is read. Peak absorption calibrates with standard mercury solutions. Matrix effects from the varied material analysed are compensated by running concurrent recoveries of mercury added to equal aliquots of the individual digests. It was found necessary to free the sulphuric acid—stannous chloride solution used from hydrogen sulphide formed on admixture of those reagents.

Table 2  
Agriculture Division

	Agriculture Department	Fisheries and Fauna Department	Pay Public	Other Government Departments	Other	Total
<b>Animal—</b>						
Animal tissue .....	138	.....	.....	.....	.....	138
Bone .....	67	.....	.....	.....	.....	67
Faeces .....	56	.....	.....	.....	.....	56
Liver .....	389	.....	.....	.....	.....	389
Plasma .....	31	.....	.....	.....	.....	31
Rumen fluids .....	.....	123	.....	.....	.....	123
Urine .....	26	.....	.....	.....	.....	26
Wool .....	11	.....	.....	.....	.....	11
Various .....	3	.....	.....	.....	.....	3
Sub-total .....	721	123	.....	.....	.....	844
<b>Cereal—</b>						
Barley .....	6	.....	6	.....	.....	12
Wheat .....	58	.....	7	.....	.....	65
Various .....	.....	.....	6	.....	.....	6
Sub-total .....	64	.....	19	.....	.....	83
<b>Fertiliser—</b>						
Fertiliser act .....	262	.....	.....	.....	.....	262
Various .....	63	.....	22	1	.....	86
Sub-total .....	325	.....	22	1	.....	348
<b>Horticulture—</b>						
Apples .....	123	.....	.....	.....	.....	123
Apple leaves .....	493	.....	.....	.....	.....	493
Apple tree parts .....	300	.....	.....	.....	.....	300
Citrus leaves .....	35	.....	2	.....	.....	37
Grape vine parts .....	84	.....	.....	.....	.....	84
Leaves .....	23	.....	.....	.....	.....	23
Orange leaves .....	79	.....	.....	.....	.....	79
Peppermint tree parts .....	19	.....	.....	.....	.....	19
Plant material .....	167	.....	.....	.....	.....	167
Rapeseed plants .....	60	.....	.....	.....	.....	60
Rock melon parts .....	10	.....	12	.....	.....	22
Various .....	68	.....	.....	.....	.....	68
Sub-total .....	1,461	.....	14	.....	.....	1,475
<b>Miscellaneous—</b>						
Various .....	3	.....	5	5	1	14
Sub-total .....	3	.....	5	5	1	14
<b>Pasture and Fodder—</b>						
Clover .....	953	.....	.....	.....	.....	953
Feeding stuffs .....	77	.....	29	.....	.....	106
Feeding Stuffs Act .....	162	.....	.....	.....	.....	162
Hay .....	.....	.....	10	.....	.....	10
Lucerne .....	82	.....	1	.....	.....	83
Lupin seed .....	123	.....	3	.....	.....	126
Meat meal .....	.....	.....	5	.....	8	13
Pasture .....	1,068	.....	6	.....	.....	1,074
Rapeseed .....	108	.....	4	.....	.....	112
Various .....	29	.....	5	1	2	37
Sub-total .....	2,602	.....	63	1	10	2,676
<b>Soil—</b>						
Soil .....	763	.....	28	13	.....	804
Sub-total .....	763	.....	28	13	.....	804
<b>TOTAL .....</b>	<b>5,939</b>	<b>123</b>	<b>151</b>	<b>20</b>	<b>11</b>	<b>6,244</b>

### Animal Nutrition

Diagnostic and nutritional work with stock continued at much the same level as last year. The change in emphasis from selenium to greater interest in cobalt is reflected in the very great increase in receipt of liver samples rather than kidney. This meant also that the method for determining cobalt by atomic-absorption mentioned in Professional proved most useful.

We took part with the C.S.I.R.O. Division of Biochemistry and the Animal Division of the Western Australian Department of Agriculture in a collaborative study of both cobalt and selenium in animal tissues and feeds in anticipation of joint experimental work at Esperance.

(a) The physical nature of a set of liver samples testing the trace element status of sheep from a stocking rate versus superphosphate treatment at Mt. Barker necessitated fat extraction before further sampling. The extracted fat of representative samples was analysed for cobalt, copper, iron, manganese, molybdenum and zinc to test the significance, if any, of the amount of element extracted together with the fat when calculated to the content of the whole sample. Only in the case of zinc was there a significant loss by fat extraction, losses of from 9 to 18 per cent of the total zinc content being involved, the total liver containing of the order of 100 parts per million dry basis.

(b) There were many more samples of porcine tissue received than in past years reflecting the widespread efforts of diversification into pig growing. The intensive nature of pig raising has its own inherent problems and skeletal malformations are among these. Samples of bone for calcium, phosphorus and fluorine contents were received from many sources.

(c) It was reported that levels for iron, selenium and zinc in the livers of young calves were not well documented. Six such samples from stock of varied origin slaughtered at Midland Abattoir gave the following results:—

Table 3

Sample	Trace Elements in Calf Liver		
	Iron, Fe	Selenium, Se dry basis parts per million	Zinc, Zn
1	170	0.42	160
2	170	0.33	140
3	150	0.34	150
4	130	0.43	310
5	140	1.2	120
6	170	0.33	160

(d) Unusual samples were the 150 samples of stomach contents of kangaroos and sheep on which crude fibre and protein were determined. These results formed part of a study by the Agricultural Protection Board of competitive grazing by the two animals.

### Cereals

There is an increasing interest in taking a closer look at the nutritional value of protein, including that in grain crops. Primarily because of this the gas chromatograph mentioned earlier was purchased. In the interim until this instrument becomes fully operative, work proceeded by manual methods, on the cereal grains from low and high rainfall areas, and with crops of high and low protein content from each. These were covered by 3 varieties of barley, 2 of wheat and one only of oats (groats).

For both barley and wheat and for all varieties the proportion of cystine in the protein was highest for crops grown at the Salmon Gums site, a low rainfall area where grain is high in protein. The

other sulphur containing amino-acid methionine did not show this consistent pattern. There were also appreciable variations in available lysine content, the tendency being for all grains to contain a higher proportion of lysine the lower the protein content.

These very preliminary results indicate that when it is possible to handle greatly increased numbers, variation in amino-acid composition may well be found to relate to a number of environmental factors, and at some future time segregation for nutritional purposes may follow segregation for manufacturing purposes.

1. Wheat.—Because some wheat with high protein content was being received separately by the marketing authority a number of farmers asked for the protein content of this grain. The interest was not only in sales in the present year but to compare varieties and preserve the better grain for seed for the next season.

Work with trace elements and wheat was centred in the Newdegate, Lake Grace area from where samples in connection with molybdenum and copper experiments were received. Of particular interest amongst these were results showing suppression of molybdenum levels by high rates of sulphate of ammonia due to the dilution effect of improved yields by the use of nitrogen fertiliser.

2. Barley.—Barley samples were confined more to its use as a stock food for cattle in particular. Should the efforts of the group interested in producing industrial alcohol from grain succeed there may be more work resulting from increased interest in barley which was chosen in preference to wheat for this process.

3. Oats.—The Grain Pool of W.A. were interested to be armed with all information which would aid them in making sales. We provided them with an analysis (Table 4) of W.A. No. 1 Standard Oats listing the parameters used in assessing feeding stuff value.

Table 4

Composition, W.A. No. 1 Standard Oats 1971

	per cent.
Moisture	11.1
Ash	2.5
Crude protein (N x 6.25)	7.9
Crude fat	9.0
Crude fibre	10.4
Nitrogen free extract	59.1
Calcium, Ca	0.06
Phosphorus, P	0.23
Kernel content	73.2
	calories per gram
Calorific value	4150

### Pastures, Fodders and Stock Foods

1. Feeding Stuffs Act.—(a) At 162 samples almost three times as many stock foods were submitted for analysis under this Act as in the previous year. 145 samples were reported including 13 carried forward from 1970, and of these 6 were of samples not registered.

Of the balance of 139 samples 100 through either deficiencies or excesses failed to comply with the registered analyses supplied. Approximately one quarter of these non-complying samples had deficiencies in protein and/or excesses of phosphoric acid and/or fat.

(b) Because of possible harmful effects and the need to comply with standards for carcass meat, Regulation 9 under the Feeding Stuffs Act prohibits the use in stock food of seed or grain which has been treated with mercurial compounds or selected organo-chlorine pesticides.

To find existing levels and to test whether any of these were to be found in stock food, samples submitted during 1971 were and are being tested for mercury by this Division and for organo-chlorine residues by the Food and Drug Division.

The finding of most significance was the relatively high level of mercury in whale products, both whale meal and whale solubles.

There is not as yet an agreed international standard for mercury in human food or stock foods, but considering that experience is that concentration may take place in the edible portion of animals and in eggs it is reasonable that at worst the diet of stock destined for human consumption should not contain more than the tentative limits set for human food. It is fortunate that the high mercury results are to be found in supplements or concentrates which would be diluted in feed mixes consumed by stock.

The finding of significant levels of mercury in whale products is not related to the prohibition on feeding treated grain, and neither were the listed organo-chlorine pesticide residues found at levels suggesting contamination by treated grain. However one sample was found to contain the unlisted pesticide aldrin at a level of possible significance in terms of food standards but this probably resulted from its meat meal content rather than from grain.

2. Clover.—(a) 17 samples from a glasshouse experiment tested the relative uptakes of phosphorus and sulphur from superphosphate of various granule sizes and by comparison with aerophos and/or gypsum in powder form, under leaching conditions.

Providing the superphosphate was at least 1 mm in diameter, uptake of phosphorus was at a maximum at about 0.25 per cent. compared with untreated samples at 0.19 per cent. The more mobile sulphur continued to give increases with increasing granule size up to the maximum screen size which was the fraction in excess of 4.8 mm. Nil sulphur material contained 0.21 per cent. and that with the large granules was 0.34 per cent. sulphur. This finding was in conflict with the equivalent rate of gypsum which was very much higher again at 0.42 per cent.

(b) A trial of the residual effects of rates of copper as copper sulphate and of zinc as zinc oxide at Wannamal yielded clover deficient in zinc without treatment. Treatment with copper produced the anticipated interaction, suppressing levels even further. Copper levels were critical and also suppressed by zinc treatment.

At least 5 lb per acre of copper sulphate and 1.5 lb of zinc oxide were required to have been used at seeding to maintain adequate levels of copper and zinc in the spring cuts of clover 6 years later.

(c) Many other samples of clover were for diagnostic purposes in the sense of nutrition of stock, and one particular experiment commenced in 1971 was a comparison of various clover cultivars. In addition to the nutrient elements nitrogen, phos-

phorus, sulphur, cobalt, copper, iron, manganese, molybdenum, selenium and zinc, material from these was analysed for acid detergent lignin and acid detergent fibre, two factors believed to be chemical determinations yielding close correlations with digestibility.

3. Miscellaneous pastures.—(a) A survey of mixed pastures for copper in the Margaret River, Bunbury, Busselton and Gingin districts was extended to cover iron, manganese and zinc. The district averages and ranges are given in Table 5.

(b) Pastures treated with residues containing nickel in 1969, were again sampled in October 71 and residual effects were still seen with levels of nickel up to 2 parts per million dry basis.

(c) Other work from the animal feed point of view included oaten hay which when conditioned gave a product lower in protein but higher in carbohydrate due to the more rapid drying, and samples of silage, hay and clover from problem properties where cattle in particular fail to develop or introduced stock suffer from wasting disease. These types of sample involve a wide range of analyses since the problem is not usually one of a simple deficiency but an imbalance of elements is possible.

4. Miscellaneous feeding stuffs.—(a) Prepared feeds for intensive farming were received ranging from feedlot experiments at Kununurra to pig, turkey, poultry and chicken feeds from both commercial and experimental sources. Laboratory animals were also covered with feeds for both guinea pigs and mice.

(b) The dust produced by electro-static precipitators on flue stacks is a very fine material of very low bulk density and of little or no industrial use.

One possible use for the material from lime production would be as a source of calcium for poultry. However a sample was found to have a very strongly alkaline reaction at pH 12.6 and to contain 50 per cent calcium hydroxide.

This material could not be fed straight but various mixtures are to be tested by feeding trials by the Poultry Branch of the Department of Agriculture.

(c) 3 pelleted feeds made of poultry manure, deep litter and a mixture of deep litter and wheat grain gave the analyses shown in Table 6.

Fowls excrete much of their nitrogen as uric acid which can be utilised by ruminants but not by monogastrics.

These pellets were to be used in feeding experiment with cattle and pigs so that distribution of nitrogen between protein and non-protein nitrogen, and of non-protein nitrogen between uric acid and other forms was required. Deep litter has been used successfully as a component of drought feed for sheep in particular

Table 5.

PASTURE TRACE ELEMENTS

District	Copper, Cu		Iron, Fe		Manganese, Mn		Zinc, Zn	
	Parts per million—dry basis							
	Average	Range	Average	Range	Average	Range	Average	Range
Margaret River	11.6	(4.3-16)	153	(80-410)	95	(36-260)	38	(18-180)
Bunbury	11.0	(4.4-16)	135	(70-420)	132	(34-760)	38	(19-99)
Busselton	11.2	(3.9-15)	129	(51-350)	149	(32-430)	56	(18-180)
Gingin	11.1	(3.8-16)	228	(88-1,200)	64	(31-140)	43	(25-130)

Table 6

	Poultry Manure (100%)	Deep Litter (100%)	Wheat + Deep Litter (55 + 35 parts by weight)
	per cent. as received		
Moisture	9.6	8.6	11.1
Ash	22.4	33.4	14.1
Fibre ash	11.3	26.3	8.9
Crude protein (N x 6.25)	26.5	15.6	12.8
Crude fat	1.4	0.6	1.2
Crude fibre	11.8	11.8	6.4
Nitrogen free extractive	28.3	30.0	54.4
Calcium, Ca	2.88	2.32	0.96
Phosphorus, P	1.46	0.95	0.57
Protein nitrogen, N	2.87	1.95	1.54
Uric acid C <sub>2</sub> O <sub>3</sub> (NH) <sub>2</sub>	6.2	0.48	0.27

5. Native species.—In order to obtain a better knowledge of the feeding value of some native shrubs grazed by sheep in the Carnarvon area the analyses shown in Table 7 were obtained.

The exceptionally high ash led us to carry out a number of analyses for components such as sodium and potassium not ordinarily found at these concentrations.

Table 7  
NATIVE SHRUBS

	Kochia polypterygia		
	1	2	3
	per cent dry basis		
Ash	28.8	30.4	27.6
Fibre ash	0.9	3.3	2.5
Crude protein (N x 6.25)	19.0	18.8	17.1
Crude fat	1.4	1.2	1.2
Crude fibre	13.1	12.6	15.0
Nitrogen free extractives	37.7	37.0	39.1
Calcium, Ca	2.11	1.00	1.76
Magnesium, Mg	0.49	0.31	0.46
Potassium, K	1.45	1.20	1.43
Sodium, Na	7.00	8.34	6.41
Chloride, Cl	6.7	5.3	5.2
Phosphorus, P	0.14	0.14	0.12
Sulphur, S	0.33	0.28	0.27

	Scaevola spinescens	Rhagodia Spp	Rhagodia gaudichaudiana
	per cent dry basis		
Ash	10.1	25.1	29.2
Fibre ash	0.5	1.2	1.3
Crude protein (N x 6.25)	12.9	24.1	12.7
Crude fat	1.8	1.2	2.3
Crude fibre	10.7	9.6	15.4
Nitrogen free extractives	64.5	40.0	38.1
Calcium, Ca	1.75	2.47	0.99
Magnesium, Mg	0.38	1.46	0.99
Potassium, K	2.19	7.06	10.9
Sodium, Na	0.64	1.25	2.18
Chloride, Cl	1.6	2.5	8.0
Phosphorus, P	0.14	0.19	0.31
Sulphur, S	0.59	0.36	0.32

Other plants are of value as pastures on salt affected land previously reported as valuable; among these is puccinellia. A sample taken at Bokal in February had a composition close to that previously recorded for this time of year. Another plant of potential value is Threlkeldia diffusa, previously recorded from Rottneest, but being propagated at Katanning. A sample taken in November had the composition given in Table 8 which includes oxalate, a possible hazard with this plant.

Table 8  
Threlkeldia diffusa

	per cent as received
Moisture	12.1
	dry basis
Ash	38.2
Crude protein (N x 6.25)	9.0
Crude fat	2.5
Crude fibre	13.0
Nitrogen free extractives	37.3
Calcium, Ca	0.94
Sodium, Na	10.2
Chloride, Cl	18.6
Oxalate, C <sub>2</sub> O <sub>4</sub>	1.78
Phosphorus, P	0.34

## Horticulture

1. Apples.—(a) Monthly samples of leaves were taken from each of 16 trees from spurs and shoots from November 1970 to May 1971, covering the two major varieties Jonathan and Granny Smith. The variations for each of the nutrients and for both tissues unless otherwise mentioned were:

Nitrogen fell throughout, the sharpest decline being during January, and the rate diminishing from then on.

Phosphorus fell rapidly in November-December with little subsequent variation.

Potassium reached a maximum in December in shoot leaves but after declining again in January showed only a slight further drop throughout.

Calcium rose steadily throughout the season.

Magnesium showed a 'hump' in concentration in December-January and then declined to a fairly stable level.

Sulphur varied only within very narrow limits.

Copper remained fairly stable from November to January and following a very sharp fall to February-March declined further in April-May.

Manganese levels remained fairly constant throughout.

Zinc rose to a maximum in January and then declined to a fairly constant level.

Conclusion to be drawn from these results from the point of view of diagnosis of deficiencies from nutrient concentrations are

- (i) the time of sampling is important particularly for nitrogen, calcium, magnesium, copper and zinc.
- (ii) February, after the major alterations in concentration, is the preferable month for sampling.
- (iii) if sampling must be done at another time allowance for the variations shown must be made.
- (iv) the extent and timing of the variations should be confirmed in order to allow confident extrapolation of results from various times of sampling.

Some other conclusions can also be drawn

- (i) nitrogen and phosphorus levels differ little between varieties and tissue, at least before March.
- (ii) shoots contain more potassium than spurs and Jonathan more than Granny Smiths.
- (iii) spurs contain much more calcium than shoots but there is no varietal difference.
- (iv) spurs contain much more magnesium than shoots except in November and the "hump" effect is more marked.
- (v) the variation in copper concentration is slightly more marked with Jonathan than Granny Smith but at the February-March period there is little tissue or varietal difference.
- (vi) spurs contain much more manganese than shoots and the difference is of the same order—about 15 to 20 parts per million—as the difference between the higher level in Granny Smith and the level found in Jonathans. This is consistent with Granny Smiths being more susceptible to manganese deficiency.
- (vii) spurs contain more zinc than shoots, Jonathan more than Granny Smith and shoot leaves of the latter are generally 5 parts per million below the spurs.
- (viii) spur leaves are the preferred single tissue for testing for the listed nutrients.

(b) There were a number of fertiliser experiments both in the South-west and the Darling Ranges.

The use of NPK fertiliser in spring, summer or autumn at Donnybrook showed little benefit by increasing the rate beyond 10 lb per tree in spring or autumn, and that summer fertilising was least advisable.

From a fertiliser and soil management trial at Stoneville leaves achieved the highest calcium content by the use of sulphate of ammonia and superphosphate at the rates equivalent to 2 lb of

nitrogen and 2 lb of phosphoric anhydride per tree. The use of an equivalent amount of potassium fertiliser in addition inhibited the uptake of calcium, which in view of the role of calcium in controlling scald and bitter pit implies that more than minimal amounts of potassium are contra-indicated.

(c) The results of many previous analyses of apple shoot leaves have now been used by the officers of the Department of Agriculture to establish ranges considered optimum and levels considered as showing deficiency for the elements nitrogen, phosphorus, potassium, calcium, magnesium, copper, manganese and zinc. These are still to be considered as tentative but reveal some considerable variation from levels applied elsewhere. They are also subject to the considerations of paragraph (a) of this section above.

The very many samples forwarded from various properties in the Manjimup-Bridgetown-Donnybrook districts bore witness to the continuation of this work and the application of the results to particular problems.

2. Citrus.—(a) A fertiliser trial on orange trees at Capel tested two rates of nitrogen, 1 or 2 lb of ammonium sulphate, the same of potassium sulphate and 10 lb per tree of superphosphate per year. Superimposed on this, two of the four replications also received 50 lb of lime per tree. Leaves from these trees showed—

- (i) nitrogen improved by nitrogen fertiliser only;
- (ii) potassium content doubled by the 2 lb per tree per year treatment, slightly suppressed by the superphosphate but not by the lime;
- (iii) calcium suppressed by potassium treatment but enhanced more by the superphosphate than by the lime;
- (iv) phosphorus and chloride unaffected by any treatment.

(b) 19 citrus leaves from the Wiluna Groundwater Research Station had been reported as evincing symptoms of zinc deficiency. However when analysed they were found to have between 130 and 460 parts per million of zinc in the dry matter—suggesting either that spraying had been carried out before sampling or that the symptoms of excess zinc resemble those of deficiency.

(c) 16 samples from a fertiliser treatment on a rootstock variety trial at Carnarvon served to emphasise the importance of the high level of boron and salt in the irrigation water. All samples contained in excess of 200 parts per million dry basis of boron, which is a high level and more than half contained more than 300 parts per million which is excessive. Chloride was high in 10 of the 16 and excessive in 4 others.

Phosphorus was satisfactory throughout, as was potassium which showed uptake from the fertiliser. Copper also improved with treatment, untreated leaves being at low or deficient levels.

3. Rock melons (cantaloupes).—Samples of rock melon plants grown commercially at Wiluna were received over a period of weeks in an endeavour to relate the use of nitrogen fertiliser to the severe wilting and death of plants following the lifting of plastic sheeting under which the seeds germinate and are left to grow for a limited time.

Total nitrogen in the whole leaves was at what would be judged as extremely high levels for other plants, 4.5 to 5.5 per cent. Since an American standard suggested that whole leaf nitrate-nitrogen should be at least 5000 parts per million, and petiole 7500 at the 6-8 leaf stage further samples were analysed for nitrate-nitrogen. Petiole values here were 14,000-29,000 parts per million dry basis except for one necrotic sample, but by this time the plants were at the runner stage i.e. more mature than suggested for the standard. There was no suggestion of deficiency of nitrogen.

Nitrate-nitrogen and extractable phosphorus were also determined on leaves from a Department of Agriculture experiment on the same property. The compound fertiliser Agran at 33 lb per acre

as a source of nitrogen gave 3,100 to 8,000 parts per million of nitrate-nitrogen in the petioles at the 6-8 leaf stage suggesting that a little more nitrogen was needed.

4. Grape Vines.—Much of the work with grape vines is reported under the heading of Air Pollution.

(a) Leaf blades and petioles of vines from recent plantings at Mt. Barker and Frankland River were analysed for 10 elements to obtain an idea of nutrient status in these areas. The most significant findings were at Frankland River where low potassium (blades 0.6 per cent dry basis) were associated with high levels of calcium and magnesium. Phosphorus at Frankland River was also very high by Western Australian standards at 0.5 per cent.

(b) Poor areas of currants at Swan Research Station were associated with chloride and sodium in the blades and petioles. Comparative figures for poor and healthy vines are given in Table 9.

Table 9

CURRANT VINES

	Poor		Healthy	
	Blades	Petioles	Blades	Petioles
	range of per cent of dry matter			
Chloride, Cl	0.61-1.10	1.89-2.76	0.47-0.61	1.64-1.93
Sodium, Na	0.18-0.39	0.77-1.09	0.13-0.23	0.47-0.74

(c) In seeking critical levels of nutrients for different varieties of grapes, work with muscats suggested potassium as a dominant factor with some muscats growing in the Swan Valley, with concentrations relative to vine vigour of:

Vigour	Potassium K per cent dry basis
weak	0.55
medium	0.71
strong	0.79
very strong	1.30

5. Peanuts.—(a) One of the crops on trial at Kununurra is peanuts. Kernels harvested at various digging times after two different times of planting were analysed for comparison. It was expected that nuts will have to be left in the ground for variable periods under commercial conditions with mechanical harvesting and thus produce varied and increasing free fatty acid contents and consequent differences in quality.

The first harvest in both cases contained the highest amount of free fatty acids—about 0.6 per cent for the December digging, falling to about 0.1 per cent for the two subsequent harvests at about 3 weeks intervals. The March planting was only 0.4 per cent for the first harvest, falling gradually to 0.1 for the fourth and with only very slight rises for two subsequent diggings. If confirmed by subsequent experience this appears to have been one anticipated problem which proved unreal.

Since protein content of the kernels is important for confectionery use these samples were also compared for protein content. For plantings made in either December or March and with a growing period of about 140 days, there was appreciably more protein from December planting for each of 8 varieties, 27.5 to 30.9 per cent dry basis, than for the March, 18.9 to 24.7. However the oil content of December material, 53.3 to 57.8 per cent compared unfavourably with March, 55.0 to 60.0 and the latter crop was also reported to have had the higher yield.

(b) Further peanut kernels analyses involved comparison of air dried samples of 4 varieties against samples which had been dehydrated at 180°F for 24 hours.

The dehydrated material contained about 1 per cent less moisture than the air dried but on a dry matter basis oil and protein contents were unaffected. However there had been a slight breakdown of oil resulting in an increase of 0.06 per cent in the free fatty acid content of the oil in the dehydrated kernels.

## New Crops

Partly stemming from the results of many years research by plant breeders but accelerated by the needs of diversification of crops in the face of difficult marketing, more acreage is being devoted to the growing of sweet lupins primarily for stock feed, and of rape seed for export of the oil seed it produces.

Results required by both the agronomists involved in research and the farmers tackling the growing of these crops either in tentative experiments or on a commercial basis, produced a number of samples and interesting results.

1. Lupins.—(a) 118 samples of seed from lupins grown at Medina and receiving various growth regulatory sprays suggested that further work with some of these was justified when they improved the protein content. The most promising of these was 2,4,5-TP.

(b) Although presenting some technical difficulties the dehulling (decoating or skinning) of lupin seed is a means of improving the grain from the feed point of view by removing fibrous material and upgrading the protein. Table 10 shows some results for whole seed, decoated seeds and the seconds—the material produced in the decoating which still has some feed value.

Table 10  
SWEET LUPINS

	Whole	Decoated		Seconds
		1	2	
		per cent		
Moisture	9.6	10.5	12.4	11.6
Ash	2.6	2.3	2.6	2.4
Crude protein	27.9	37.8	36.2	8.4
Crude fat	5.4	7.1	6.8	1.6
Crude fibre	12.2	2.1	2.0	41.4
Nitrogen free extractive	42.3	40.2	40.0	34.6
Calcium, Ca			0.06	0.48
Phosphorus, P			0.36	0.10
Calorific value	calories per gram 4,310	4,500		

2. Rapeseed.—(a) A pool on rapeseed was conducted on the crop grown in 1970. Oil content analyses were performed for the Grain Pool on rapeseed from silos at Albany, Esperance and Fremantle.

(b) Samples from experimental work at Mt. Barker showed that the varieties Arlo and Target gave seed of similar oil contents, averaging 48.8 per cent on a dry basis, but Target contained a higher proportion of protein, 20.3 against 18.9 per cent dry basis.

For the one variety the oil content, which was affected by seeding rate, was inversely proportional to protein content. The use of urea fertiliser improved this situation e.g., for a protein content of about 19 per cent, one per cent more oil was obtained by urea treatment.

(c) Rape plant tops from a pot trial testing the placement of fertiliser in relation to rape seed, were analysed for nitrogen and phosphorus.

Drilling the nitrogen either with or one inch below the seed gave comparable results, both superior in nitrogen content of the tops to other nitrogen fertilisation. Consistently high phosphorus levels were obtained by drilling one inch below or one inch to the side of the seed, but drilling with the seed or one inch below were almost as effective when nitrogen was also added.

(d) The setting up of the gas chromatograph although not completely satisfactory permitted the determination of the fatty acid composition of the oil extracted from so called "erucic acid free" rapeseed. This seed is to be used by the plant breeders for bulking up and cross-breeding since rapeseed oil of low erucic acid content is preferred by the buyers. Compared with the variety Arlo it will be seen in Table 11 that oil lower in erucic acid has a much greater content of oleic acid, a shorter carbon chain molecule with the same degree of unsaturation. The number code following the name of the fatty acid indicates firstly the number of carbon atoms, and the numeral after the point shows the number of double bonds i.e. the degree of unsaturation.

Table 11

	RAPESEED			
	Erucic Acid Free		Arlo	Target
	1	2	per cent as received	
Oil	42.0	45.4	44.2	47.1
	per cent of oil			
Fatty Acids—				
Palmitic (16.0)	4.9	3.8	2.8	4.0
Palmitoleic (16.1)			<0.3	
Stearic (18.0)	1.0	0.7	<0.3	<0.3
Oleic (18.1)	58	68	19	59
Linoleic (18.2)	22	16	13	18
Linolenic (18.3)	7.8	6.8	7.2	8.8
Arachidic (20.0)	0.8	1.0	<0.3	<0.3
Eicosenoic (20.1)	1.3	1.6	14	3.6
Eicosadienoic (20.2)			<0.3	
Behenic (22.0)	0.8	0.7	N.D.	<0.3
Erucic (22.1)	0.4	0.4	44	6.8
Lignoceric (24.0)	2.0	0.4	<0.3	<0.3
Nervonic (24.1)			<0.3	
Tetracosadienoic (24.2)	N.D.	N.D.	<0.3	<0.3

N.D. indicates not detected, the limit of detection being approximately 0.1 per cent.

## Fertilisers

1. Fertilisers Act.—(a) There were 262 samples of fertiliser received for testing for compliance with their registered analyses. This was an increase of approximately 90 per cent. over last year. 229 Certificates of Analyses were issued, 7 being for samples carried forward from 1970, and 40 samples were carried forward into 1972.

Deficiencies were found in 68 of the reported samples and a total of 99 individual deficiencies. The improvement in trace element superphosphate mixtures was maintained, but deficiencies in "water soluble potash" were prevalent in the mixed fertilisers such as potato manure.

Only one umpire sample was called for, in this instance to check on a deficiency of nitrogen in a urea.

(b) Following an overseas report of toxic levels of boron being found in sulphate of ammonia, stocks available in this State were checked by 7 samples from several sources. All but one contained less than 5 parts per million of boron, the exception containing only 16 parts per million. Boron would be a possible hazard particularly at Carnarvon with its already high incidence.

2. The 14 samples of limestone, limesands etc. reported were from many sources, but primarily from farmers wishing to correct soil acidity on their own properties.

The major exception was imported Japanese limestone proposed for lime pelleting of clover seed. The grey colour suggested contaminants possibly either toxic to or inhibitive of rhizobial or plant growth, but was probably attributable to the small amount of iron and traces of manganese and copper found.

The sample was examined spectrographically and no element was detected as present at levels unsuited to pelleting.

Another sample of Japanese limestone was compared with samples of local and South Australian for the purpose of adding to poultry feeds. The South Australian rock held the market for this and other purposes in Western Australia.

	Local	South Australian per cent	Japanese
Calcium, Ca	29.6	34.8	40.2
Magnesium, Mg	0.89	0.23	0.30
Acid insoluble	22.7	12.2	0.8
Silica, SiO <sub>2</sub>	16.2	2.9	0.3

## Soils

1. Sampling.—Samples taken from the site of long term rotation trials using two sampling tools were compared. The first technique—the old method—was to use a 2 inch soil auger taking samples to 3 inches and the new method used a 1 inch hollow spear to 4 inches. The latter is



the tool employed and marketed by a commercial soil testing service and more simple to use in practice.

28 sub-samples was the usual intensity of sampling to provide each composite with the old method. The new was tried at 28, 56 and 112 per composite. The soils were analysed for pH, the greater than 2 mm fraction, organic carbon, nitrogen and cation exchange capacity

All samples gave comparable results and there was no need to increase sampling intensity with the smaller diameter tool.

The auger samples from this experiment were incubated at field capacity at 75°F for one week to provide conditions simulating but more extreme than the effects of opening rains to see whether, for these experiments and parameters measured, samples taken after these rains would be adequate. Very small and probably not significant losses took place in the organic constituents, which related back to the field conditions was interpreted as permitting sampling after the opening rain.

2. Nitrogen.—To test the effects of cultivations and spray treatments for weed control on soil nitrogen, samples were submitted from both Avondale and Wongan Hills Research Stations from the time of cultivation in late May through to when analytical results showed minimal levels of both ammonia and nitrate nitrogen in August.

Only at Wongan Hills was there a marked influence of the treatments. Here the cultivated plots increased in nitrate nitrogen from 3 to 10 parts per million while the ammonia nitrogen remained constant at 2 parts per million. Spray treatments had no effect, ammonia and nitrate nitrogen remaining at about 2 and 3 parts per million respectively.

At Avondale there were no treatment effects, and variations appeared to be the result of leaching from rain which fell before the 2nd and 5th samplings. The ammonia nitrogen declined steadily over the sampling period from 7-14 parts per million to about 2.5 parts per million in all plots.

At both research stations, samples buried and collected at the next sampling showed nitrification of the soil and a corresponding drop in ammonia.

3.—Sulphur. The absorption or desorption of sulphate onto or from a soil in equilibrium with known sulphate solutions can be used to characterise soil/sulphate interactions. This is valuable in predicting both the availability of sulphate to the plant and the required fertiliser treatment.

164 soils from various sulphur status trials in different rainfall areas, and 210 soils from five continuous cropping experiments were analysed for sulphate adsorption characteristics. The soils were equilibrated with sulphate solutions in the range 10 to 50 parts per million of sulphur, and the amount which would be adsorbed or desorbed to give an equilibrium concentration of 20 parts per million sulphur calculated from individual graphs.

Indicative of the different soil to sulphate interactions were two soils from Busselton, one of which had an adsorption of 11 parts per million and the other a desorption of 6.1 parts per million of sulphur. The initial soil sulphate sulphur concentrations were 3.7 and 6.4 parts per million respectively.

All but three of the soils had adsorption or desorption values of less than 15 parts per million. The exceptions were from high rainfall areas, one at Armadale and two at Manjimup which had adsorptions of the order of 30 parts per million of sulphate sulphur.

#### General

1. Air Pollution.—(a) Samples of locally manufactured phosphatic fertilisers and of the basic material rock phosphate were analysed for fluorine and phosphorus.

In the manufacture of phosphate fertilisers practically all the phosphorus in the phosphate rock from which they originate is found in the final product. Changes in the fluorine to phosphorus ratio therefore indicate the amount of fluorine removed in the manufacturing process either in by-products or effluents.

The bulk of Western Australian phosphate fertilisers is made from a blend of Nauruan and Christmas Island rock phosphate. Nauruan rock is generally higher in fluorine than that from Christmas Island but the trend has been for an increased fluorine content of the latter also.

The F/P ratio of Christmas Island rock has varied from about 0.07 for samples received in the 1950's and early 1960's up to 0.13 for later material. Nauruan rock has given up to 0.28. Recent admixtures have had a mean ratio of about 0.16.

The manufacture of plain superphosphate from rock phosphate and sulphuric acid results in little change in the F/P ratio but the high analysis fertilisers involve other steps and the marked reduction of the F/P ratio to of the order of 0.03 to 0.06.

This is not to say that one type of manufacture is a better or worse source of atmospheric pollution than the other. The loss of only a few hundred parts per million of fluorine by a large bulk of rock, which would not be shown by figures such as these, could be more serious if not efficiently scrubbed, than losses of the order of percentages in a plant with adequate controls.

(b) Tissue testing of plants from a number of areas was carried out in relation to presumed or anticipated pollution problems as follows:

- (i) Grape vine leaves from the Swan Valley were tested for fluoride, chloride and inorganic sulphur both routinely, after weather conditions had produced local concentrations of flue gases, and in relation to experiments to see whether lime spraying would reduce fluorine absorption.
- (ii) After a survey had shown that the native peppermint tree *Agonis flexuosa* was ubiquitous, its foliage, together with pasture from grazing properties, was chosen for bi-monthly sampling in the area of Picton. The isolated superphosphate works was chosen for study because of the absence of other potential sources of fluorine.
- (iii) A comparison of leaves of banksia and exotic foliage from the Kwinana region and of similar leaves from trees remote from Kwinana showed that the closer to the industrial complex the higher the aluminium, up to 7000 parts per million and also the higher the inorganic sulphur, up to 0.36 per cent in the dry matter.
- (iv) Other foliage tested came from box, tuart, Norfolk Island pine, Moreton Bay fig and other elements tested for included nickel, manganese and lead.

#### ENGINEERING CHEMISTRY DIVISION

The total number of samples registered to the Division during the year was 150—again an increase over previous years. Although a large proportion of these registrations were concerned with coal, char and similar materials, the remainder represented a wide range of investigations made on a variety of topics. A continuing demand for investigational and testwork from both Company and individual Sponsors again rendered it difficult to progress on general research topics of Departmental instigation. These sponsored investigations were carried out on a "public pay" basis and the details and results remain confidential to the Sponsor.

#### Staff and General

The existence of two vacancies at Project Leader level was a handicap particularly in the first half of the year, but in all other categories the Staff was stable. Mr. R. V. Field, who had resigned from

the Staff at the end of 1970 was reappointed to a position of Chemist and Research Officer, Grade I, in June of 1971, but the vacancy at Grade 2 level was still being negotiated at the end of the year.

Mr. B. Goodheart presented a paper dealing with "The Titanium Mineral Industry of W.A. and Methods of Producing Rutile Substitutes" to the Perth Branch of the Royal Australian Chemical Institute in May.

Mr. L. Brennan continued to be an active member of the Scientific Advisory Committee appointed under the Clean Air Act. The Government's recognition of the need to adopt an increasing role in technological matters in this area has resulted in increasing demands on the Advisory Committee and Mr. Brennan has been appointed to three sub committees dealing with Fluorine, Incineration and Timber and Wood working wastes respectively.

Mr. B. Goodheart was again Western Australia's non voting representative on the Board of Directors of the Australian Coal Industry Research Laboratories.

Field Trips—During the year Messrs. L. Brennan and A. Bright made a visit to Collie to inspect the mines and local industry and B. Goodheart visited several South West mining centres in June and Kalgoorlie and Kambalda in November.

#### *Buildings and Equipment*

A full maintenance and renovation (including the painting of some areas for the first time) of the pilot plant building and ancillaries was carried out during the year and in conjunction with this overhaul, equipment and facilities were partly reorganised to enable co-ordination of the four main areas of Divisional activity, namely:—

- Fuel investigational work and analysis.
- Mineral Processing.
- Hydrometallurgy.
- Pyrometallurgy.

The pilot plant scale rotary kiln, which is 14 inches in internal diameter and 16 foot overall length, has been an important unit in many of the Division's major investigational projects and was again much in demand in 1971. Modifications to the kiln shed were commenced late in the year and these included an overall elevation of the roof to afford increased "head space" for feed hoppers and attachments, and an extension of the enclosed area to enable improved instrumentation and control.

A Davis Tube Magnetic Test unit was acquired during the year to fill a void in the range of equipment available for laboratory scale wet processing and separation of minerals.

The main operating variables are field intensity, tube oscillation rate, wash water and feed rates, and the unit is particularly applicable to fine feed sizes.

Tests to date verify that good quantitative accuracy of separation can be achieved. For an example, a titanomagnetite ore containing approximately 60 per cent. magnetics was ground to three different sizes and then fed to the separator in triplicate batches. After a single pass for each material the maximum variation in triplicate results was as follows—

- 100 mesh (B.S.S.) feed 1.2 per cent.
- 200 mesh (B.S.S.) feed 0.2 per cent.
- 325 mesh (B.S.S.) feed 0.5 per cent.

A laboratory version of a rotating cone concentrator was designed and built in the Division during the year. The cone is of 2 ft overall diameter and 8 inch vertical height. The unit is capable of processing a wide range of materials and sizes and will be complementary to larger scale gravity concentrating equipment (Humphrey spirals and Wilfley table), already in the Division.

#### *Divisional Projects*

Subject to the priority pressures of Sponsored work, some progress was made in projects initiated from within the Division.

(1) Upgrading of Ilmenite—Although a general world wide reduction in demand for most minerals occurred in the latter part of the year and provided relief for the rutile market, which had been facing a serious supply and demand imbalance, the research efforts to perfect a process for upgrading ilmenite to produce a rutile substitute continued at a vigorous pace. The process, which was innovated in this Division some years ago, and which has been fully developed by a Company operating in the Capel area, ranks high on the list of potentially viable processes. Lately a good deal of attention has centered on final product quality and further work has been carried out in this Division to ascertain whether an upgraded ilmenite of chemical and physical properties comparable with those of rutile can be produced.

A broad outline of envisaged variations to the original process, consisting mainly of sulphur doping and sulphurous acid leaching steps, was included in the 1970 Annual Report.

During 1971, effort was concentrated on confirming the control parameters for these additional steps and on obtaining a precise indication of the influence of the sulphur doping variation on final product quality.

A very high degree of metallisation was obtained during static bed reductions in the presence of sulphur. It seems probable that under these conditions manganese sulphide forms stoichiometrically and preferentially to iron sulphide and that the lattice mobility of both iron and manganese is enhanced in sulphur-rich zones. This is seen as a likely explanation for the enhanced metallisation and subsequent easier removal of iron and manganese in the leaching step. This tight association between manganese and sulphur and the formation of manganese sulphide preferentially to iron sulphide was verified by examining reduction products under the electron probe microscope (courtesy of C.S.I.R.O. Division of Applied Mineralogy).

Employing a reduction temperature of 1050°C and the addition of small percentages of sulphur (2-3 per cent of weight of ilmenite) enhanced removal of iron and manganese was obtained during the subsequent aeration and sulphurous acid leaching steps. One marked advantage of this modified reduction step is evident in the lower temperatures that can be used—this leading to less trapping of iron and manganese by the titanite lattice and also lower fuel costs. The sulphur may conveniently be added in the form of pyrites.

An indication of the influence of sulphur doping on the various constituents of the intermediate and final products can be gauged by reference to Table 12 which compares a control experiment (without sulphur addition) and an identical trial with sulphur used at an addition level of 3 per cent.

In these trials, preoxidised (900°C) ilmenite and char mixed in a 1 to 1 ratio was reduced batchwise at 1050°C (2 hours at temperature). One batch contained 3 per cent sulphur addition. The two reduced ilmenite batches were magnetically separated and then each aerated at 15 per cent solids, in the presence of ammonium chloride and acid—the reaction being completed in 14 hours. After separation each aerated product was leached for 2 hours at 40°C with sulphur dioxide introduction at the rate of 350 ml per minute. The final products were washed, dried and then roasted at 800°C for 2 hours. Analyses of intermediate and final products are listed in Table 12 which overall indicates an improved removal of iron and manganese for the sulphur doped series. The final iron and manganese contents of the upgraded product are of the order likely to be acceptable to consumers of synthetic rutile. The roasting step was introduced to lower the sulphur content of the product to satisfy the low values demanded by welding rod manufacturers.

Table 12

INTERMEDIATE AND FINAL PRODUCT ANALYSES  
NORMAL AND SULPHUR DOPED TRIALS

Constituent	Reduction Product	Aeration Product	Sulphurous Acid Leach Product	Roasted Product
<b>NORMAL REDUCTION</b>				
	per cent.	per cent.	per cent.	per cent.
Total Fe	32.0	6.6	5.38	6.10
Metallic Fe	28.8	0.4	N.D.	N.D.
Total Mn	1.27	1.43	1.55	1.48
Total S	0.03	0.01	0.02	0.01
SiO <sub>2</sub>	1.27	0.89	1.09	0.85
Al <sub>2</sub> O <sub>3</sub>	1.08	1.35	1.35	1.31
TiO <sub>2</sub>	62.5	87.1	87.9	87.3
<b>SULPHUR-DOPED REDUCTION</b>				
Total Fe	29.9	4.00	1.65	1.51
Metallic Fe	29.1	1.12	N.D.	N.D.
Total Mn	1.16	0.50	0.25	0.27
Total S	1.59	1.76	1.41	0.03
SiO <sub>2</sub>	1.33	0.99	1.11	0.96
Al <sub>2</sub> O <sub>3</sub>	1.18	1.46	1.34	1.37
TiO <sub>2</sub>	63.6	90.2	94.7	94.9

N.D.—Not Determined.

(2) Spontaneous Combustion—Some trial shipments of Collie coal and coal char to prospective overseas markets have been completed successfully and these can be used to offset the reputation that Collie coal has in respect of its liability to spontaneous combustion. Some work has been done on the subject during the year and a review of the literature has indicated some lines of investigation which will be pursued as opportunity arises. As well inquiries are being made with other institutions which have investigated the phenomenon.

Spontaneous combustion occurs because heat is generated in a coal heap by aerial oxidation, moisture transfer and other surface characteristics. This heat can be dissipated generally throughout the heap and can also be dispersed by natural convection. When the rate of heat generation exceeds the rate of dissipation the temperature of the coal may rise to a dangerous level. In this condition in the presence of an adequate supply of oxygen the coal will probably ignite.

Much of the literature concerns coal mines and in this respect Collie coal is relatively trouble free. Some of the parameters which affect the shipping of coal are—

- (i) size distribution of coal;
- (ii) period of time between mining and shipping;
- (iii) initial temperature of coal (as a function of seasonal variations);
- (iv) conditions of storage in the hold as they affect the circulation of air through the heap;
- (v) nature of gas evolved from the coal during transport.

A full investigation of these factors is currently beyond the Division's resources but the general topic will be examined when time permits.

(3) Pelletising.—The involvement in a sponsored project, created an awareness of the need for a thorough appraisal of design problems associated with the achieving of a consistently reproducible pelletising technique for application to laboratory scale testwork.

When processing fine materials (for example minus 325 mesh B.S.S., hematite), the lack of fluidity of the feed material creates difficulties in feeding to the pelletising drum or disc at a constant rate when using conventional methods. This is mainly because of erratic flow from the hopper to the distribution device. It was found that a variation of more than 2 per cent of the chosen feed rate

over a 20 minute balling cycle, significantly influenced the resulting pellet composition and properties. Hoppers incorporating vibrator attachments, brush feeders and stirring devices together with vibrator tray or belt feeders did not give the desired result. A scraper mounted so as to remove the lower circumference of a natural cone of feed was also unsuccessful for the reason that not all finely ground powders readily formed a natural cone. Finally accurate and consistent feed rates were achieved by using a mildly fluidised bed of feed incorporated within a screw feeder system. The design and operating procedure was such that the tendency for size classification was minimised. Average wet pellet strength was found to be very sensitive to small changes in overall moisture content. As little as 0.05 per cent. variation in total moisture content resulted in significant strength variations and clearly highlighted moisture content to be a most important criterion affecting wet pellet strength—a finding contrary to the emphasis of much of the published literature on this topic. Humidity effects influenced the production of pellets and subsequent strength testing. Storage of freshly produced pellets in a fully saturated atmosphere induced softening, which was evident after strength testing of individual pellets in sequence. In an unsaturated atmosphere, the pellets hardened rapidly. To obtain precise comparative testing of individual pellets, a method in which the freshly prepared pellets were stored in a confined space and tested as quickly as possible was the best.

Other aspects that are listed for further study are the establishing of parameters for the variation in individual pellet strengths within a test batch and defining the properties other than particle size distribution and specific surface of similar raw materials which may influence final pellet strength.

#### Inter-Departmental

##### (1) Coal—Exploration Samples

(a) Collie area:—an assessment of all results was made following the individual analysis of 51 core samples submitted by the Geological Survey in conjunction with the Collie drilling programme recommended by Messrs. Menzies and Hanrahan (Eastern States Consultants). Potential commercial prospects dictated the selective bulking of individual cores to produce "composite" samples from similar seams. From this five bulks were selected for detailed analyses and these were representative of the following seams and areas.

Wyvern seam—Collieburn area

No. 2 seam—Collieburn area  
 Griffin seam—Collieburn area  
 Stockton seam—Shotts area  
 Wallsend seam—Shotts area

These detailed analyses, which included proximate, ultimate, ash analysis and reactivity determinations were close to completion at the end of the year.

(b) Perth Basin:—57 coal bearing samples from various bore holes in the Perth basin were submitted by the Geological Survey. Proximate analysis, calorific value, sulphur and caking characteristics were determined and reported for all samples. Further testing, including carbonisation properties is in progress. At this stage the finds do not seem likely to be of commercial significance and may be of most benefit for the prediction of the geological history of the strata by reference to the rank of the coal.

(c) Mount Anderson (South of Derby):—a sample taken at a depth of about 50 feet from Windmill Well No. 6 was submitted by the Department of Native Welfare. The analysis was as follows:

	Per cent.
Moisture	3.4
Ash	9.6
Volatile matter	36.8
Fixed carbon	50.2
Sulphur	0.6
Calorific value	Btu per lb.
as analysed	12170
dry, ash free basis	13990

There was a partly coherent residue after the volatile matter determination and this indicated that the coal possessed weakly caking characteristics and suggested the sample to be one of above average interest. It was recommended that further investigations be made to evaluate the potential of coal from this area.

(2) Sizing of Dusts:—The Public Health Department enlisted the aid of the Division to prepare suitable feed materials for its experimental programme of observations on the changes induced in the lungs of rats after subjection to iron ore dusts of specific concentration and sizing. A hydrocyclone (4.5 mm diameter vortex finder and 3 mm diameter apex outlet) operating in closed circuit with a Mono pump (50 gallons per hour at 25-30 p.s.i.) with associated feed and recirculation was an effective system for preparing the requisite product (sized at 100 per cent. less than 20 micron and 90 per cent. below 5 micron). Various product batches of iron ore dusts were prepared and attention directed to selected "blank" materials such as precipitated iron oxide, calcium carbonate and titanium dioxide.

#### Sponsored Projects

Details of investigations carried out under a "Public Pay" heading remain confidential to the Sponsor, and only broad aspects of some of the larger projects are listed.

1. Ilmenite and Beach Sand Minerals:—Stage IV trials on ilmenite upgrading were completed and reported to a local mining company. This work was initiated in 1968 and had progressed through various stages, and the latest results suggested the need for verification of findings on a continuous pilot plant scale.

Another beach sand company requested assistance in its studies of an ilmenite upgrading process. Two separate problems were investigated. The first embraced bench and pilot plant trials on possible methods of influencing the quality of upgraded ilmenite. The other investigation was based on a set of trials, also at pilot plant level, aimed at determining the rate controlling mechanism of the hydrometallurgical stage of the process.

Negotiation is in hand to protect some of these findings by lodging an application for a provisional patent in the joint names of the Government and the sponsor company. Another company with plans to construct an ilmenite and secondary mineral production plant in the South West of the State enlisted the aid of the Division in the carrying out of trials associated with the design of their process flowsheet.

2. Titanomagnetite Ores:—56 samples were submitted by one exploration company for beneficiation trials based on magnetic separation. The objective was to concentrate the individual constituents to marketable grades.

Another Sponsor submitted a parcel of vanadiferous titanomagnetite ore for gravity concentration trials and determination of heavy mineral content.

3. Pelletising of Iron Ores:—Experimental work which commenced in 1970 at the request of a major chemical company was completed during the year. The results of 69 separate trials, that had been aimed at establishing the effect of certain additions to the normal commercial pelletising circuit, were forwarded to the Sponsor.

4. Processing of Diatomaceous Earth:—During 1971 there was an upsurge of interest in the possibility of using W.A. diatomaceous earth deposits for market requirements, which are at present satisfied by importing expensive materials from overseas. The Division received many enquiries seeking information on this topic and in response to a request from one syndicate, testwork (centered around rotary kiln calcination) was undertaken to obtain preliminary data of value for the prediction and design of a commercial flowsheet.

5. Cobalt and Nickel Recovery:—This investigation was commenced near the end of the year to examine possible methods of recovering values from local refinery residues. A comprehensive literature search and market assessment were used to define guidelines for the experimental work. Pyrometallurgical and hydrometallurgical tests were under way by the end of the year.

6. Spontaneous Combustion:—A coal mining company authorised a set of trials which enabled graphical comparison and evaluation of the relationship between temperature and certain of the characteristics of the coal sample supplied.

7. Refractories and Bricks:—Several samples were submitted by various Sponsors for test programmes which included heat treatment (using Etchells type furnace at 1700°C) P.C.E. determination and thermal conductivity measurement.

8. Blast Furnace Slag:—Experimental work confirmed that a product with potential to provide an alternative source of alumina for a basic industry could be produced by processing blast furnace slag.

9. Miscellaneous:—Included in this category were a range of coal, char, gas and general fuel samples submitted by various Sponsors for testwork, together with other undertakings such as crushing and sizing of aggregate bulks (for the Public Works Department) and a visit to the factory of a leading brick manufacturing company to inspect the firing process and carry out measurements of certain kiln variables.

#### Consultative and Advisory

During the year advice was given and discussion held on a wide variety of subjects covered by the range of activities of the Division. These subjects included an evaluation of techniques and equipment for producing aluminium prills from scrap aluminium, the processing of industrial minerals (particularly kaolinite and talc), lime sands technology, the manufacture of lightweight aggregate and the production of copper sulphate from scrap copper.

Appraisals on such topics as the use of optical methods for the beneficiation of ores, the potential use of wheat as a fuel for steam cars, alternative fuels for barbecue usage and methods of calculating accurate heat balances around a rotary kiln system were also carried out in response to requests.

Among the overseas and interstate visitors to the Division during the year were:—

- Mr. D. Horsfall—Anglo American Co., Johannesburg, South Africa.
- Mr. T. C. Lukeman—Senior Market Development Officer I.C.I.A.N.Z. (Melbourne).
- Dr. L. Baker—Senior Research Scientist, C.S.I.R.O. Division of Mineral Chemistry, Sydney.
- Mr. J. Howarth—Manager, K.R.C. Resources, Johannesburg, South Africa.
- Mr. D. White—Manager, Samedan Co., of Australia, Canberra.
- Mr. K. Millership—General Manager, Form Coke Australia Pty. Ltd., Melbourne.
- Mr. T. Marshall—Deputy Director, Chemistry Division, Department of Scientific and Industrial Research, New Zealand.
- Mr. D. J. O'Connor—Associate Manager, C.S.R. Research Laboratories, Sydney.

Mr J. J. Katnic, who transferred to the Sewage Laboratory of the Metropolitan Water Board, had been with the Division for 16½ years since graduating in 1954.

Mr. J. R. Edinger, had been a valuable member of the Staff for 6 years before transferring to the new position of Food and Nutrition Officer in the Public Health Department.

The normal processes of filling the vacant positions were still not finalised at the end of the year.

Samples.—Five thousand eight hundred and eighteen samples were received during the year, being an increase of 28 per cent. on the number received in 1970, and double the number received ten years ago, in 1961.

A broad outline of the variation in numbers for the year 1961 and during the period 1968-1971 is indicated in table 13. (Selected sample groups):

### FOOD, DRUGS, TOXICOLOGY AND INDUSTRIAL HYGIENE DIVISION

As in recent years the work of the Division in 1971 dealt chiefly with samples from the Departments of Agriculture, Police and Public Health, but there was a notable increase in samples received from the Department of Fisheries and Fauna. Lesser numbers were received from other Government Departments, from the general public and from various other bodies.

Staff.—The Division suffered a serious loss during the year when two of its more experienced officers transferred to other Government Departments.

Table 13

Class	1961	1968	1969	1970	1971
Foods—					
Total	815	454	480	623	838
Milks	437	387	302	378	321
Exhibits—alcohol	315	647	1,071	1,037	1,172
Human toxicology	388	814	954	1,074	1,219
Industrial hygiene	335	288	303	430	291
Miscellaneous	710	853	873	823	1,767
Specimens from patients	60	158	196	198	252
Pesticides	160	152	89	129	75
Total samples received	2,901	3,547	4,165	4,558	5,818

Table 14 shows the source and condensed description of samples received during 1971.

Table 14

### FOODS, DRUGS, TOXICOLOGY AND INDUSTRIAL HYGIENE DIVISION.

	Agriculture Department	Fisheries & Fauna Department	Hospitals	Labour Department	Milk Board of W.A.	Mines Department	Other Department- ments	Pay Public	Police Department	Public Health Department	Public Works Department	State Tender Board	Swan River Conservation Board	Western Australian Troutling Association	Other	TOTAL	
Foods—																	
Beverages	60		6					3	12	37						118	
Cereals	15							1		1						17	
Foods (Miscellaneous)	5		6			1	1	1		68						82	
Fruits	25							1		6						32	
Milk	64				178					79						321	
Seafoods		49								209						258	
Various								1		9						10	
Industrial Hygiene—																	
Blood and Plasma								7		5						12	
Fumigation										52						52	
Gaseous				5		18				26						49	
Urine			1	47		3		70		27					3	153	
Various										25						25	
Miscellaneous—																	
Animal tissues	204	243								34						481	
Baits	1								22	1						24	
Criminal						2		2	116							120	
Detergents										3		115				118	
Drugs						2	2	2	102	3						111	
Feeds	400							2		11						417	
Horse doping														4		156	
Pesticides	65					4				1		5				75	
Rape plants	54															54	
Water	7	11						3		22		29				73	
Various	43	11	1			8	9	16	5	29		1			15	138	
Pollution—																	
Maritime							1		17							18	
Surveys—																	
Bunbury												24				24	
Swan River													75			75	
Trade waste								10		2			12			24	
Water		34				10		2			5					51	
Toxicology—																	
Animal	42	26						7	12							87	
Human—																	
Toxicology			3						1,208	8						1,219	
Sobriety			1					272	512							785	
Traffic death									385	2						387	
Specimens from patients			87					2	25	188						252	
TOTAL	985	374	105	52	178	48	13	5	425	2,391	798	64	115	87	160	18	5,818

## Foods

Eight hundred and thirty eight samples of food were received for examination; 178 of these were samples of cows milk submitted by the Milk Board of Western Australia for checking against the chemical standards for quality prescribed by the Milk Act Regulations. 3.4 per cent. of these contained less than the legal minimum of milk fat (3.2 per cent) and 69 per cent. contained less than the legal minimum of solids not fat (8.5 per cent.), while 65.7 per cent. of the samples also failed to comply with the legal standard for freezing-point of milk (0.540 degree C below zero). The proportion of samples which failed to comply with the standards for fat and solids not fat is much the same in 1970, but shows an increase in respect of the freezing-point figures (65.7 per cent. failing to comply as compared with 50 per cent in 1970 and 35 per cent in 1969). In presenting these figures it is emphasised that these analyses apply to Inspectors' samples, for which there was *prima facie* evidence of non-compliance with legal standards.

The distribution of analytical figures is shown in the following Tables:

Milk Fat	
Per cent in sample	Per cent of total samples
Less than 3.00	0.6
3.00—3.19	2.8
3.20—3.49	12.9
3.50—3.74	24.2
3.75—4.00	25.8
More than 4.00	33.7
	100.0

Milk Solids not Fat	
Per cent in sample	Per cent of total samples
Less than 8.00	6.7
8.00—8.24	23.0
8.25—8.49	39.3
8.50—8.74	23.6
8.75—9.00	5.1
More than 9.00	2.3
	100.0

Freezing Point	
Degrees C below zero	Per cent of total samples
Less than 0.510	0.6
0.510—0.519	1.7
0.520—0.529	14.0
0.530—0.539	49.4
0.540—0.550	31.5
More than 0.550	2.8
	100.0

Fifty-four samples of bottled milk from metropolitan and country treatment plants were analysed regularly for residues of organo-chlorine insecticides. Although minute traces of D.D.T., dieldrin etc. were detected in nearly all samples, in no case was the concentration of any one insecticide greater than 0.005 part per million.

The Dairying Division of the Department of Agriculture continued its investigations into milk from individual dairy herds, using selected control samples and milk from farms where pesticides were being used in connection with the growing of vege-

tables or other crops. 64 samples of milk and 85 samples of pasture etc. were analysed for organo-chlorine insecticides as part of their investigations to trace the cause of affected milks.

Towards the end of the year a preliminary survey was begun into the nutritional quality of bottled milk and composite samples from treatment plants were received from the Public Health Department and analysed for iron content.

Investigations were commenced by the Horticulture Division of the Department of Agriculture into the residues of ethylene dibromide remaining in orange juice following varied fumigation procedures. 53 samples of orange juice from experimental treatments were analysed for ethylene dibromide content; in addition a number of fibre packing cartons were also examined to check retention of the fumigant following treatment.

The current interest in the mercury content of fish is reflected in the number and variety of fish received for analysis from the Public Health Department. In collaboration with the Department of Fisheries and Fauna, a survey was organised of fish and crustacea from waters around the West Australian coast, but no abnormal level of mercury was detected in any edible fish analysed to date. Of the various "processed" fish and fish products examined during the year, the only samples which contained more than the "accepted level" of mercury (0.5 part per million) were some imported canned tuna submitted by Public Health inspectors before they reached the local market.

In addition to fish, analyses for mercury were also carried out on other foods, e.g. milk, eggs, chicken tissues and on samples of stock food and stock food ingredients.

Samples of frozen fish and of shell-fish were examined for evidence of incipient putrefaction and various "processed" fish and fish products were submitted for identification of colouring substances.

Further samples of "non-excisable" beverages were analysed for alcohol content, particular attention being paid by the Police and Public Health Departments to the "low-alcohol fermented" drinks which have recently appeared on the market.

Twelve samples of orange juice were analysed for compliance with Food and Drug Regulations, and as a continuing investigation into the fruit juice content of these products.

Samples of brandy and wine were analysed as a check on alcohol content, and where appropriate, concentration of preservative, and a number of "home made" wines were examined for lead content in efforts to trace the cause in a case of lead poisoning.

Miscellaneous foods received and examined during the year included—

- dehydrated foods analysed for their nutritional value;
- imported confectionery examined for cadmium (with negative result) following a report of its detection in another country;
- a variety of foodstuffs analysed for arsenic contamination following illness;
- meat "additives" and dried vegetables for ascorbic acid content;
- varied canned foodstuffs for evidence of and cause of suspected deterioration.

## Human Toxicology

Exhibits were received from approximately 500 cases of sudden death which were the subject of police investigation. Of these, 208 cases, comprising 1060 exhibits were submitted for examination for poisons or physiologically active drugs.

In 101 cases no poison or drug was detected, but in 107 cases at least one poisonous substance or drug was identified as a result of examination. In a number of cases the concentration of the drug made its toxicological significance uncertain.

Details are listed in Table 15.

Table 15

Poison or Drug	No. of cases
Carbon monoxide	35
Pentobarbitone	22
Amylobarbitone	11
Phenobarbitone	6
Thioridazione	5
Quinalbarbitone	4
Amitriptyline	3
Arsenic	2
Carbromal	2
Chlorpromazine	2
Diazepam	2
Methaqualone	2
Paracetamol	2
Strychnine	2
*Various (one of each)	24
Negative	101

\* Bromvaletone, chloral, chloroquine, chromium (from potassium dichromate), codeline, cresylic acid, cyanide, dextromoramide, dextropropoxyphene, dibenzepin, ethchlorvynol, formalin, imipramine, maldison, mandelamine, mercury, methanol, metasystox, methyl phenidate, nitrazepam, nortriptyline, promethazine, thallium, toluene.

In 67 of the 183 cases where a sample of blood was available, alcohol was detected on analysis. The distribution of the blood-alcohol figures is shown in Table 16.

Table 16

Alcohol per cent	No. of cases
Negative	116
Less than 0.080	21
0.080—0.149	16
0.150—0.200	12
0.201—0.250	11
More than 0.250	7

#### Blood Alcohol (Traffic Deaths)

Three hundred and eighty seven samples of blood and/or urine were received in connection with investigations into fatal traffic accidents. Two hundred and nineteen of these were "post mortem" blood samples which were analysed for alcohol as a routine procedure.

The distribution of the analytical blood-alcohol figures for the various categories of persons involved in these accidents is shown in Table 17.

Table 17

#### TRAFFIC ACCIDENT DEATHS

Alcohol per cent	Drivers	Pas- sengers	Pedes- trians	Unknown
	No. Involved	No. Involved	No. Involved	No. Involved
Negative	68	26	20	...
0.050 and less	6	3	2	...
0.051—0.079	4	5	2	1
0.080—0.099	3	1	1	1
0.100—0.149	13	6	2	1
0.150—0.200	11	6	5	1
0.201—0.250	7	...	8	...
0.251—0.300	5	...	6	...
more than 0.300	2	1	2	...
	119	48	48	4

Table 17 shows that 21 per cent. of fatally injured drivers had a blood-alcohol figure of, or exceeding, 0.150 per cent, while the corresponding figure for passengers and pedestrians was 14.5 per cent. and 44 per cent. respectively.

If the "upper limit" were 0.08 per cent., then Table 17 shows that 35 per cent. of drivers had a blood alcohol figure of, or exceeding, this limit.

In presenting these figures it is emphasised that they apply only to the 219 samples of blood received for analysis; it is understood that the actual number of "traffic deaths" in Western Australia during 1971 totalled 338.

#### Blood Alcohol (Traffic Act)

Of the 785 samples of blood received for analysis under the classification of "Sobriety", 781 were submitted by Police and Local authorities in connection with—

(a) charges of driving under the influence of alcohol;

(b) other provisions of the Traffic Act.

Samples included under (a) were those required by the police or traffic inspector or taken from persons who on being charged with this offence, had exercised the right provided by the Traffic Act to have a blood sample taken by a doctor and submitted for chemical analysis.

Samples included under (b) were those taken from persons involved in a traffic accident which resulted in personal injury or damage to property, and where there were grounds for suspecting that alcohol was a factor contributing to the accident. In some cases "breath analysis" equipment was not readily available, or could not be used; in others the sample was requested by the subject exercising his rights following a "preliminary test" or a breath analysis, as provided for in Sections 32B(4) and (5) of the Traffic Act.

Under Section 32AA(1) of the Traffic Act, it is an offence to drive a motor vehicle on a road or public place if the blood-alcohol concentration of the driver is 0.08 per cent. or more. Under Section 32C(4), a blood-alcohol concentration of 0.15 per cent. or more "is conclusive evidence that the person was, at that time, under the influence of alcohol to such an extent as to be incapable of having proper control of a vehicle . . . .".

The results of analysis of samples taken under the provisions of the Traffic Act, are set out in Table 18 the figure being the alcohol content of the blood at the time of the accident or the alleged offence, calculated as prescribed by the Blood Sampling and Analysis Regulations, 1966.

Table 18.

Alcohol, per cent.	No. of Cases
0.050 and less	26
0.051—0.079	36
0.080—0.099	34
0.100—0.149	128
0.150—0.200	221
0.201—0.250	216
0.251—0.300	86
more than 0.300	34
	<b>781</b>

In accordance with established practice, each analysis was repeated independently by another chemist, making a total of 1562 analyses in connection with this work.

Table 18 shows that 557 persons, or 71 per cent. of the total, had a blood-alcohol figure of, or exceeding, 0.150 per cent.; 683 persons, or 78 per cent. of the total, had a blood-alcohol figure of, or exceeding 0.100 per cent.; and 717 persons, or 92 per cent. of the total, had a blood alcohol figure of or exceeding, 0.080 per cent. The corresponding proportions for 1970 were 75 per cent., 90 per cent. and 93 per cent respectively.

The average concentration of alcohol in these blood samples was 0.189 per cent.

#### Specimens From Patients

Two hundred and fifty two samples were received under this classification. These were chiefly samples of urine, blood serum and blood plasma, with smaller numbers of whole blood, hair, nails and gastric washouts. These were analysed in connection with medical examination of patients for clinical purposes as distinct from industrial hygiene and toxicology. The different types of analyses performed under this classification are detailed in Table 19.

Table 19.

Analysis	Number
Arsenic	88
Lithium	83
Lead	54
Thallium	14
Amphetamines	13
Mercury	8
Drugs (general)	6
Fluorine	5
Alcohol	6
Strychnine	4
Copper	3
Ephedrine	2
Methanol	2
*Various (one of each)	7

\* Cadmium, cannabis, codeine, magnesium, phen-  
termine, phenytoin, trichlorphon.

#### Animal Toxicology

Fifty exhibits were received from 26 animal post mortem examinations. Twelve cases were negative while strychnine was detected in 8 cases, ethyl fenthion in 3, arsenic in 2 and fluoracetate in one. From twenty four suspected poison baits submitted for examination, strychnine was detected in four, and thimet (phorate) and trichlorphon in one. A trace of nicotine was detected in another bait which, however, had been packed in a tobacco tin for a container.

#### Industrial Hygiene

Two hundred and eighty nine samples were received during the year in connection with industrial hygiene investigations, and represents a return to the "normal average" of recent years after the marked increase noted in 1970.

One hundred and thirty five of these were specimens of urine from workers in occupations where an actual or potential lead hazard was suspected. Analysis for lead was carried out to assist clinical diagnosis or to provide a "screening" to exclude the possibility of undue exposure.

Of these specimens 72 per cent. contained not more than 0.08 part per million (milligram per litre) of lead (as Pb), 18 per cent. contained 0.09-0.15 part per million, 6 per cent. contained 0.16-0.20 part per million, and 4 per cent. contained more than 0.20 part per million.

Other specimens of urine, blood, hair and nails, were examined variously for arsenic, mercury, fluorine, cyanide, and organo-chlorine insecticides in connection with possible exposure of workers to hazardous conditions.

Inspections were made of working conditions in various factories and samples of air or dust were analysed for—

- (1) lead in a plastics factory where lead stearate powder was used;
- (2) T.D.I. in a plant where "foam" plastic was being made;
- (3) fluorine, manganese and zinc in various samples of air inhaled by workers during welding operations;
- (4) sodium fluoracetate levels during the manufacture of poisoned oats.

A number of inspections were carried out to check working conditions during the unloading of cargo from ships' holds.

These were required as a result of leakage or spillage from containers of chemicals such as cyanides, hydrochloric acid, T.D.I., butyl methacrylate, methyl butyl phenol, and tetrahydrothiophene. "On the spot" assessments were made of the degree of hazard in each case, and advice given as required on ventilation and other measures necessary for safe working conditions.

Following a case of accidental death from carbon monoxide poisoning, a detailed investigation was conducted in collaboration with the Police Department into the exhaust system of a motor launch. Thirteen "on the spot" tests for carbon monoxide were made, and two samples taken for laboratory analysis. The investigation confirmed that under

certain conditions of speed and wind direction etc., dangerous concentrations of carbon monoxide from the exhaust system could build up in the passengers' section of the vessel.

The use of fenclorphos for fly control in schools was investigated in conjunction with the Public Health Department. In two experiments, fifteen classrooms were sprayed with fenclorphos "fogging" mixtures of varying concentrations. Air samples were collected for analysis at intervals after spraying and the amount of fenclorphos "settling out" was assessed by its deposition on glass plates placed in a number of selected positions in each room. Five air samples and fifty nine glass plates were analysed for fenclorphos in order to estimate the interval of time after spraying when the room would be safe for normal use.

Miscellaneous samples received for examination included commercial toluol and rubber cement for the presence of benzene, a "kindergarten" paint for lead and mercury compounds, goods suspected of being contaminated by a cyanide spillage, and an oil filter element for identification of absorbent and quantity of oil retained by the filter element.

#### Pollution

Swan River—Seventy five samples of water were collected and analysed in the first half of the year in connection with the regular quarterly surveys of the Swan River. This work was then transferred to the recently formed Water Division whose laboratories became ready for occupation during the year.

Leschenault Inlet, Bunbury.—The normal summer survey of water from Leschenault Inlet, Bunbury was carried out for the Public Works Department. This work also was transferred to the Water Division from the middle of the year.

Maritime.—Eighteen samples of suspected oil were received for examination during the year. These were fluids alleged to have been discharged by ships into harbour waters and were submitted to establish that they were in fact oil or a similar class of substance, and in some cases to attempt to identify the origin of the discharge.

#### Miscellaneous

Pesticides.—There was a marked decrease in the number of pesticides, as such, received for analysis; the seventy-five samples listed in Table 20 being little more than half the number received in 1970.

Table 20.

Type of Pesticide	No. of samples
Aldrin (diluted emulsion)	5
D.D.T. (concentrate)	1
Dieldrin (concentrate)	9
Dieldrin (solid)	10
Dipping fluids	7
Maldison (concentrate)	8
Monocrotophos (concentrate)	1
Weedicide concentrates—	
2,4-D amine	15
2,4-D ester	12
2,4,5-T ester	3
Various	4

Samples of aldrin emulsion were examined for the Architectural Division, Public Works Department, as a check on the quality of materials used in "white ant" preventive treatments in building projects.

Samples of dieldrin concentrate and technical dieldrin were assayed for the Biological Services Division of the Department of Agriculture, weedicide concentrates were analysed as a measure of quality control for the Weed Control Branch, while samples of maldison concentrate were checked for use in programmes of fruit fly control.



**Criminal.**—One hundred and fourteen miscellaneous exhibits were examined for the Police Department in connection with investigations by the Criminal Investigation Branch. These included 50 exhibits taken from cases of suspected arson in attempts to identify the cause of the fire, 22 exhibits from cases of "explosion", and varied exhibits from alleged assault (e.g. identification of fibres), suspected malicious damage, breaking and entering, traffic accidents, and alleged administration of harmful drugs.

**Drugs.**—25 samples of urine and 2 of blood were examined in connection with suspected ingestion of drugs. In one sample codeine was detected, while in three cases its presence was indicated but positive confirmation was not possible. Similarly methadone was indicated but not confirmed in one sample.

83 varied exhibits submitted by the Police Drug Squad included syringes, powder, tablets, capsules, ointment, vegetable materials, sugar, fruit and a pipe (smoking). In 54 cases where a drug was identified there were 12 of cannabis, 5 of amphetamines, 2 of L.S.D. together with a number of other "prohibited" drugs.

**General.**—One hundred and fifteen samples of detergents were submitted by the Government Tender Board for consideration and advice on their suitability for use in Government Institutions. As in previous years the samples varied from the synthetic detergent mixtures to composite soap powders, laundry adjuncts, liquid soap type cleaners, steam-cleaning compounds, solvent type degreasers and preparations for specialised uses.

Routine examination of samples was undertaken for the Western Australian Trotting Association and 137 samples of horse urine and 8 of saliva were examined for drugs. Following several cases of "positive" results, a number of feed additives and supplements were examined in attempts to trace the source of the "positive" result.

There was a marked increase in the number of samples received for analysis for pesticide residues, chiefly organo-chlorine insecticides. It is estimated that approximately 1200 samples were submitted for this purpose, and that the analysis of all but 200 was completed by the end of the year. The greatest proportion of these samples were received from the Department of Agriculture and comprised samples of milk and pasture (previously referred to under Foods), poultry and stock foods, grass and various grain crops, soils, and animal tissues. The latter were chiefly fat samples from animals grazing under varying conditions of possible exposure to organo-chlorine insecticides. The wide range of concentrations found in different groups of samples reflected the variation in these conditions of exposure.

Samples of water were analysed for the Public Health and Public Works Department as a check on possible contamination by insecticide "sprays" of drinking water supplies.

Data on the concentration of insecticides "stored" in wildlife was investigated by the Department of Fisheries and Fauna and 243 samples of tissue, chiefly liver and muscle from birds, were received for analysis for organo-chlorine, and in some cases, organo-phosphorus residues. These included specific surveys of selected areas and/or species, and a survey to investigate the effect, on the bird population of the area, of aerial spraying for insect control.

Miscellaneous samples received and examined during the year included—

- mine airs for carbon monoxide and "nitrous oxide" content following experimental use of explosives underground;
- samples of canvas in tests to ascertain the cause of fire in a tent;
- tallow for compliance with trade requirements;
- imported novelty toys for identification of suspected harmful components;
- fireworks for prohibited constituents;
- building materials for fire tests;
- plant material for toxic substances;

- wool-branding "paint" for compliance with regulations;
- lubricating and furnace oils for examination for specific purposes;
- materials used in "tanning" operations, analysed for mercury content.

The normal range of enquiries for technical information was received during the year, and expert evidence was tendered in various Courts, as required, by officers of the Division in connection with their official duties.

Mr. N. R. Houghton attended the meeting of the Food Analysis (Reference) Sub-Committee of the National Health and Medical Research Council held in Melbourne in October.

Mr. V. J. McLinden attended the Conference of Forensic Toxicologists held at Adelaide in November.

## INDUSTRIAL CHEMISTRY DIVISION

### Introduction

Two hundred and six samples were examined during the year, a decrease of 27 from 1970, but still higher than the 157 samples in 1969. Twenty-eight samples were "Public Pay" and in addition 8 samples were paid for by other Government Departments.

There has been no reduction in enquiries received and as in previous years there has been considerable consultative work covering a wide range of materials and applications. Enquiries on plastics have constituted a considerable part of this consultative work.

### Staff

- (1) Mr. A. P. Besselaar, Laboratory Technician, was granted leave without pay to enable him to complete his final year of study full-time at the W.A. Institute of Technology.
- (2) Dr. Smith delivered the final lecture of the "Know-Your-Plastics" series organised by the Plastics Institute of Australia.

### Details of Work

#### 1. Routine.

(a) Building materials. A number of samples of building materials were examined during the year.

The State Housing Commission were having trouble with a batch of coloured sand-lime bricks in which the coloured pigment had not been properly dispersed, leaving pockets of concentrated pigment very close to the surface. During cleaning up operations some of these pockets were being exposed and this caused staining of the bricks. We were asked to suggest a method for sealing off the these pockets and hiding the stains already produced. It was found that an exterior emulsion paint seemed to be satisfactory although two coats were necessary.

We now undertake the testing of carpet for use in government buildings, so far specifically for primary schools. New primary schools are being supplied with wall-to-wall carpet in most areas as a means of reducing noise and maintenance costs. It is therefore of considerable value to know which type of carpet is likely to be most suitable. There are many types of carpet available made from both wool and synthetic fibres such as nylon. The tests applied are abrasion resistance, resistance to staining and ease of cleaning, and light fastness. In the test for abrasion resistance a sample of carpet was rotated against an abrasive disc and both weight and thickness loss measured after one and two hours. The various staining agents were those which might be expected in schools, such as soft drinks, milk, ink, shoe polish, etc., a total of 13. Finally, samples of carpet were exposed in our U.V. weatherometer for 100 hours to give some indication of the light fastness of the dyes used. Initially, a visit was made to several primary schools in the Metropolitan area to inspect two major carpet types, tufted wool and needle-felted nylon, after about one year's use. Subsequently five carpets were submitted to the tests described above. Two samples were of 100 per cent synthetic fibre (mainly nylon), needle-felted, resin-bonded

carpet of homogeneous construction. Two samples were of similar type but of laminated construction—in one the needle-felted nylon top layer was laminated to a foamed plastic backing and in the other the needle-felted nylon top layer was laminated to a layer of cheaper fibre, probably natural. The fifth sample was tufted wool carpet.

The results obtained were briefly as follows:

The homogeneous, needle-felted synthetic fibre carpets showed up well in the abrasion test, losing least weight and thickness. The sample with foamed plastic backing was only slightly worse, but the carpet with the cheap fibre backing suffered considerably. The wool carpet also suffered severely but this was in part due to its method of construction and the way in which the test was carried out. In the second hour of the test the sample unravelled and the test had to be stopped, but until this started, wear was worse than the first three samples.

The synthetic fibre carpets were all easier to clean than the wool carpet in the stain resistance tests, but it was evident from our inspection of schools that the quicker the stains are treated the better. In the light fastness test the wool carpet showed no change, the three better quality needle-felted carpets showed slight to moderate discoloration or fading and in practice would probably all be satisfactory, whilst the carpet with the laminated cheap fibre backing was badly affected and could not be recommended. A further four samples of carpet are now being tested but results will not be available until early 1972.

A considerable amount of work has been done on paints during the year largely as a result of requests from the Government Tender Board but also from Public Works Department. For example, 5 panels painted with different types of paint were submitted for testing against steam, phenol and formalin. The room to be painted had to withstand frequent sterilisation with one or other of the agents mentioned.

Five samples of various types of paint manufactured by a small new company were submitted for testing. If found satisfactory the company could submit quotations for Government paint tenders. In fact the four pigmented paints all had poor wet hiding power and were therefore unsatisfactory. The fifth sample was a clear lacquer and appeared satisfactory.

A total of 12 samples of paints made by two manufacturers and supplied to Government Stores were examined as a result of complaints by Government painters. Several samples were found to be satisfactory but others had low wet hiding power and could have caused trouble in practice.

We were asked to examine a paint system to be used on the handrails of the Mitchell Freeway Project. Five samples were submitted and tested appropriately. We were able to make a favourable report.

Some ceramic tiles painted with two-pot polyurethane coatings were submitted for examination. It was intended to paint the tiled walls of operating theatres in one of the major metropolitan hospitals in order to improve the efficiency of sterilisation procedures. Adhesion of the coatings to the tiles was examined as well as the effect of the disinfectant solution on the coatings. In the case of one coating system, samples were supplied on (a) cleaned but otherwise untreated tile, (b) cleaned and hand sanded tile, (c) cleaned and mechanically sanded tile. It was found that the adhesion of the coating to the tiles sanded by either method was no better than on the unsanded tile. The elimination of a sanding operation would greatly reduce the time taken to complete the job.

At the request of the Paint Advisory Committee of the Government Tender Board we are testing 35 samples of paint of the various types required by the Government. These were selected from the quotations supplied by various companies for the paint tender for 1972 mainly on the basis of price. This work is in progress and will be reported early in 1972. In addition we expect to receive another lot of a similar number of samples bought as shelf lines which will be submitted to the same range of tests.

(b) Plastics. Not so much experimental work on plastics was carried out this year, but as already indicated the amount of consultative work was considerable.

Polyethylene film has been used for some time as a moisture barrier under concrete raft floors, the usual thickness being 0.006 inch. There are also available polyethylene materials made by weaving narrow ribbons into a fabric followed by the application of a thin polythene film to one face. We were asked to compare such a fabric with the standard 0.006 inch film as a moisture barrier. Tests applied were a falling weight impact test, a hydrostatic pressure test and a determination of water vapour permeability. In the impact test we determined the height at which 50 per cent of the samples were just penetrated by the falling weight. For the 0.006 inch film this height was 2½ inches and for the fabric 11 inches, a result which was to be expected. The water vapour transmission of both materials was virtually the same and both withstood a hydrostatic pressure of 10 lb per sq. in. for 10 minutes. However, it must be borne in mind that the fabric depends for its impermeability on a very thin film of about 0.001 inch even though only a very small area of film is actually exposed through the weave of the cloth. We did in fact find that in one test of water vapour permeability and one hydrostatic pressure test the material failed. In the case of the hydrostatic pressure test water passed through immediately pressure was applied and the water vapour permeability test gave a value of 38 compared to about 1 for all the other tests done. These two isolated failures can no doubt be explained by the presence of pinholes which are much more likely to be present in a 0.001 inch film than in a 0.006 inch film. It may therefore be wise not to use the woven fabric type of moisture barrier where high hydrostatic pressures are likely to be encountered.

There is a number of factory-coated metal building panels available for external cladding. Some of these products are coated with plastic films, others with paints. We were asked to test seven brands for fastness to U.V. light and to atmospheres containing sulphur dioxide such as might be found near a boiler stack. The test decided upon was the CRL sulphur dioxide test described in BS1391:1952. For the U.V. exposure test we ran the weatherometer under two sets of conditions—one dry and the other both wet and dry by arranging for an intermittent water spray to wet the samples at regular intervals. The "wet-and-dry" condition was the more severe. In both tests the exposure period was for 500 hours. Only one brand of panel failed both U.V. tests because of actual physical deterioration of the coating. The same brand also failed the sulphur dioxide corrosion test. One other brand also failed the corrosion test but was reasonably satisfactory in the two U.V. tests. The other five samples withstood all three tests without film failure but with varying degrees of yellowing or fading of colour or in the case of the "wet-and-dry" U.V. test, chalking. Four of these would probably be considered satisfactory in practice. The seventh sample failed because of poor colour fastness. In the dry U.V. test the golden colour had faded badly after 500 hours, but in the "wet-and-dry" test the colour had disappeared completely after only 200 hours although the plastic film itself was hardly affected at all.

Another type of plastic coating was also submitted to a series of tests. In this case the material was a textured polyurethane coating on plywood in a range of colours. Tests carried out were abrasion resistance, resistance to U.V. light (500 hours), effect of heat (e.g. boiling water, cigarette butts), effect of chemicals and resistance to stains. The product generally behaved quite well in all tests, as was to be expected of a polyurethane. The abrasion test was the falling sand test described in ASTM D968 "Abrasion Resistance of Coatings of Paint, Varnish, Lacquer and Related Materials." As the textured surface of the samples was of course rather rough it was considered of interest to determine the reproducibility of the test on surfaces of different degrees of roughness. Gloss enamel paints and decorative plastic laminates

have a very smooth surface, other types of paints have a rather rougher surface as has compressed board of the Masonite type, whilst a product approaching in roughness the sample under test was the textured pressed board used in suitcases. As was somewhat to be expected reproducibility was found to decrease with the increasing surface roughness.

Two examples of consultative work which did not involve us in any experimental work and both relating to vinyl flooring are of interest. Last year we reported very briefly on a bright orange-yellow stain experienced in a building of Swan Cottage Homes. This year we had a report from State Housing Commission of bright pink stains on a similar type of vinyl flooring. In both cases the flooring was in sheet form and backed with hessian. Examination of samples showed that the stains penetrated right through the vinyl material and appeared to originate from the back. This problem is generally considered to be caused by the growth of certain types of fungi or bacteria in the hessian backing material. The vinyl flooring is bonded to the concrete sub-floor by means of a water-based adhesive which of course produces a closed system of high moisture content in the presence of the alkaline concrete surface for a short time until the water dries out. Under these particular conditions of moisture and alkalinity certain micro-organisms during their growth produce brightly coloured dyes which are absorbed by the vinyl compound and penetrate to the top surface. The most common colour is a bright pink although the yellow stain occasionally shows up and it is interesting that we have experienced outbreaks of both colours. When the water dries out the fungi can no longer grow and no further staining occurs. The problem can be prevented by treating the hessian with a suitable fungicide or by adding a fungicide to the water-based adhesive used. However, once present the stain cannot be removed although it may fade in time.

The second problem was raised by Fremantle Hospital who reported trouble with stains or marks on vinyl flooring in the new children's wing and associated with the rubber-tyred castors on the beds. On checking with another major hospital it was found they also had trouble with marking of vinyl floors on occasion not only with castors but also with crutch tips and rubber-tyred wheels of invalid chairs. The Fremantle problem was discussed by telephone with the Hospital authorities, the bed suppliers and the suppliers of the polish used on the floor. The situation became rather obscure so a visit was made to examine the problem at first hand. It was found in fact that there were two separate problems. The first was the presence of black scuff marks which could in fact be readily removed during the normal course of floor maintenance—unsightly but not very serious. The second manifestation was the real problem and consisted of purplish-brown stains under the castors at the foot only of each bed, the stain being in the vinyl material itself and not removable even by complete removal of the polish. The bed manufacturers reported that the castors at the head of each bed were of one particular brand whilst those at the foot were of another brand. This stain is caused by the use of a staining type antioxidant in the rubber composition used for the tyres and can be prevented by the use of a non-staining type antioxidant. Surface scuffing can also be reduced or perhaps eliminated by using the right rubber formulation.

(c) Miscellaneous.—A roll of photographic film was submitted for checking on thoroughness of fixing. Appropriate tests were applied which indicated that the film had been processed properly.

An accident had happened on a building site during the cutting of concrete when the abrasive cutting disc in use suddenly broke up. The pieces were submitted for examination but no obvious faults could be discovered. It was known that the disc had been used at a rotational speed somewhat greater than the maximum recommended by the manufacturer. These composite materials are also relatively brittle, and the disc if dropped

could have developed cracks which would not have been visible to a casual inspection. A combination of both factors may have been the cause of failure in use.

A total of 57 samples of poor quality coal were submitted for various tests including any possible montan wax content. However it was finally decided that it would be a waste of time to do this determination and no work was done by this Division. However, another separate Departmental sample was analysed for wax content.

A product based on lignosulphonic acid, a by-product of kraft paper manufacture, is used as an additive in concrete to improve its properties. We were asked to analyse a sample to determine lignosulphonic acid and sugars content. If the sugars figure is too high for example, the mixture can act as a retarder for the setting of the concrete. Both values were, however, found to be satisfactory.

## 2. Assistance to Industry

(a) Marine protein concentrate. No further work has been done on this project.

(b) Paints. A building company asked for guidance in the painting of a house where problems had shown up. The house was inspected and recommendations made.

(c) Montan wax. Eleven samples of lignite were analysed for wax content.

(d) Peat wax. Five samples of peat were analysed for wax content.

(e) Plaster.—A local analytical laboratory was having trouble with the plaster ceiling in their building. It had lost strength and was sagging badly. Examination of samples showed that the fibrous reinforcement was no longer acting as a reinforcement because of almost complete loss of strength. One of the operations carried out in the building was the digestion of mineral samples in strong acids, particularly hydrochloric and perchloric acids. The fumes from this operation should normally be vented to the atmosphere via a fume cupboard, but it was thought that wind might have carried the fumes under the tiles and into the roof space. Tests showed that the plaster had an acid reaction, appeared to contain some perchlorate and also a slightly high chloride content, indicating that the explanation given above is probably correct.

(f) Charcoal.—A local company is interested in the production of charcoal from jarrah for export. We were asked to prepare charcoal under certain specified conditions and a total of 9 samples were processed.

(g) Filter Cartridges.—Cartridge filters used for filtration of oil well water on Barrow Island sometimes become blocked with a deposit of calcium carbonate. Rather than throw the blocked filters away an inhibited acid treatment was used to remove the calcium carbonate but the treated filters were found to be much more porous. We were asked to carry out some tests under specified conditions on new filters to determine the effect of acid treatment.

(h) Polyester Resins.—A company is about to start local manufacture of polyester resins. At the request of the Department of Development and Decentralisation we will carry out some tests on a sample of resin prepared on a laboratory scale and received just before the end of the year.

## 3. Investigational

(a) Painting of Karri Timber.—After a little more than one year's exposure the third exposure trial came to an abrupt halt early in the year. Our exposure racks had been erected in the grounds of a depot of another Government Department. During some site alterations and owing to a misunderstanding our exposure racks were demolished and all the panels of the third exposure trial and those remaining from the second exposure trial were dumped. This was not discovered for several months as the panels are only inspected at intervals of 6 months. We were able to recover most of the panels from the second exposure trial but a number of

panels from the third exposure trial were lost. It was therefore necessary to prepare a fresh lot of panels for the third exposure trial. Karri panels to our specification were again supplied through the good offices of the Timber Development Association and one of the major timber companies, various paint manufacturers again supplied free samples of paint and the set of painted panels prepared again. The exposure racks have now been erected in the grounds of our Engineering Chemistry Division at Bentley and all panels have now been set out there.

(b) Peat Wax.—Some work on wax purification was done early in the year but the company concerned then requested us to stop work on the project because there was some doubt whether they would be granted their claims to mine peat. No further work was done for the rest of the year and the continuance of the project is still in doubt.

(c) Printers' Rollers.—The P.V.C. printers' rollers are still under test and performing satisfactorily. Some work was done on flexible epoxy resins but these were found to be quite unsuitable. Study of information supplied on polyurethane prepolymer systems indicated that they were far too viscous for hand pouring and had to be mixed and dispensed by machine. Our first attempt to prepare a polysulphide rubber roller was also unsuccessful, again because it was too viscous. The prepared roller was so full of air bubbles that a smooth surface could not be produced. The working surface of the roller must be perfectly smooth and free from pits, otherwise ink is not transferred evenly.

We have now obtained, after a very considerable delay, a sample of a prepared polysulphide casting rubber from the Eastern States manufacturer and also detailed information on the formulation of these casting rubbers from the American manufacturer of the raw material. A roller cast from the sample gave much trouble whilst being extracted from the mould. It was severely damaged but repairs are being carried out and when completed the roller will be submitted to the Government Printer for test. These polysulphide rubbers seems quite promising since they can be formulated to give a range of hardnesses which should more than cover the requirements of the Government Printer and others. Such rollers are in use in America in particular and possibly elsewhere. In the meantime we will obtain the other raw materials needed to carry out our own formulating and continue the project in 1972.

(d) Lubricating Oil Recovery.—Work on this project was completed after the development of a moderately successful process was achieved.

(e) Polyester Drafting Film.—As a result of interest by a company in the local manufacture of polyester drafting film the Department of Development and Decentralisation asked us to examine the possibilities. A literature survey was carried out as a result of which it was agreed that we should undertake experimental work in an attempt to develop suitable products. The object is to develop suitable coatings on a polyester film base which are both pencil and ink receptive. There must be good adhesion of the initial coating to the film and good intercoat adhesion where there is more than one coat. The literature showed that a wide variety of resins can be used to produce suitable coatings and information on starting formulae was provided by a supplier of polyester film. After some considerable delay in obtaining samples, particularly of various grades of the base film, work has now started on the project. It is of some complexity and we do not anticipate quick results.

(f) Rust treatment.—During the year a literature survey was carried out on rust conversion coatings on steel. There are various treatments which can be applied to rusty steel prior to painting. A widely used process is to pickle the steel in dilute sulphuric or hydrochloric acid followed by a treatment in phosphoric acid. This treatment removes the rust and replaces it with an iron phosphate coating which forms a good base for paint. Phosphoric acid can be activated by addition of phosphates of a number of metals such as zinc, iron, nickel, cobalt, manganese, etc. There are

many preparations of this kind available under a variety of trade names which convert the rust to a complex phosphate coating without the need for the primary pickling operation in sulphuric or hydrochloric acid. Other treatments produce an iron phosphate/tannate coating, a magnetic iron oxide coating and so on. The literature survey showed that there was no information available comparing these various processes and it is the purpose of this Departmental investigation to do so. As the project was only approved in December no actual work has yet been done.

(g) Sawdust Utilisation.—This is not a new problem and much work has been done in various parts of the world. However, in this case there is available about 200 tons per month of wood flour and fine sawdust in Perth which is at present disposed of by dumping. It is becoming more and more difficult to do this as the Metropolitan area expands. It is intended to examine various possibilities such as preparations of activated charcoal, manufacture of chemicals, e.g. tannin, furfural, use as filler for plastics, modification by reaction with active chemicals such as isocyanates, etc. Work has started on activated charcoal since this is a product widely used in Australia and at the present time largely imported.

(h) Potassium and Magnesium Salts.—We received an enquiry for information on manufacture of potassium and magnesium salts from bitterns. Bitterns are a by-product of the manufacture of salt by the solar evaporation of sea water or from natural deposits of such salts and are rich in potassium and magnesium. A literature survey was carried out and a list of references was supplied. However, as it was possible that we might be asked to undertake an investigation of this problem, which is a very complex one, it was decided to study the references in some detail and prepare a report for file in case of future need. The report is now nearing completion.

(i) Rheology of Paints.—As a Departmental project it was decided to undertake a short literature survey in the field of paint rheology. The flow properties of paints are very important in producing satisfactory finishes particularly when applied by brush. A particular type of viscometer, called a cone and plate viscometer, is claimed to give information on the brushability of paints. Such information would be a valuable addition to the test results we already supply to the Government Tender Board. The report is now in preparation.

#### 4. Other Activities

*Scaevola spinescens*.—We have continued to supply an extract of this native plant to a number of cancer sufferers. Several collecting trips were necessary during the year to replenish supplies. The area from which collections are made should continue to supply us for 1972, but after the end of that year a new area will probably need to be found.

The pharmacological work being done under the supervision of Professor Lockett of the Department of Pharmacology, University of Western Australia, was completed during the year and a report is being prepared for publication. Because of limited facilities the investigation was not progressed very far, but it was nevertheless a very useful exercise for the research student who carried out the work. The report should soon be published in *Pharmacological Research Communications*.

Early in the year a sample of the ground plant material was supplied to Dr. Keast of the Department of Microbiology of the University of Western Australia Medical School. His interest in the extract is different from that of Professor Lockett. Dr. Keast reports that preliminary work has shown the extract to be moderately stimulating to lymphocytes. Further work will be necessary to determine whether this result is in fact of any importance. However, all work in the Department of Microbiology was seriously interrupted during the year by a serious fire which destroyed much equipment and valuable records. More work on the extract will be done when time permits.

It is interesting to record that medical reports have indicated in two cases the extract has had an activity similar to that of corticosteroids.

#### 5. Consultative

The following items are examples of the consultative work done during the year.

Production of a protein concentrate from sweet lupin seeds.

Removal of stains from carpets.

Source of supply of water soluble plastic film bags. The Forests Department were interested in broadcasting pine seeds in such bags during dry weather, so that when the rains came the bag would dissolve and allow the seed to germinate.

Advice on reflective aluminium-pigmented and heat resistant paints to Forests Department.

Formulation of artificial brick panels.

Surface colouring of aggregate for use in exposed aggregate panels.

Paints suitable for rail tankers for transport of strong sulphuric acid.

Polyester patching compounds for car repairs.

Advice on preparation of a specification for reinforced plastic septic tanks for Public Health Department.

Removal of the plastic material from encapsulated electronic components.

#### KALGOORLIE METALLURGICAL LABORATORY

Until 1968 the Annual Report of this Laboratory was included with that of the Kalgoorlie School of Mines. That Institution was transferred from the Department of Mines to the Western Australian Institute of Technology from the beginning of 1969 but the Kalgoorlie Metallurgical Laboratory was not so transferred so its Annual Reports for 1969 and 1970 appear separately in the Annual Report of the Department of Mines.

Late in 1971 the Kalgoorlie Metallurgical Laboratory was transferred to the Government Chemical Laboratories so its Annual Report is included here for the first time.

The capacity of the Laboratory to carry out research work and assays during 1969-1971 was limited due to reductions in staff but steps have already been taken to restore staff numbers.

During 1971 four C.S.I.R.O. reports were issued.

No. 761 Jig and flotation tests on antimony ore from Steel's Creek and from Eildon, Victoria.

No. 762 Recovery of scheelite and gold from a cone concentrate from dumps near Southern Cross.

No. 763 Jig versus table recovery of fine scheelite from a dump at Daveyhurst.

No. 764 Jig recovery of coarse lead and zinc from a dump at Napier Limestone Range near Derby.

In addition 23 certificates were issued involving 218 metallurgical tests and 2133 assays. The materials involved were beach and mineral sands, iron and nickel ores and the separation methods employed were electro-static, flotation, gravity and magnetic. A further 311 assays were done, including 157 for gold.

#### MINERAL, MINERAL TECHNOLOGY AND GEOCHEMISTRY DIVISION.

##### General

The total number of samples received (2399) was the lowest since 1964. The number submitted from non-Government sources fell to about half that from the same source in 1970, reflecting a decline in mineral interest from the boom conditions of recent years. There was a slight increase in the number of samples from Government Departments and instrumentalities.

As far as volume of work is concerned there was no falling off commensurate with the decrease in sample numbers. There were, for example, 312 samples submitted for complete analysis, involving in each case ten to fifteen separate determinations, a number considerably in excess of the sum of such analysis for the previous four years.

The source and types of samples handled during the year are listed in Table 21.

Table 21  
MINERAL DIVISION

	Mines Department	Native Welfare Department	Police Department	Public		Public Health Department	Other Government Departments (b)	Total
				Free	Pay			
Building Materials (a) ....	17	....	....	....	14	....	38	69
Complete Analysis ....	310	....	....	....	2	....	....	312
Dusts ....	....	....	....	....	....	565	6	571
Explosives ....	11	....	....	....	....	....	....	11
Mineral Identifications ....	223	48	1	6	225	2	18	523
Miscellaneous ....	17	....	74	....	38	....	6	135
Ores and Minerals—								
Aluminium ....	8	....	....	....	35	....	....	43
Copper ....	6	1	....	....	21	....	....	28
Gold—								
Ores ....	....	....	....	....	70	....	....	70
Tails ....	44	....	....	....	3	....	....	47
Umpire ....	4	....	....	....	....	....	....	4
Heavy Sands	....	....	....	....	47	....	....	47
Iron ....	22	7	....	....	30	....	....	59
Lead ....	7	1	....	....	15	1	....	24
Lithium ....	6	....	....	....	10	....	....	16
Monazite ....	....	....	....	....	15	....	....	15
Nickel ....	11	....	....	2	98	....	....	111
Platinum ....	24	....	....	....	20	....	....	44
Salt and Brines	....	....	....	....	8	....	5	13
Selenium ....	....	....	....	....	16	....	....	16
Tantalum ....	....	....	....	....	26	....	....	26
Titanium ....	38	....	....	....	17	....	....	55
Vanadium ....	1	....	....	1	15	....	....	17
Other....	7	....	....	7	108	4	17	143
	756	57	75	16	833	672	90	2,399

(a) Includes : Concrete, Cement, Aggregates, Bricks.

(b) Includes : Metropolitan Water Supply, Main Roads Department, Department of Industrial Development, Public Works Department, State Engineering Works, Forests Department, Agriculture Department, Department of Local Government, Department of Environmental Protection, Swan River Conservation Board, Commonwealth Department of Works, Postmaster Generals' Department, Navy Department.

## Staff

Personal. Mr. J. Bateman retired in July after twenty-two years service with the Division and Mr. R. C. Morris resigned early in the year. Mr. E. W. Beng was appointed on a temporary basis in May as a mineralogist. During the year Messrs. J. Young and R. Hogg were appointed as Laboratory Technicians, and Mr. K. Renton was promoted from Technician to Chemist and Research Officer. It is with regret that we record the death in a motor accident of Mr. J. Sims who was on the Divisional staff for over 23 years. For many years Mr. Sims was responsible for all the fire assay work and he contributed greatly to the enviable reputation the Laboratories have in this field.

Mr. M. B. Costello attended a course in Automatic Data Processing at the State Computer Centre, and also took over the position as Hon. Secretary of the Royal Australian Chemical Institute.

Mr. P. Hewson became Secretary-Treasurer of the Analytical Group of the R.A.C.I.

Publications.—Two papers were published during the year. "Holtite a new mineral allied to dumortierite" by M. Pryce in the *Mineralogical Magazine* for March and "Analyses of altered struvite from Skipton, Victoria", by P. J. Bridge in the September issue of the same *Journal*.

Laboratory inspections.—Inspections were made of six laboratories that had applied for registration by the National Association of Testing Authorities. Three of these assessments were carried out by Mr. M. Costello, two by Mr. D. Burns and one by Mr. G. Payne.

## Equipment

The Siemens S.R.S. 1 X-ray fluorescence equipment has been used extensively for both qualitative and quantitative work and its usefulness will continue to increase with growing familiarity with techniques.

The Philips PW1130 X-ray generator and accessories are giving every satisfaction and are in constant use for diffraction work.

After considerable adjustments to meet the safety requirements of the State X-ray Laboratory the General Electric X-ray unit is now operational and is used for all Guinier powder work and intermittently for single crystal work with the Weissenberg camera.

During the year, the Guinier camera was set up and aligned with assistance of officers from the C.S.I.R.O. Division of Mineralogy.

A new slide cutting machine of local manufacture has been installed and is proving more versatile than the older equipment.

## Mineral Collections

Collections were supplied on a restricted basis due to limited stocks, preference being given to requests for teaching and museum purposes.

The Western Australia Chamber of Mines, Junior Farmers, and the British High Commissioner were among those for whom collections of Western Australian minerals were prepared while specimen material was sent on request to a number of overseas bodies. These included minyulite, leucophosphite and osarizawaite to the Vienna National History Museum, scheelite to the University of Munich, topaz to Charles University, Prague and holtite to national museums in Paris, London and Washington and the Stanford University, California. A general collection was sent on request to Laboratorio Wassermann, Zavagoza, Spain.

The Mineral Division Collection contained 4742 specimens at the end of the year, being an increase of 176 for the year. Of these only 18 were from localities outside Western Australia (11 from overseas, 7 from interstate).

The overseas additions included gaspeite from the Gaspé Peninsula, Quebec; nephrite and uvarovite from Rhodesia; tyuyamunite from Utah; sabugolite from Washington and crossite from California. Samples from Spain included cinnabar, aragonite and anhydrite. Specimens from South

Australia were mainly radioactive and included carnotite from Wild Dog, uraninite from Mt. Painter and a metamict absite with intergrown rutile from Crocker's Well. Other interstate samples of interest were calciovolborthite from Lake Torrens, varlamoffite from Queensland and curite from Nabarlek in the Northern Territory.

Whenever possible specimens of Western Australian minerals from newly recorded localities were added to the collection. These species are listed elsewhere under "New Mineral Localities".

Other collection additions included a suite of minerals from the Nangaroo Mine at Murrin Murrin, donated by Mr. J. Just of Australian Selection Pty. Ltd., which included paratacamite, atacamite, chalybite, malachite and aurichalcite. Other specimens from the same donor were a cummingtonite—albite intergrowth, pyrolusite, nontronite, nickeloan magnesite and chrysoprase from Pyke Hill, zoisite and oolitic agate from Eucalyptus, chalcantite from Agnew and axinite from Murrin Murrin. Asarco (Aust.) Pty. Ltd. through various field officers donated specimens which proved to contain hausmannite, almandite, fourmarierite and vandendriesscheite from the Arthur River outstation on Eudamullah, variscite in shale from Wanna Station, microcline crystals from Balfour Downs, zinciferous magnetite from Mukinbudin and some striking hematite and goethite pseudomorphs after pyrite and magnetite from Corunna Downs.

Samples donated by Mr. G. Rasmussen of State Batteries Branch included galena and sphalerite from mines at Nanutarra and Northampton, tapiole crystals from Dalgaranga, nickeloan magnesite from Golden Valley, Pyke Hill and Marvel Loch, galena and chalcopyrite (partially replaced by digenite) with coatings of brochantite, anglesite and linarite from the Wheal Fortune Mine at Northampton and the hollow tektite described in detail elsewhere.

A number of specimens collected by Mr. C. Dohnt from the site of the Devonian Lead Mine on Napier Downs Station contained cerussite, brochantite, hemimorphite, smithsonite, chalybite, and sphalerite.

Staff member P. J. Bridge has contributed a great number of specimens collected during private field trips and after examination many of these have been added to the Departmental collection. Among such specimens were vermiculite from Heaney's Find, lead, copper and zinc minerals from Mary Springs L.M., graphite from Northampton, fluorite-bearing pegmatite from Melville, laven-dulan, pharmacosiderite, olivenite from Kundip, alexandrolite from Marvel Loch, "singing" sand from Cape Le Grand, chalybite and sphalerite from Narra Tarra, minyulite from Dandaragan, tripuhyte and tetrahedrite from the Mosaic Mine, Kundip, takovite and laumontite-leonhardite from Widgiemooltha, chalcantite from Ravensthorpe and zinnwaldite rosettes from Melville.

A number of interesting specimens received from Mr. P. Turcaud proved to be goethite pseudomorphs. Most of these originated from the rather remote areas in the Paterson Range in the eastern Pilbara.

All donated specimens are treated in the same manner as samples submitted for examination and report, but with lower priority. Thus all are subjected to mineralogical and/or chemical tests for confirmation of identity before deciding on whether or not they warrant inclusion in the collection.

## New Mineral Localities

In the Annual Report for 1970, beryl is shown as having been recorded  $\frac{1}{4}$  mile from the Badja shearing shed. This is an error, the mineral concerned being baryte, not beryl.

Localities from which specific minerals were recorded for the first time in these Laboratories during 1971 are listed below. Those marked with an asterisk represent species identified for the first time within Western Australia.

(a) Kimberley Division		
Anglesite	....	Castlereagh Hill
Bindheimite	....	16 miles west of Kununurra
Freibergite	....	16 miles west of Kununurra
Famatinite	....	16 miles west of Kununurra
Galena	....	Castlereagh Hill

(b) North West Division		
Allanite	....	Mt. Gratwick
Fuchsite	....	12 miles south of Marble Bar
Gadolinite	....	Coondina, Shaw River
Lavendulan	....	High Range, Mangaroon
Olivenite	....	High Range, Mangaroon
Paratacamite	....	High Range, Mangaroon
Talc	....	Mt. Gratwick
Tanteuxenite	....	Turkey Camp Creek, Lalla Rookh
*Volborthite	....	15 miles south of Marble Bar

(c) Murchison Division		
Antlerite	....	Geraldine
Apatite	....	11 miles NNW of Yalgoo
Atacamite	....	Galena
Beryl	....	7 miles SW of Windsor Homestead
Beryl	....	22 miles NE of Geraldton
Brochantite	....	Wheal Fortune mine
Chromite-magnetite	....	Freddie's Well
Cumengeite	....	Waneranooka mine
Descloizite	....	Galena
Digenite	....	Wheal Fortune mine
Fluorite	....	Melville
Glauconite	....	8 miles NE of Ajana
Hemimorphite	....	Freddie's Well
Hydrozincite	....	Wheal Fortune mine
Lepidolite	....	11 miles NNW of Yalgoo
Linarite	....	Wheal Fortune mine
Magnesite	....	Wheal Fortune mine
Pseudorutile	....	3 miles NNW of Byro Homestead
Rutile	....	3 miles NNW of Byro Homestead
*Serpierite	....	Wheal Fortune mine
Spessartite	....	Melville
Tantalite	....	7 miles SW of Windsor Homestead
Zinnwaldite	....	20 miles SW of Yalgoo

(d) South West Division		
Atacamite	....	Watheroo
Chalcopyrite	....	Watheroo
Diopside	....	Newdegate
Olivenite	....	Kundip
Pharmacosiderite	....	Kundip
Sphene	....	Jarrahdale
Talc	....	6 miles north of Caron

(e) Central Division		
Alexandrolite	....	Marvel Loch
Apatite	....	Marvel Loch
Atacamite	....	Londonderry
Atacamite	....	Marvel Loch
Carnotite	....	Thatcher's Soak
Chalcopyrite	....	Dulcie
Chalybite	....	Dulcie
Chalybite	....	Eulaminna
Chrysoprase	....	Pyke Hill
Cummingtonite	....	Pyke Hill
Galena	....	Dulcie
Laumontite-leonhardite	....	Widgiemooltha
Levendulan	....	Marvel Loch
Molybdenite	....	Marvel Loch
Monazite	....	Holleton
Natroalunite	....	Londonderry
Natrojarosite	....	Londonderry
Nickeloan magnesite	....	Widgiemooltha
Nickeloan magnesite	....	Marvel Loch
Nickeloan magnesite	....	Golden Valley
Nickeloan magnesite	....	Pyke Hill
Nontronite	....	Pyke Hill
Pyrolusite	....	Pyke Hill
Sulphur	....	Londonderry
Uvarovite	....	Marvel Loch
Zoisite	....	Eucalyptus

(f) North East Division		
Bloedite	....	Lake Waukarlycarly
Brochantite	....	Paterson Range
Malachite	....	Paterson Range
Plattnerite	....	Isabella Range

(g) East Division		
Chrysoprase	....	Warburton Range

*Complete analyses*

Most complete mineral and rock analyses were carried out for the Geological Survey or for Departmental information, only two samples (ilmenite concentrates) being completely analysed for outside interests.

A rock from Yundamindra station, believed to be an ultramafic lava, was analysed for the Geological Survey with the following results

	Per cent.
Silica, SiO <sub>2</sub>	40.56
Alumina, Al <sub>2</sub> O <sub>3</sub>	4.58
Ferric oxide, Fe <sub>2</sub> O <sub>3</sub>	5.05
Ferrous oxide, FeO	4.34
Magnesia, MgO	31.50
Lime, CaO	3.65
Soda, Na <sub>2</sub> O	0.08
Potash, K <sub>2</sub> O	0.12
Combined water, H <sub>2</sub> O <sup>+</sup>	8.71
Moisture, H <sub>2</sub> O <sup>-</sup>	0.49
Titanium dioxide, TiO <sub>2</sub>	0.24
Phosphorus pentoxide, P <sub>2</sub> O <sub>5</sub>	0.04
Manganese oxide, MnO	0.14
Carbon dioxide, CO <sub>2</sub>	0.21
Chromic oxide, Cr <sub>2</sub> O <sub>3</sub>	0.24
Sulphur, S	0.04
	Parts per Million.
Nickel, Ni	2100
Vanadium, V	190
Cobalt, Co	260
Copper, Cu	200

Analyst: J. R. Gamble.

Other samples analysed included 4 calcretes from Millstream, Roebourne and Leonora, a greisen from Moolyella and a large number of granites and basalts.

"Pseudorutile"—Black crystals from Greenbushes gave an X-ray diffraction pattern identical with that of the controversial "pseudorutile" of Teufer and Temple (*Nature*, July 9, 1966, p. 179). This "pseudorutile" is described as a new crystal-line phase being a major constituent of altered ilmenite. Complete analysis of the Greenbushes material gave the following figures:

	Per cent.
Titanium dioxide, TiO <sub>2</sub>	60.7
Ferric oxide, Fe <sub>2</sub> O <sub>3</sub>	31.3
Ferrous oxide, FeO	0.70
Silica, SiO <sub>2</sub>	0.51
Alumina, Al <sub>2</sub> O <sub>3</sub>	1.01
Lime, CaO	less than 0.01
Magnesia, MgO	0.16
Soda, Na <sub>2</sub> O	0.01
Potash, K <sub>2</sub> O	0.01
Moisture, H <sub>2</sub> O <sup>-</sup>	0.18
Combined water, H <sub>2</sub> O <sup>+</sup>	2.85
Phosphorus pentoxide, P <sub>2</sub> O <sub>5</sub>	0.05
Manganese oxide, MnO	0.89
Chromic oxide, Cr <sub>2</sub> O <sub>3</sub>	0.08
Vanadium pentoxide, V <sub>2</sub> O <sub>5</sub>	0.06
Antimony oxide, Sb <sub>2</sub> O <sub>3</sub>	0.07
Tungstic oxide, WO <sub>3</sub>	0.77
Lithia, Li <sub>2</sub> O	0.02
Sulphur trioxide, SO <sub>3</sub>	0.16
	99.53

Analyst: R. S. Pepper.

Figures for the major components of the above materials are very similar to those of commercial "ilmenite" concentrates from New Jersey quoted by Teufer and Temple but the ferrous iron content is much lower than similar figures for commercial concentrates from Florida, Quilon (India) and Brazil.

Commercial parcels from Western Australia generally show a lower titanium figure and a very much lower ratio of ferric to ferrous iron.

*Mineral and ore identification and analysis*

**Baryte.** A sample from North Pole contained microscopic liquid inclusions emitting sulphuretted hydrogen when broken. Underground mining of such material would be hazardous in the absence of very efficient ventilation.

**Bauxite.** Of the forty two samples submitted as potential bauxites only 8 showed a soda-soluble alumina content in excess of 35 per cent. Of these, three were between 40 and 45 per cent.

The samples assaying greater than 35 per cent. came from Mt. Kokeby, Toodyay, Dwellingup and New Norcia areas.

**Bentonite.** Though three of the ten clays examined for their bentonitic properties showed strong dye absorption capacities only one, from Kojonup, showed significant swelling properties.

**Beryl.** About a dozen beryl samples were received, four representing commercial parcels, all of which assayed between 11 and 12 per cent. BeO.

Hand specimens originated from the Geraldton district, Windsor and Wydgee stations, Melville and Shaw Crossing.

The samples from Windsor and Wydgee both contained inclusions of columbite and columbite-rutile intergrowths, as much as 5 per cent. of one specimen being made up of these minerals.

A sample from Windsor assayed 13.3 per cent. BeO, with 0.005 per cent. rubidium and 0.04 per cent. cesium.

**Cave Minerals.** An analysis was carried out on the first specimen of taranakite recorded from Western Australia. The mineral is a hydrated basic phosphate of potassium and aluminium and was found in a cave at Mimegarra. Analysis of the purified material gave the following figures:

	Per cent. on dry basis.
Phosphorus pentoxide, P <sub>2</sub> O <sub>5</sub> .....	46.4
Alumina, Al <sub>2</sub> O <sub>3</sub> .....	18.2
Iron oxide, Fe <sub>2</sub> O <sub>3</sub> .....	0.81
Lime, CaO .....	0.10
Magnesia, MgO .....	less than 0.01
Potash, K <sub>2</sub> O .....	4.64
Soda, Na <sub>2</sub> O .....	0.14
Combined water, H <sub>2</sub> O <sup>+</sup> .....	30.4

A paper is being drafted describing the mineralogy of this material and will be submitted for publication in the near future.

**Clay.** There was an increase in interest in clay deposits due probably to the market demand for a high quality kaolin suitable for paper filling and coating. Clay of the required quality does not occur naturally: A product having the necessary fineness, brightness and viscosity can be obtained only by up-grading natural deposits. Because of this demand for prepared products the industry deals chiefly with five or six established vendors throughout the world who tailor products to specific requirements. One such overseas vendor produces three products of increasing quality having the following approximate specifications:

	Grade 1	Grade 2	Grade 3
Brightness—G.E. units .....	84	86	87
Fineness—per cent finer than 2 microns .....	50	80	93

Material of such extreme fineness can be obtained from natural deposits only by some form of elutriation, usually requiring a good supply of water near the deposit to enable at least a preliminary beneficiation.

Test methods vary, particularly as regards the measurement of brightness and viscosity, and the requirements in these respects are best determined by close technical liaison between vendor and consumer.

The only useful work that the Division can do on samples submitted as potential paper clays is firstly to establish its true mineral nature and then determine its content finer than 2 microns and measure the reflectance or brightness of this fine fraction compared with standard magnesium carbonate. If the results are promising the client can then be advised to submit representative samples to established up-grading firms.

Several samples were examined along these lines. Assessment was also made of the potential of the grit fraction as glass sand.

Thirteen clay samples from the Lake Carnegie system were submitted by the Geological Survey for mineralogical and chemical examination. Most were mixtures of kaolin and quartz. None showed a significant boron content, and no geochemical anomalies were evident.

Tests were carried out as in past years to determine the firing properties of clay submitted from many parts of the State. Among these were nine samples from the Port Hedland-Roebourne area taken by the Geological Survey in the course of a survey of clays in that area. Some contained an excessive grit content, others excessive amounts of salt. In one case a high calcite content gave the clay an undesirably low fusion temperature. One sample had marked bloating properties. Two or three gave hard tough briquettes of pleasing color, with satisfactory shrinkage and porosity figures after firing between 1150°C and 1250°C.

Three standard clay samples were kindly donated by Dr. Ralph Grim, of Illinois U.S.A., as reference standards for X-ray diffraction work. The samples were calcium montmorillonite from Cheto Arizona, sodium montmorillonite from Wyoming and illite from Marblehead, Illinois.

**Diatomaceous earth.**—A number of samples were examined mainly to assess their filtering properties after calcination. In one case addition of salt before calcination at 900°C doubled the filtration rate of the same material calcined without addition of salt, the faster rate being slightly better than that obtained using imported commercial filter aid.

A high quality sample from Lake Gngangara had a bulk density of only 10 lb. per c.ft. after calcination at 900°C. Analyses before and after calcination gave the following results:

	Air dry per cent	Calcined per cent
Moisture .....	5.31	...
Loss on ignition .....	16.5	...
Silica, SiO <sub>2</sub> .....	70.4	90.1
Alumina, Al <sub>2</sub> O <sub>3</sub> .....	4.62	5.91
Iron oxide, Fe <sub>2</sub> O <sub>3</sub> .....	1.61	2.06
Titanium oxide, TiO <sub>2</sub> .....	N.D.	0.19
Calcium oxide, CaO .....	a	a
Magnesium oxide, MgO .....	0.20	0.26
Sodium oxide, Na <sub>2</sub> O .....	0.15	0.19
Potassium oxide, K <sub>2</sub> O .....	N.D.	0.24
Sulphur dioxide, SO <sub>2</sub> .....	0.05	0.07
Bulk density .....	lb per c. ft. 21	lb per c. ft. 10

a—less than 0.01  
N.D.—not determined

**Gold.**—The number of samples assayed for gold was much the same as in the previous year and therefore one of the lowest on record.

Most samples assayed on a full pay basis were for clients who preferred fire assay figures to those obtained by atomic absorption, while a number were assayed by conventional means to provide standards for laboratories interested in developing an atomic absorption method for gold.

Only 48 samples of tallings were received from State Batteries, four of which were for umpire assay.

**Iron.**—As would be expected, a wide range of iron minerals were submitted for identification.



Among the more striking were some very odd shaped specimens of goethite pseudomorphs after marcasite from Mooka Station and massive botryoidal hematite (kidney ore) submitted from an unknown location by the Department of Native Welfare.

Titaniferous magnetites are always of interest as potential sources of vanadium and four samples examined during the year showed the following analyses.

Locality	Bolgart per cent	Avon loc. per cent	Morawa per cent	Youanmi per cent
Fe <sub>2</sub> O <sub>3</sub>	67.7	87.5	....	73.9
TiO <sub>2</sub>	16.9	7.62	13.2	15.4
V <sub>2</sub> O <sub>5</sub>	0.57	0.27	1.0	0.88

A magnetic fraction from Shaw River concentrates submitted by State Batteries was found to be mainly martite (hematite replacing magnetite) with some remnant magnetite associated with a little ilmenite, rutile, garnet and euxenite.

Iron ores and dusts from commercial deposits in Western Australia were analysed for uranium and thorium at the request of the Commissioner of Public Health. Uranium ranged from 1 to 3 parts per million and thorium from less than 5 to a maximum of 20 parts per million.

The Division continues to co-operate with other laboratories in examining methods of determination of various elements in iron ore. This work organised in Australia by the Standards Association of Australia on behalf of the International organisation for standardisation is aimed at standardising analytical methods in all countries interested in the production, sale and purchase of iron ore. Amongst the more active participating countries are Australia, Belgium, Canada, Czechoslovakia, France, Germany, India, Italy, Japan, Netherlands, Sweden, United Kingdom, U.S.A. and U.S.S.R.

**Limestone.**—Forty-two samples of carbonate rocks from the North West Division were analysed at the request of the Geological Survey to assess their potential as commercial limestones. Each was analysed for calcium, magnesium, iron, aluminium, silica, manganese, phosphorus and sulphur. Requirements vary widely with end use but general chemical specifications were provided covering the use of such material as a metallurgical flux, for agricultural use and cement manufacture and as raw material for burnt lime.

A sample of shell grit contained calcium oxide equivalent to 91.6 per cent. calcium carbonate. Removal of material finer than 20 mesh (9 per cent. of the sample) resulted in only slight up-grading to 93.1 per cent.

**Nickel.**—The demand for nickel determinations was less than in previous years, though still considerable.

Though Kambalda and Norseman remain the only two localities from which we have recorded gaspeite, the number of recorded occurrences of nickeloan magnesite continues to grow. These now include Kurnalpi (Ni 8.33 per cent.), Scotia (Ni 5.4-16.2), Siberia (Ni 1.45), Norseman (Ni 27.3), Canegrass (Ni 2.95) Eucalyptus (Ni 2.5), Marvel Loch (Ni 2.47), Golden Valley (Ni 2.26), Pyke Hill (Ni 1.1), Widgiemooltha (Ni 6.4) and Yundamindra.

The nickel content of three specimens of chrysoprase from Wingellina ranged from 0.81 to 2.13 per cent. The same species from Gabanintha contained only 0.12 per cent nickel.

A sample of magnetite from the Pilbara assayed 1.27 per cent nickel. The form of occurrence of this unusually high nickel content could not be determined

A rock from the Scotia Nickel Mine containing a green mineral was submitted for examination by the Geological Survey.

A thin section of the green mineral showed mainly isotropic material having cleavage or pseudocleavage (possibly a relic structure) and moderate positive relief.

The X-ray diffraction pattern was that of "crystalline" opal with some extra lines. A garnierite from Noumea gave the basic opal X-ray pattern, combined with serpentine lines, the latter being absent in the case of the Scotia material.

Nickel is removed from both the Noumea and Scotia samples by treatment with hot hydrochloric acid, the residue in both cases giving characteristic opal X-ray patterns.

The identity of hydrous nickel silicates is at present rather nebulous. The mineral examined is possibly a nickel analogue of chrysocolla, that is nickel oxide in a silica gel. D.T.A. patterns show strong similarities to the aluminium and iron silicates, allophane and hisingerite.

A purified sample of the mineral gave the following analysis:

	per cent
Silica, SiO <sub>2</sub>	65.65
Nickel oxide, NiO	20.81
Ferric oxide, Fe <sub>2</sub> O <sub>3</sub>	0.43
Alumina, Al <sub>2</sub> O <sub>3</sub>	0.58
Lime, CaO	0.04
Magnesia, MgO	1.16
Soda, Na <sub>2</sub> O	0.40
Potash, K <sub>2</sub> O	0.04
Lithia, Li <sub>2</sub> O	0.05
Chromium oxide, Cr <sub>2</sub> O <sub>3</sub>	0.10
Zinc oxide, ZnO	0.04
Copper oxide, CuO	1.49
Chloride, Cl	0.66
Moisture, H <sub>2</sub> O <sup>-</sup>	4.19
Combined water, H <sub>2</sub> O <sup>+</sup>	4.26
Manganese oxide, MnO	a
Titanium dioxide, TiO <sub>2</sub>	a
Phosphorus pentoxide, P <sub>2</sub> O <sub>5</sub>	a
Sulphate, SO <sub>4</sub>	a
Carbon dioxide, CO <sub>2</sub>	a
	100.14
less O = Cl	0.15
	99.99

a less than 0.01

Analyst: R. S. Pepper.

**Noble metals.**—Sands from Donnelly River that had been partially described some years ago were subjected to an X-ray fluorescence scan. One sample showed osmium, iridium and ruthenium as major constituents with minor amounts of platinum, rhodium and silver.

A second sample from the same area showed no noble metals, the major elements being tin and zirconium together with a number of rare earths.

Of the 38 samples submitted for platinum assay all but two contained less than 2 grains per ton (approximately 0.13 parts per million). The highest assay was 10 grains per ton.

In all cases, platinum was determined by concentrating the noble metals into a silver prill by fire assaying a charge of 1 assay ton, then dissolving the prill in acid and determining platinum by atomic absorption. Check assays of samples showing less than the limit of detection (2 grains per ton) were carried out after addition of known amounts of platinum. Results were as follows:

Sample	Platinum, Pt		
	In original	added	recovered
		grains per long ton	
1	less than 2	6	5
2	less than 2	24	21
...	less than 2	10	8

**Quartz and glass sands.**—Specimens of quartz received included a black variety from Mukinbudin, pale amethyst crystals from Tom Price, massive material from Londonderry showing veins and striations with microscopic acicular inclusions and high quality chrysoprase from Wingellina.

Only half a dozen samples of silica sand were submitted for testing their suitability as raw material for glass manufacture. All were good quality, SiO<sub>2</sub> figures ranging from 99.0 to 99.9 per cent. with Fe<sub>2</sub>O<sub>3</sub> mainly between 0.01 and 0.03 per cent.

A number of analyses were carried out in connection with work being undertaken by Engineering Chemistry Division on the up-grading of blast furnace slag for potential use in the glass industry.

Rare earths.—The rare earth mineral most commonly examined was monazite. Fourteen shipment parcels were analysed for thorium, total rare earths and in some cases, titanium.

A concentrate from Cooglegong had a percentage composition of 26 monazite, 13 cassiterite, 7 tautouxenite while of three others submitted from the Pilbara one contained 26 per cent. tautouxenite with 58 per cent. monazite.

Good quality specimens of allanite and gadolinite were received for identification from Yandeyarra and Shaw River respectively.

Though a few tons of gadolinite were mined for their beryllium content during the first two decades of the century possibly the best market for both allanite and gadolinite in the small quantities normally available would be as specimen material for both large and small collectors.

Selling prices quoted by overseas firms interested in the sale of mineral specimens vary roughly as follows:—

Allanite \$2 to \$4 per lb depending on size.

Gadolinite \$4 to \$7 per lb depending on size.

One inch fragments of each are offered for sale at between 40 and 75 cents per fragment.

Salt.—A number of salt samples from local sources were analysed to determine their conformity with Food and Drug Regulations for table salt. Various brines were also analysed in connection with the production of this material.

A product resulting from processing a brine by solar evaporation was examined at the request of the Department of Industrial Development to determine its relationship with langbeinite, the double sulphate of magnesium and potassium. Analysis showed it had much the same composition as this double salt.

	Sample per cent	Langbeinite K <sub>2</sub> SO <sub>4</sub> ·2MgSO <sub>4</sub> per cent
Potash, K <sub>2</sub> O	20.6	22.7
Magnesia, MgO	20.1	19.4
Sulphur trioxide, SO <sub>3</sub>	55.5	57.9

Talc.—Two talc samples were examined for conformity with Toilet Preparations Federation specification No. 12. This included confirmation of the mineral as talc by X-ray diffraction, determination of alkalinity, solubility in water and acid, magnesium, lead and arsenic contents, and loss on ignition over two temperature ranges.

The higher of these two ranges specifies loss on ignition between 550°C and 900°C. Fundamental studies of talc (J. Am. Ceramic Socy. 37:126,1954) have shown that maximum loss on ignition is not reached until temperatures between 965°C and 1,000°C. The greater part of this loss is limited to a short temperature range covering less than 100°C and so a reliable, reproducible figure for loss at 900°C is difficult to obtain. For this reason, an ignition loss at 1,000°C would seem a more practical specification than one at 900°C.

A grey talc was received from Mt. Gratwick, a green variety from the vicinity of Caron and one heavily impregnated with iron from Coorow.

Tantalite-Columbite. Twenty-six samples were received during the year, most being sales parcels on which the tantalum, niobium, tin, manganese and titanium contents were required.

Interpretation of such analyses to producers in some cases still poses problems. The difficulty is mainly to explain the existence of a continuous series of minerals from iron manganese tantalate at one end to iron manganese niobate at the other, with virtually an infinite number of combinations in between. Not only does the tantalum-niobium ratio vary but the proportion of iron to manganese also varies independently of the tantalum-niobium figures.

Strict use of the term columbite, for instance, is limited to a mineral in which the molecular proportion of niobium to tantalum is greater than unity. But expressed as a ratio of percentages a mineral becomes columbite when the ratio niobium to tantalum is only 0.51. This further complicates explanations.

High grade tantalum minerals received included a tantalite from Windsor station containing 73 per cent Ta<sub>2</sub>O<sub>5</sub> and a tapiolite from Yinnietharra with a specific gravity of 7.39 and approximately the same percentage of Ta<sub>2</sub>O<sub>5</sub> as the Windsor tantalite.

At the other end of the series, a high grade columbite from Noreena Downs assayed 70 per cent Nb<sub>2</sub>O<sub>5</sub>.

Titanium.—Most mineralogical work under this heading consisted of the qualitative and semi-quantitative assessment of the heavy mineral contents of sands.

Chemical work was mostly in connection with up-grading investigations being carried out by Engineering Chemistry Division. The synthetic products produced and the need to determine the significant elements in their differing oxidation states gave rise to analytical problems. As carbides and nitrides were formed during some of the process, determinations were required also for nitrogen and free and total carbon.

Zinc.—A syenitic type rock from the Mukinbudin area was composed of microcline, plagioclase, magnetite, garnet, augite, hematite and quartz. The magnetite fraction was found to contain 11.1 per cent. zinc, possibly as a zinc-bearing spinel or related mineral occurring as ex-solution lamellae in the magnetite.

Two samples from 13 miles SW of Youanmi were of interest. One was a goethite gossan with cavities lined with hemimorphite, chalcedony and clay, the other a dark brown gossan composed of goethite enclosing black magnetic crystals. These magnetic crystals contained chromium 24.9, iron 34.4, zinc 1.66, manganese 0.59 and cobalt 0.05 per cent, and were believed to be a zincian chromite-magnetite intergrowth.

Specimens of sphalerite, associated with galena, siderite and chlorite were received from Liveringa Station.

Ten samples from the Devonian Mine in the Kimberleys were assayed for zinc and lead.

A sample of sphalerite concentrate from Northampton was found to contain the following trace element contents—gallium 120, indium 50, germanium 160 parts per million. The sphalerite treated commercially for recovery of gallium in the United States contains between 10 and 200 parts per million, averaging about 50 parts per million. The content of indium in zinc minerals from different deposits varies widely but an average value of 25 parts per million in concentrates has been used as a guide for approximating world reserves. The germanium content of sphalerite is generally accepted to range between 100 and 1000 parts per million. The above sample therefore contained normal average figures.

Zircon.—Bench scale investigations were carried out on the removal of iron-bearing coatings on zircon. Such coatings are detrimental to sales prospects and are of considerable significance in a highly competitive market.

The work necessitated the development of methods for the separate determination of iron as a coating or as discrete particles or as inclusions within the zircon itself.

#### Miscellaneous investigations

Cement, Concrete and Aggregates.—Work on aggregates was carried out for Main Roads Department, Public Works Department, Geological Survey, Department of Works and private contractors.

Samples from Main Roads were aggregates mainly from the north of the State for potential use in bridge construction. They were examined petrographically, chemically and physically to assess their compatibility with cement in concrete

structures. About a dozen samples were tested for their possible use in construction of the Yule and Turner bridges, and two were found to be suspect. The suspect samples contained chert and very fine-grained quartz.

A sample of shingle from the Maitland River was petrologically suspect (its variable assemblage of different rock types included some of volcanic origin containing devitrified glass) and was borderline by the chemical potential alkali reactivity test. However, subsequent mortar bar tests showed no expansion after 46 weeks, using a cement of normal alkalinity. This result confirms previous experience that the p.a.r. and petrological examinations are biased towards safety, in that they may condemn a safe aggregate but have not in our experience passed an unsafe one.

Six other mortar bar tests for Main Roads Department using aggregates from the Harding, Fortescue, Robe and Nickol Rivers showed these materials to have no deleterious effects.

Sands from the Ord River, in the Halls Creek Shire, were examined for sizing, mineral composition, organic matter and alkali-reactivity. As regards these factors the sands were satisfactory as fine aggregate except perhaps for a mica content of the order of 2 to 3 per cent. The relevant Australian Specification (A77-1957) states "mica particles although not always structurally weak are liable to cause weakness in concrete when present in excessive quantity."

The Public Works Department submitted six core samples of concrete from the Harvey weir for petrological examination of the aggregate and determination of cement content of the mortar matrix.

Concrete from extensions to the Kununurra school was examined for the presence of anti-slip surfacing normally in the form of crushed corundum. No such coating was found.

A dolomite from Weaber Plains, north of Kununurra, was also tested for the Department as a potential concrete aggregate and found to be non-reactive. Seven samples of crushed rock were submitted in connection with the Gascoyne Irrigation-Rocky Pool project; one of them gave potential alkali reactivity figures of R. 180 and S. 303. The material was a limestone containing calcite and very fine-grained quartz, the latter the obvious source of the soluble silica.

The Geological Survey submitted twelve rocks and five sands in connection with their search for suitable concrete aggregates in the Port Hedland-Roebourne area. All, except one rock, were satisfactory as far as laboratory testing was concerned. The exception was a rock composed of quartz, feldspar, goethite, opal and chalcedony, with a little hornblende.

Two samples of hardened concrete were examined for the Commonwealth Department of Works to determine the original mix. In one case, the original ingredients were not available in which circumstances these determinations become approximate estimates.

Original materials were available in the case of a sand-lime cement mortar submitted by the Department of Local Government. Analyses of these materials and of the hardened mortar suggested an original mix at considerable variance with specification.

In addition to the Government samples described above a limited amount of work was carried out in this field for private individuals and companies.

One such investigation consisted of examination of a sand to test its suitability as fine aggregate in the manufacture of cement bricks. It met requirements as regards sizing, organic matter, and alkali reactivity but was composed mainly of calcite including shell and coral fragments. The consensus regarding the use of such material for the required purpose is that it is in general satisfactory but that quartz sand is preferable if available.

Corrosion.—The Division assists the Water Division in problems associated with corrosion when optical or X-ray techniques are required for identification of corrosion products.

A deposit from the screen of a water bore pump on the Kimberley Research Station was identified as a mixture of hydrous iron oxide and manganese oxide, the latter possibly of bacterial origin. A deposit from the fire tubes of the boiler at Fremantle Technical School was also examined at the request of the Public Works Department and found to consist of ferric sulphate, iron oxide and some free sulphuric acid.

Fine particles submitted by a firm of engineering contractors had caused damage to the hydraulic pump of a crane. Examination showed each particle to be composed of corundum with lesser quartz in a groundmass of mullite. The evidence indicated that these extremely abrasive particles had originated from a manufactured ceramic material.

Fluorescent tubes, after two years in a Government building showed green and white corrosion products on the brass end caps and terminal pins. The deposits were shown to be basic chlorides of copper and zinc suggesting that a zinc chloride solution such as soldering flux had been the cause of damage.

Criminal Investigations.—At the request of Criminal Investigation Branch, in connection with a wilful damage charge, comparison was made of paint flakes and smears on a jemmy with similar material from a burgled safe, and also of paint and stains from various localities in connection with the same case.

Two sets of glass fragments were submitted for comparison in connection with a fatal hit and run traffic accident being investigated by the Police. Thickness, specific gravity, refractive index and X-ray spectroscopy characteristics were the same for both samples indicating a high probability that they came from the same source.

It was thought that a small silvery metallic particle adhering to hair of a shooting victim may have been a bullet fragment. It proved to be aluminium.

An interesting sample submitted by the Criminal Investigation Branch consisted of approximately equal amounts of clay and quartz grains with traces of decomposed feldspar and mica.

The question at issue was whether the material was a rock or not, drilling charges being considerably greater in the case of rock than in the case of clay and sand.

The sample lacked coherency and disintegrated in water and so for digging purposes would logically be regarded as a mixture of clay and sand, not as a rock. However, "A Dictionary of Mining, Mineral and Related Terms", published by the U.S. Bureau of Mines seems to leave scope for legal argument with its definition of rock viz "Strictly, any naturally formed aggregate or mass of mineral matter, whether or not coherent, constituting an essential and appreciable part of the earth's crust. Ordinarily, any consolidated or coherent and relatively hard, naturally formed mass of mineral matter."

#### Dust.

1. Air pollution.—Most of the work under this heading was carried out for Public Health Department as part of their periodic dust sampling programmes in industrial areas. Three hundred and twenty samples from Port Hedland were analysed for iron and manganese and sixty-eight from the Esperance port area were analysed for nickel, iron and sometimes copper. Others included 16 from the vicinity of a lime and cement works for calcium, 14 from the Kwinana area for alumina, 50 from Port Hedland for manganese and 18 dust filters obtained from city sampling points to check emission of lead by motor vehicles.

An investigation was carried out into the origin of dust within the Superannuation Building. A number of samples were taken on the site and most were found to contain a white plastic, calcite and titanium dioxide. These materials had originated from abrasion during cleaning of plastic floor tiles and the dust could be controlled by modified cleaning techniques. A similar problem had been met some time previously in another Government building and had been found to be attributable to the same cause.

2. Health Hazards.—About 90 samples of dust were examined for the presence of free silica or asbestos minerals or both. Most originated from operating mines, quarries or industrial plants.

Determination of free silica was requested on a wide range of materials and over a wide range of concentrations.

Material used for sand blasting on the site of the main dam at Kununurra contained from 28 to 39 per cent free silica.

Free silica was determined on samples of respirable dust taken from quarries working granites and quartzites, with similar determinations on the raw materials and on gross settled dust. The relationship between raw material and dusts was not very close.

Forty-four dusts from two mines operating in the Central Gold Fields were examined optically for the estimation of quartz content, the samples being too small for chemical analysis. Values varied from the lower limit of detection at 1 per cent up to a maximum of 20 per cent.

Eighteen iron ore samples, representing most deposits at present being commercially exploited, were analyzed at the request of the Public Health Department for their uranium and thorium contents. Maximum uranium content was 3 parts per million while thorium gave figures up to 20 parts per million.

Considerable analytical and mineralogical work was carried out for the Public Health Department in connection with their investigation into the possible pathological effects of iron oxide dusts. An iron oxide dust free of any possible interfering impurities was required so that rats could be exposed to such dusts and their effect on lung tissue studied. Dust originating from Mt. Newman ore was found to contain kaolin and up 1 per cent of quartz. In an attempt to obtain purer material a sample of reagent grade oxide was submitted for detailed analysis but showed no improvement as regards purity, assaying silica 1.35, aluminium 0.22, calcium 0.37, lead 0.13 per cent with numerous other metals in trace amounts.

An overseas commercial product which glowed in the dark was submitted as a possible toxic hazard, particularly if used in the manufacture of toys. The material was available in three colours and the inorganic content of all was composed of zinc, strontium and calcium, relative amounts varying with colour. Phosphorescence was due to the sulphides of these elements.

Explosives.—The ten explosives examined were all of the ammonium nitrate type. Work required consisted of the determination of oil absorption and the organic matter content.

The investigation commenced in 1970 into different methods of determining the organic matter in ammonium nitrate prills was concluded during 1971.

The methods compared were the combustion and wet oxidation processes.

The combustion method (BS 4267:1968) determines carbon present in all its forms including carbonates. The wet oxidation process (Anal. Chim. Acta 22:120, 1960) relies on oxidation by dichromate solution and does not measure carbon present as carbonate.

Six samples of prills were analysed by both methods with the results summarised below:—

Sample	Carbon per cent.	
	Combustion	Wet oxidation
1	0.002	0.010
2	0.055	0.006
3	0.026	0.041
4	0.013	0.009
5	0.016	0.010
6	0.029	0.013

There was no significant difference in the reproducibility of the methods. The fact that in some samples the combustion method gave higher figures than wet oxidation and in others the reverse, is in agreement with figures published comparing the methods when applied to other types of material.

Since there are no apparent reasons why dry combustion figures should be more significant than those obtained by wet oxidation it was decided to adopt the quicker dichromate method as routine. However, should the figure closely approach or exceed the critical figure of 0.05 per cent, a check would be run by the more tedious combustion method.

Wet oxidation methods examined all relied on chromic acid oxidation but differed in the determination of the excess dichromate. The most satisfactory method was found to be titration by ferrous ammonium sulphate using barium diphenylamine sulphonate as indicator.

Geochemical Analyses.—In addition to the more usual trace determinations for copper, lead, zinc and nickel there has been a considerable demand for the less commonly determined trace elements such as selenium, boron, fluorine, rubidium, cesium, lithium, tin, tungsten, niobium, tantalum, uranium, thorium, barium, strontium, molybdenum, vanadium, gallium, indium and germanium.

One batch of eighty rock samples from the Geological Survey was assayed for 12 trace elements each, while on a second batch of 230 soil samples titanium, chromium, barium, niobium, manganese, vanadium, molybdenum, and phosphorus were determined.

Lime.—A company seeking an explanation for variable products from different kilns submitted 10 samples of kiln products for examination. Compounds identified included calcite, calcium oxide, calcium hydroxide, anhydrite, quartz and calcium sulphosilicate. Chemical analysis and mineralogical examination enabled calculation of the approximate quantitative composition of the various samples with respect to the above compounds.

The green compound calcium sulpho-silicate has been recognised and identified only in recent years in "sulphate rings" in rotary lime kilns and a paper from these Laboratories on the subject has been accepted for publication.

Metals, Alloys and Spurious Minerals.—No private work has been carried out on metals and alloys as there are now private laboratories available for such analyses.

Three alloys were examined for the Department of the Navy, the most complex being the analysis of a non-ferrous alloy for conformity to BS 1400, AB2-C. This involves determinations of aluminium, iron, nickel, manganese, zinc, copper, tin, lead, silicon and magnesium.

Copper tubing was analysed for copper, phosphorus and arsenic at the request of State Engineering Works and a dross from a newspaper printing room was analysed for antimony, lead and tin for the Public Health Department.

Only four spurious minerals mistaken for natural occurrences were received during the year. Two were slags, one was ferrosilicon and one was ferromanganese.

A speiss was submitted for detailed chemical analysis.

Meteorites.—A chondritic meteorite from Edjudina station was submitted by the Geological Survey for mineralogical and chemical analysis.

The meteorite was composed of well defined chondrules mainly composed of olivine and less orthopyroxene, with scattered aggregates of kamacite and troilite and traces of microcrystalline feldspar in a fine-grained groundmass.

Determination of the unit cell dimensions of the least disordered crystal fragments of olivine extracted from the sample gave figures corresponding to a composition fayalite  $15 \pm 3$  per cent, forsterite  $85 \pm 3$  per cent. Though the available orthopyroxene material was too fine-grained and disordered for single crystal work, a Guinier powder pattern suggested with reservations a compositional range in this case of ferrosilite  $13 \pm 13$  per cent, enstatite  $87 \pm 13$  per cent.

Mineralogically the meteorite would be classified as Group H, type 5, of the classification proposed by Van Schmus and Wood in *Geochimic et Cosmochimica Acta*, 31:747, 1967.

The same meteorite was analysed chemically.

The procedure followed was that developed in the British Museum Department of Mineralogy (Min. Mag. 36:101, 1967) and depends on the reaction of various meteorite phases with dry chlorine. The magnetic and non-magnetic fractions are separately subjected to chlorination and subsequent chemical treatment separates the components into four groups, each of which is then analysed in detail.

The particular sample examined from Edjudina gave the following overall figures, expressed as percentages of the whole sample:

Group 1. Sulphides	5.29
Group 2. Metal	20.4
Group 3. Nickel-rich taenite	0.36
Group 4. Silicates, oxides, phosphates	73.9

Each of the groups were analysed for all constituents, including trace amounts of germanium, gallium, copper and zinc.

A hollow button-type australite, found in the Murrin Murrin area, was donated by Mr. G. Rasmussen.

Though hollow forms are known among various types of tektite, including australites, they are by no means common.

In this sample the posterior surface showed slight flow-swirled marks and small bubble pits. The large central bubble was broken on this surface, where the walls were thinnest, the opening being large relative to the bubble size, and circular. The hot polish of the inner surface of the bubble had been dulled by erosion.

The anterior surface showed the effects of ablation with the development of a few prominent ridges. In one of the valleys a small opening penetrated into the bubble cavity. There was an undulating equatorial zone.

The maximum diameter was 22 mm, depth 11 mm. The bubble volume was 0.85 ml, diameter 12 mm, depth 8 mm. Total weight was 3.74 g and S.G. 2.44.

## WATER DIVISION

### General

The Water Division was able to occupy its newly renovated buildings in April of this year and the improved laboratory layout has increased its operating efficiency.

Unfortunately because of restricted Government expenditure during 1971-1972 the Division has not been able to purchase the equipment it had originally intended and the use of similar equipment in other Divisions has not promoted optimum efficiency.

Since moving into the new building analyses associated with pollution have increased considerably and now constitute about ten per cent of the effective work output. Because of the active participation of our members in the Australasian Corrosion Association, the increased involvement with the Metropolitan Water Board and the Public Works Department in their water treatment programmes and our increasing role in corrosion problems for both Government Departments and the public, our consultative and advisory work, particularly by telephone has increased considerably.

Table 22 indicates the source, number and type of samples received during 1971 and reflects the increasing role of the Division in matters associated with pollution, water treatment and corrosion.

Table 22  
WATER DIVISION

	Agriculture Department	Fisheries and Fauna Department	Medical Department	Metropolitan Water Board	Mines Department	Public		Public Health Department	Public Works Department	Swan River Conservation Board	Other Government Departments		Total
						Free	Pay				Federal	State	
Brine	...	...	...	...	...	...	25	...	...	...	...	3	28
Chemicals for Water Treatment	...	...	...	15	...	...	...	1	...	...	1	...	17
Corrosion	...	...	1	2	1	...	3	1	1	...	...	1	10
Deposit	...	...	2	6	1	1	2	...	12	...	...	...	24
Effluent	...	...	...	...	...	...	19	...	5	6	...	...	31
Water	60	21	8	1,512	513	3	573	29	802	...	9	16	3,546
Water (Fluoridated)	...	...	...	686	...	...	...	...	900	...	...	...	1,536
Water (Swan River)	...	...	...	...	...	...	6	1	...	102	...	...	102
Various	...	...	3	10	1	...	...	...	5	...	3	2	31
	60	22	14	2,231	516	4	628	32	1,725	108	13	22	5,375

Mr. P. Jack attended the Annual Conference of the Australasian Corrosion Association in Melbourne and his co-ordinated visits to associate organisations concerned with corrosion and water analysis and treatment have been and will continue to prove beneficial. He continues as Chairman of the State branch of the Australasian Corrosion Association and two other staff members remain on the committee. Mr. Platell received "the best review paper of the year" award for his paper presented to the Annual Conference of the Australasian Corrosion Association in 1970.

### Public Water Supplies

1. Salinities of the Main Catchment Dams in the Darling Range.—Most of the States public water supplies stem from catchment dams in the Darling Ranges. Of these Mundaring serves the Goldfields-Comprehensive scheme and Wellington serves the Southern-Comprehensive. Due to a series of lower than normal annual rainfalls, coupled with little or no overflow, most of these dams are close to their highest ever salinity values. See Table below of maximum and minimum salinity values, averaged from January to December, for the years since 1960.

	min-imum	(year)	Total Salts parts per million		present 1971
			maxi-imum	(year)	
Canning Dam	170	(1964)	320	(1970 & 1971)	320
Mundaring Weir	150	(1964)	510	(1971)	510
Serpentine Dam	150	(1964)	220	(1970 & 1971)	220
Wellington Dam	170	(1964)	560	(1970)	540

2. Manganese levels in bores serving country town water supplies.—A survey of bores serving country town water supplies showed that manganese is not as uncommon as originally presumed. Although reticulated supplies are not necessarily troublesome because bores with troublesome levels can be blended with other bores feeding the reticulation, manganese has been found in excess of 0.2 parts per million in bores serving the following country centres Derby, Geraldton (Wicherina), Northampton, Eneabba, Bunbury and Kununurra.

3. Lithium levels in miscellaneous waters throughout the State.—If lithium levels in irrigation waters exceed 0.05 parts per million it is likely to cause detrimental effects with citrus trees. Forty-three samples of bore water taken from various sites all over the State showed that lithium toxicity is unlikely to be a significant factor. Most of the samples analysed had a lithium to total

salts ratio lower than that of sea water. Three samples had lithium values between 0.05 and 0.15 parts per million but the salinity of all three samples was in every case more than 4 times the recommended maximum for citrus trees.

4. Iodine levels in water from reticulated town supplies.—A survey of iodine levels in waters serving the metropolitan area and other country centres including Albany, Esperance and Port Hedland was undertaken following a medical inquiry. Iodine levels in water serve only as indicators of possible goitre incidence, the generally accepted level below which goitre is indicated being 0.005 parts per million. At this level water supplies only 5 to 10 per cent. of the minimum daily requirement.

In the metropolitan area the artesian and shallow bores had levels of between 0.01 and 0.02 parts per million while the catchment reservoirs in the hills had levels ranging from less than 0.005 to 0.08 ppm. The catchment areas with less than 0.005 ppm were Wungong and North Dandalup and the catchment with the highest value of 0.08 ppm was Serpentine. Albany bores at 0.007 ppm and Esperance bores at 0.005 ppm were the lowest values for the country centres.

### Water Treatment

1. Clarification.—(a) Officers of this Division have spent considerable time during 1971 in discussion with the responsible engineers from the Metropolitan Water Board. They have also carried out plant trials at the Mirrabooka treatment works and jar tests in the laboratory with many varieties of coagulants and coagulant aids and operating conditions. The primary coagulants tested have included alum, ferric sulphate and chlorinated ferrous sulphate while the coagulant aids have included various forms of activated silica, anionic polyelectrolytes and sodium alginate. All the primary coagulants need an aid for effective clarification and, with a suitable aid and operating conditions, are capable of reaching upflow velocities of the order of 10 feet per hour. Ferric sulphate as such is much more expensive than alum but the use of chlorinated ferrous sulphate appears attractive, provided the price at the treatment plant of ferrous sulphate from Laporte at Australind is satisfactory. The treatment of 10 million gallons of water daily would involve the use of about 1000 tons of ferrous sulphate annually, which is a significant portion of the present quantity being disposed of and causing coloured water problems in the ocean near Bunbury.

The use of ferrous sulphate is not without difficulty as the level of iron and manganese in the final water needs tight control on treatment conditions to keep them at satisfactory levels. Of the

coagulant aids tested sodium alginate has given the best performance. It gives greater upflow velocities than activated silica and, although inferior to the anionic polyelectrolyte in this aspect, does not suffer the proven disadvantage of reducing filter runs. This reduction with filter runs for the anionic polyelectrolyte is not caused by carryover from the clarifier but by a surface effect on the sand particles. Other aspects tested at the treatment plant to optimise performance included aeration efficiency, chlorination dosage levels, pH control and timing and sites of the various additives.

(b) Water treatment plants being operated by the Public Works Department have been visited less frequently during this year but a continuous contact has been maintained with the quality of the treated water and operation problems.

(c) A recommendation for the treatment and design of the water supply to the Mogumber Native Mission was made after an inspection and carrying out jar tests at the site.

2. Fluoridation.—Fluoridation of the Esperance town water supply commenced during 1971. The unfluoridated water already contains 0.4 to 0.5 parts per million of fluoride. Fluoridation of the treated water from the Mirrabooka plant also commenced during 1971. Normally bore water supplying Perth is not fluoridated because most bores already contain the optimum level of 0.6 to 0.8 parts per million of fluoride and are also blended with fluoridated water from the Hills supplies before reaching the consumer.

The exception is Mirrabooka bore water which is fed directly into the reticulation without blending and its level of fluoride is raised to 0.7 to 0.9 parts per million. Water supplies from which regular samples are received now include Albany, Collie, Esperance, Geraldton, Manjimup, Mundaring-Goldfields, Perth and Wellington-Southern. From the regular samples collected and analysed the degree of control at the fluoridation plants is considered satisfactory. The average dosage level is close to that intended but is sometimes marginally below that intended because of breakdown of dosage equipment.

3. Desalination.—Tests from the recently installed pilot plant desalination unit at the Attadale bore indicate that it is performing up to expectations. This unit is composed of weak acid and base exchange resins which are regenerated by low energy heat and this is its first extended trial with a natural water. It is designed specifically for a raw water feed with a total salts level in the range of 1000 to 1500 parts per million which it will reduce to 500 ppm. A comparison of the raw and product water from this unit and a reverse osmosis unit is given in Table 23.

Table 23

### DESALINATED WATER

	Reverse Osmosis			Heat Regenerated Resins		
	Inlet Water	Product Water	Removal	Inlet Water	Product Water	Removal
	parts per million		per cent.	parts per million		per cent.
Total salts	2,900	270	91	1,160	480	59
Sodium, Na	834	93	89	400*	174*	56
Calcium, Ca	39	2	95	18	4	78
Magnesium, Mg	111	3	97	9	<1	+89
Bicarbonate, HCO <sub>3</sub>	2	2	nil	110	61	45
Chloride, Cl	1,540	157	90	536	186	65
Sulphate, SO <sub>4</sub>	230	1	99	102	74	27
Silica, SiO <sub>2</sub>	4	<1	+75	19	19	nil

\* These levels are calculated expressing the Na + K as Na.

The similarity between the two processes is that they both show a preference for removal of magnesium and calcium in that order over sodium and hence during the process of desalination have a greater tendency to soften the water than merely remove the salts.

Reverse Osmosis removes the sulphate almost completely whereas in the Heat Regeneration process sulphate is the least removed of all major ions.

Because of its non ionic nature silica is not removed by the Heat Regeneration process whereas it is with Reverse Osmosis. Tests on the unit will continue during 1972 to ensure that the capacity of the resin and the quality of the product water do not alter.

4. Algal Control with Copper Sulphate.—Continuous dosage of copper sulphate at an intended level equivalent to 0.25 ppm Cu, to the holding reservoirs for South coast bores feeding the softener to the Albany town water supply has been satisfactory in controlling the diatom growth that had previously been causing blockage of the exchange resins. Continuous dosage of holding reservoirs with copper sulphate in the metropolitan area has been less satisfactory. Chlorophyll A levels, which are related to algal population, but not necessarily linearly, have been checked weekly at the troublesome holding reservoirs of Melville, Mt. Eliza and Mt. Yokine. The levels of chlorophyll A have been below 5 micrograms per litre for more than 90 per cent of the time but Melville reservoir has been as high as 20 on one occasion. A comparison of chlorophyll A levels with those of copper in solution show that high chlorophyll A levels have occurred only, but not always, when the copper in solution is less than 0.2 parts per million. Other contributing factors to these uncovered reservoirs include percentage of bore water and related alkalinity and temperature levels together with residence times in the reservoir.

5. Breakpoint Chlorination levels for Metropolitan and Country Water Supplies.—Normally a water supply being fed from underground bores is not chlorinated unless that water has undergone some form of chemical treatment.

Most supplies fed from surface catchment are chlorinated to reduce the bacterial counts to a satisfactory level. Surface reservoirs feeding Perth are chlorinated to breakpoint in order to ensure chlorine residuals as far as the holding reservoirs in the city. The breakpoint demand of these waters is very low at only 1 ppm but during 1971 the water from Canning dam was found to require 1.3 parts per million, a result that was confirmed by practice. Treated water at Mirrabooka requires 3 to 5 ppm for breakpoint chlorination and water from Wellington dam requires 2 to 3 ppm.

### Corrosion

Advice on corrosion is given to Government organisations particularly the mechanical services section of the Public Works Department as well as outside organisations specialising in this field. These outside organisations include water treatment consultants, water boring contractors and water equipment manufacturers. The more important results obtained and advice given include the following:

1. Cooling Waters.—There are several factors which will now make it more important for better control of salinity and inhibitor levels in cooling water. Depending on the level and type of inhibitor being used the recommended maximum salinity level varies up to several thousand parts per million total salts. The Metropolitan Water Board, because of foreseeable water shortages is intending to impose a minimum level for total salts of between 1000 and 1500 parts per million.

Because of the undesirability of disposal problems with hexavalent chromium three separate commercial systems under the control of the Public Works Department using filming amine, zinc organic and dianodic molybdate have been periodically inspected and the results of the inspections together with a study of the inhibitor and total salts levels indicate their comparative worth. The

main criterion has been to study the state of the steel tube plates of the heat exchangers and the cast iron valve bodies in an almost all copper system without the benefit of additional sacrificial anodes.

The filming amine trial did not give good corrosion protection but the lower than recommended inhibitor levels would have influenced this result.

The zinc organic trial gave reasonable protection but this also turned out to be inconclusive. Despite apparent overdosing of the inhibitor, the zinc level, which was the control, was always deficient. This was ultimately traced down to absorption of zinc in the wooden slats of the cooling tower which by a cation exchange mechanism contained approximately 1 per cent of zinc by weight. The net result was a dosage rate of inhibitor at 6 times that recommended and a final zinc level at 1/6 of the recommended indicating more than 95 per cent absorption of the added zinc into the wooden slats.

The dianodic molybdate gave the best protection, the inhibitor levels being maintained at satisfactory levels throughout the trial.

2. Hot Water Systems.—Because of the appreciable failure of certain types of heaters and systems under certain conditions these Laboratories have been involved in frequent advice to the Metropolitan Water Board, the Public Works Department Mechanical Services and the manufacturing and consumer public.

(a) Domestic.—The average life for non-temperature controlled copper storage tank units such as solid fuel and kerosine wick fired, receiving only Hills water is reputedly only of the order of 4 years whereas other temperature controlled units in the same area would be expected to last approximately 10 years. Both types of unit in areas receiving a blend of bore water during part of the year perform satisfactorily with reputed expected life of about 10 years. The troublesome units share the same property of frequently being heated to boiling or near boiling water temperatures.

Chemically the main difference between the waters in the troublesome areas and other areas are:—

- (1) lower pH with consequent increased levels of aggressive carbon dioxide.
- (2) lower level of total salts which should reduce corrosion.
- (3) levels of free and residual chlorine of the order of 0.1 to 0.3 ppm compared with none in the unaffected areas.

Because the water meets all health requirements the manufacturers have been advised to alter their materials of construction. Those alterations which have been approved by us include copper cylinders protected by sacrificial aluminium anodes. Glass lined steel vessels protected by replaceable magnesium anodes appear to be performing satisfactorily but because of poor heat transfer characteristics it is suspected that the steel to glass bond may not be permanent in solid fuel units. Stainless steel units which have been performing satisfactorily after several years use are also not recommended because of expected stress chloride attack.

(b) Commercial.—Buildings serviced by a hot water system in a ring main under mains pressure are also experiencing perforation of copper ring mains within two years. Plans to assess the worth of lime or caustic soda addition and dechlorination did not eventuate during the year but are still under consideration.

3. Pumping Equipment.—When corrosive water has been brought to the surface many types of treatment, including aeration are used to render the water less corrosive. This treatment cannot be carried out in the underground aquifer and if a water is corrosive the pumping equipment must be made of a more corrosion resistant material. The corrosive ingredient in most industrial and domestic waters is dissolved carbon dioxide and it is a specialist job to collect a sample from a borehole without losing part of the dissolved gas.

A sampling bottle suitable for collecting such a sample has been obtained and at least one commercial driller is building a prototype for his own purposes.

Normally a water with less than 50 ppm of dissolved carbon dioxide and no dissolved oxygen present is not considered particularly corrosive and cast iron components can give satisfactory performance. For 50 to 100 ppm of dissolved carbon dioxide bronzes are recommended, but between 100 and 200 ppm stainless steels and high nickel alloys are recommended. Waters at Forrestfield have contained up to 200 ppm of free carbon dioxide and waters at the 100 ppm level have been collected from Morley, Rossmoyne, Jandakot and Wanneroo.

4. Boiler at Northam Regional Hospital.—An inspection was made mainly to assess the cause of failure of the coils in one of the steam generator units but also to advise and make recommendations on all aspects of water treatment at the hospital including steam generators, steam condensates, primary hot water circuits and cooling waters. The failure of the coils was due to a number of factors involving:

- (a) intermittent dosing of the feed water by hand and not by continuous feed until about 8 months after boiler start up. This led to high dissolved oxygen levels.
- (b) malfunctioning of the softener with resultant hard water entry to the boiler.
- (c) inadequate precautions taken to ensure the complete absence of an air space during periods of idleness.

5. Corrosion of Aluminium Roofing.—Corrosion of the aluminium roofing at the iron ore pelletising plant at Port Hedland had been so rapid that within 6 months only half the original 22 gauge roofing material was present as metallic aluminium. The balance had been converted to a brittle adherent corrosion product. The attack was almost entirely from the underside with no significant attack from the top side. The presence of water soluble chlorides and sulphates in the corrosion product without any associated sodium indicated the attack to be from hydrochloric and sulphuric acids. These acids would be evolved during roasting of a sea water wetted ore with fuel oil. The recommendation was for the use of cement asbestos roofing with an acid resistant protective coating on the underside.

6. Aluminium Water Pipe.—A sample of aluminium water pipe of approx. 3/32" thickness and 6" diameter had failed to perforation after transporting water from Mount Tom Price. The water analysis was not abnormal containing less than 0.02 ppm of copper. The only significant property of the water that could have contributed to the rapid corrosion was its temporary calcium hardness level of 162 ppm and its supersaturation with respect to calcium carbonate. The aluminium used was not a clad material but was nevertheless a comparatively pure alloy. An unusual feature of the pitting was that it followed the apparent lines of extrusion formed during the pipe manufacture and it was mostly subsurface attack. No satisfactory recommendation could be made other than to change from aluminium to asbestos cement piping.

7. Etching of Aluminium Roofing.—Aluminium roofing that had been tightly stacked had been wet by sea water and suffered corrosion attack with subsequent staining. Removal of these stains by cleaning with caustic soda and rinsing with water in situ from the Karratha town supply had apparently caused dark and light patches in the aluminium roofing. Examination of the roofing showed that the areas corroded by the sea water were well etched whereas the originally uncorroded surface was only slightly etched by the caustic soda. The reflection of light was related to the severity of the etching and depending on the angle of the sun could be either darker or lighter. The appearance of dark and light patches was in no way attributed to the Karratha water.

#### Pollution.

A number of potential pollution sites are being periodically checked for various types of pollutants which could find their way into surface or underground water catchment areas. These programmes involve various Government Departments including Metropolitan Water Board, Mines, Public Works and Public Health.

1. Swan river survey samples are collected at 3 monthly intervals from 48 sites extending from the Fremantle Traffic Bridge to Walyunga Park at the junction of the Avon and Swan and to the Brookton Road Bridge in the upper reaches of the Canning River. These are primarily analysed for oxygen, nitrogen and phosphorus levels and the analyses do show potential sources of pollution which need policing and further regular control by the Swan River Conservation Board.

2. A survey similar to the above is carried out at the Bunbury estuary at six monthly intervals from 24 sampling points.

3. The holding lakes for the spent liquors from ALCOA were tested for alkalinity and mercury and showed that of the 0.5 ppm of mercury originally present in the imported caustic soda only a portion remains in the effluent which contained 0.01 to 0.02 ppm.

4. Underground and surface samples from 9 sources in the vicinity of the Western Mining effluent disposal in the Rockingham area were examined for ammonia, arsenic, copper, iron and nickel. None of these samples showed abnormal levels that would indicate contamination.

5. Eight bore sites were selected in the metropolitan area to cover a variety of environmental conditions. These conditions included soil nature, type of sewage disposal and whether the area was urban, agricultural or industrial. All the samples were tested for arsenic, copper, chromium, iron, manganese, lead, mercury, zinc, nitrogen fractions, phosphorus, phenol, surfactants and pesticides. The nitrate level in the bore from Spearwood was 123 ppm which was well in excess of the maximum of 45 ppm permitted for a drinking water. Pesticides were detected in some of the samples but the highest values were only 1 to 2 per cent of the allowable quantities in drinking water.

6. The Murray River is being regularly checked at 4 different sites for alkalinity levels in order to obtain average uncontaminated results prior to production from the proposed alumina plant at Pinjarra.

7. Nitrate levels in shallow underground water in the Metropolitan area and at Esperance have increased in some bores so that now there are a number of bores where the nitrate level exceeds the allowable maximum of 45 ppm in a drinking water. This is an aspect that needs regular monitoring as it is not uncommon for this to occur in relatively densely populated urban areas. Of the 14 production bores at Esperance 3 have a history of being above 45 ppm but fortunately these are blended to give a satisfactory reticulated water. Bore 15 rose to a maximum level of 264 ppm in July 1971 and is permanently over 100 ppm. The ammonium nitrogen level at this time was 6.9 ppm. Sites in the metropolitan area where the nitrate level has exceeded 45 ppm include Spearwood, South Fremantle, Attadale, Ardross, Melville and Mt. Pleasant.

8. Phenol levels in surface water catchment are being regularly monitored at Wellington Dam. Spasmodic tests are also carried out on all reservoirs serving the metropolitan area. Restriction of phenol levels is not based on toxicity but on potability associated with chlorination. Some of the phenol levels in the reservoirs from which the metropolitan area draws its supplies have exceeded the recommended maximum of 0.002 ppm. Serpentine Dam has been as high as 0.006 but the 1971 level was 0.003 ppm. These are regarded as natural phenols and there is no evidence that their presence is influencing the quality of the water.



9. Samples of sea water from the ocean adjacent to a gypsum washing plant were tested to predict an effect of the washing water on marine life. If the water did not carry suspended undissolved calcium sulphate that could form an insoluble blanket on the sea bed there was no likelihood of any detrimental effect.

10. The floating pale green scum from a sample of sea water from Geraldton was identified as

*Tricho desmium erythraeum*; a blue green algae quite common in the Indian Ocean and one whose blooms can extend over considerable areas. The dying algae releases a red pigment, frequently colouring the sea red. These blooms have been frequently sighted at Dampier where they have caused taste problems with the water from the desalination unit.

# DIVISION VII

## Annual Report of the Chief Inspector of Explosives for the Year 1971

### *The Under Secretary for Mines,*

In accordance with Section 10 of the Explosives and Dangerous Goods Act 1961-1967 I submit the following report on the work of the Explosives Branch for the year ending 31st December, 1971.

### STAFF

Two junior members of the office staff were transferred to more advanced duties in other Branches of the Department but otherwise there were no changes since last year. All members of the staff are now thoroughly experienced in their duties and responded very well to the demands made by a heavy work programme throughout the year.

### LEGISLATION

No amendment was made to the Act or to the Flammable Liquids Regulations but the Explosives Regulations were amended to prescribe for the labelling of each individual detonator whether plain or electric.

### AUTHORISATION OF EXPLOSIVES

One new explosive was authorised by Du Pont and another application was approved towards the end of the year. It will be gazetted early in 1972. Five Du Pont explosives were removed from the Authorised List since they are no longer produced by the manufacturers.

#### *Authorised*

Class 3—Nitro-Compound, division 1  
Du Pont Seismex ZZ

#### *Authorisations Cancelled*

Class 3—Nitro-Compound

Division 1 Du Pont Gelatin (ZZ)  
Du Pont Gelatin Primer 80 per cent.  
(ZZ)

Division 2 Nitramon WW (ZZ)  
Tovex Regular (ZZ)  
Tovex A6 (ZZ)

### MANUFACTURE OF EXPLOSIVES

Manufacture of Class 2 Nitrate explosives commenced on a small scale within the Woodman Point Reserve and is expected to continue for supply to mining projects in the vicinity of the Metropolitan Area. It is proposed that a Licence to Manufacture

Explosives will be issued in respect of this operation. The two licensed explosives factories at Port Hedland and Kalgoorlie continue to produce authorised mixtures of Nitrate explosives for supply to mining projects in those areas. In all, a total of 6,847 tons of Class 2 Nitrate explosives have been manufactured in licensed factories.

At open cut iron ore mines in the Pilbara, large quantities of Class 2 explosives were manufactured on the mine sites using specially designed mobile units which deliver directly into large boreholes on the blasting site. The magnitude of this on-site manufacture is shown by the production of 12,000 short tons during the year at one mine only. During the latter part of the year Hamersley Iron requested approval to investigate a new formulation for dry mix nitrate explosive and detailed specifications for the proposed mixtures were supplied by the Company. Preliminary testing of samples at Woodman Point indicated that the mixtures would be safe to handle and not unduly sensitive. Approval was therefore given for a three months period of practical tests at the Tom Price site subject to strict adherence to the specifications and the Company supplying a report to indicate the results obtained from the trials. During the testing period the Technical Inspector visited Tom Price and reported favourably on the handling procedures and on the adherence to specifications for the explosive. At the end of the year Hamersley Iron will have completed trials and a report is expected on the results obtained.

Display fireworks are manufactured in two small licensed factories for local displays and during the year both these manufacturers constructed new factory premises to conform with requirements under the Explosives Regulations.

### IMPORTATION AND SUPPLY OF EXPLOSIVES

Six shipments were received from the Melbourne factory to North-West Ports and Woodman Point. There were also two shipments of Du Pont explosives from U.S.A. during the year. Supplies to Kalgoorlie and Woodman Point magazines were made by regular and frequent rail consignments from Melbourne throughout the year. Since the opening of the standard gauge line to Perth, explosives were first consigned to Kewdale but it has now become possible to take them through to Robb Jetty and finally convey them to magazines by a short road conveyance. Ammonium nitrate was supplied in increasing quantities from C.S.B.P. factory at Kwinana and importations from overseas have been reduced. The

attached summary shows the total quantities of all explosives and ammonium nitrate supplied during the year ended 31st December, 1971.

Ammonium Nitrate—	Short Tons
Shipped .....	4,760
Railed .....	.....
Produced in W.A. ....	45,058
<b>Nitro-compound Explosives—</b>	
Shipped .....	1,925
Railed .....	535
	2,460
Marine Blasting Powder (NCN) .....	4
Nitrate Explosives Class 2 .....	565
Primers and Boosters .....	144
	Cases
Safety Fuse .....	1,950
Detonating Fuse .....	12,012
Plain Detonators .....	273
Electric detonators .....	3,140
Oil-Well Explosives .....	4
	Pounds
Blasting Powder .....	5,300
Rifle Powder .....	1,500

#### LICENCES AND INSPECTIONS

The bulk of the explosives brought into Western Australia arrive under authority of a Licence to Import and the explosives are authorised. Small consignments for special purposes can be approved by issue of an Entry Permit. During the year there were 43 Entry Permits granted and in each case a Release Certificate was subsequently issued.

The following licences under the Explosives Regulations were issued and renewed during the year:—

Licences to Manufacture .....	4
Licences to Import .....	6
Licences to Manufacture Blasting Agent .....	94
Licences to Sell Explosives .....	52
Licensed Premises .....	44
Licensed Magazines .....	208
Licences to Convey Explosives .....	77
	485
Total Licences issued .....	485

Inspection was made of stores, magazines and licensed premises in the course of other work connected with flammable liquids and special trips were made to Wyndham, Port Hedland and Geraldton to supervise handling and conveyance of explosives at these northern ports. As a direct result of revised regulations and more inspection there has been a considerable improvement in the general safety and efficiency of road conveyance, and contractors are becoming more aware of their responsibility in conveying large quantities of explosives on public roads.

#### EXPLOSIVES RESERVES

*Woodman Point*—This Reserve continues to be the main distributing centre for all districts south of Meekatharra apart from Kalgoorlie and the eastern mining areas. During the year a small plant was installed to manufacture a prepared nitrate mixture for supply in south west mining areas. It appears that this manufacture in the Reserve will continue and production is likely to be increased in 1972. Road movements both into and out of the Reserve have increased to such an extent that the main gates are now open for most of each day and the staff are kept fully occupied in supervision of the road conveyance. Normal maintenance was carried out on all facilities at the Reserve but no major expenditure was necessary for buildings or other works this year.

*Kalgoorlie Reserve*—The factory established last year is now in full operation supplying nitrate mixture explosive for supply by road conveyance to districts both north and south of Kalgoorlie. Otherwise the Reserve is used for bulk storage of the explosives which are used mainly for mining of gold and nickel and it continues to function with a minimum of expenditure on facilities.

*Other Reserves*—Numerous small Reserves in various parts of the State continue to be vested in the Hon. Minister for Mines but are not actually used for storage of explosives. Those which continue to be used are Port Hedland, Meekatharra, Geraldton, Southern Cross and Manjimup. The Explosives Branch continues to retain control of other Reserves since it is always possible that new mining developments in certain areas could make these facilities necessary for storage of explosives or manufacture of blasting mixtures.

#### EXPLOSIVES DESTROYED

At Woodman Point all surplus samples and explosives received from the Police and other sources were destroyed by the Officer in Charge. As in previous years large quantities of deteriorated material were destroyed by dumping at sea in an approved location beyond the continental shelf. At Port Hedland an inspector supervised the destruction of 182 cases by detonation in January and a further 60 cases at Port Hedland were also destroyed in September by detonation under supervision. Small quantities varying from a few pounds to several cases were destroyed by the inspectors in the course of their normal duties.

#### DISPLAYS OF FIREWORKS

During the year 21 Permits were issued by the Explosives Branch after reference to local control authorities in the areas concerned.

#### ANALYSIS AND TESTING

Heat testing of all nitro-compound explosives was continued at Woodman Point and regular tests were made on the burning time of Safety Fuse. Tests were also made on special samples for velocity of detonation and gap sensitivity as required. Throughout the year samples of ammonium nitrate were analysed for combustible matter to ensure that the established limits were not exceeded. The Government Chemical Laboratories carried out investigations on several different methods of determining organic matter in ammonium nitrate and provided a report from which information was circulated to Explosives Branches in other States.

#### ACCIDENTS WITH EXPLOSIVES

##### *Detonation by Lightning*

On 13th March, 1971 an explosion occurred at a remote location in the north of Western Australia. A report from a seismic survey firm indicated that they had temporarily stored 32 tons of nitro-compound explosives at the location before moving it further out into the Simpson Desert. The explosives were inspected by the owners on the previous day and found to be in good order and condition. On the day of the explosion it was noted that there were severe electrical storms in the area. In the complete absence of any other information or evidence it was assumed that the explosion was caused by lightning.

### *Accident with Detonators*

At Katanning a man lost the sight of one eye and suffered facial injuries while preparing a charge for blasting of deep sewerage mains. He was apparently crimping a detonator on to safety fuse at the open boot of a motor car when the accident occurred and was unable to explain exactly what caused the explosion. It is probable that a whole box of detonators exploded.

### *Detonator found in Rubbish Tip*

A 13 year old boy was flown from Port Hedland to Perth for treatment after an electric detonator exploded in his face. He found the detonator at the rubbish tip and afterwards connected the wires to a six-volt battery at his home. The Explosives Regulations have since been amended to require that all detonators be labelled with the words "Explosive—Detonator—Danger". Similar action has been taken by all other States in an effort to prevent this type of accident.

## FLAMMABLE LIQUIDS REGULATIONS

The Flammable Liquids Regulations have now been in full operation for two years and the inspection staff have become thoroughly experienced in their work. The total number of premises registered and licensed is now about 5,000 and as a direct result of the inspectors' diligence, about 1,250 new licences were issued for premises which had not previously been registered. There have been several hundred licences cancelled, these being mostly in respect of small tank and drum storages where the owners were not prepared to comply with the regulations. After an inspection many of them indicated a willingness to reduce their storage to exempt quantities rather than comply with the necessary regulations for safety in respect of a small storage.

Inspections were made of 1,964 premises storing flammable liquids and in addition the inspectors reported 949 occasions on which proposed storages were discussed and advice was given on application of the regulations. Excellent liaison has been maintained between the inspectors and officers of the Shire Councils and the Fire Brigades in all parts of the State. These authorities welcome the visit of an inspector and are pleased to co-operate by discussing local storage problems.

The general improvement and upgrading of storages is a continuing process as the Oil Companies allocate funds for the necessary alterations. In some cases it has been necessary for them to negotiate for purchase of additional land to comply with separation distances required by the regulations. Improvements made during the year are satisfactory but it is conceded that there are still many old-established storages which have not yet conformed. These are being dealt with progressively and further improvements can be expected in each year.

## ACCIDENTS WITH FLAMMABLE LIQUIDS

### *Fire at Service Station*

At a West Perth Service Station the attendant was filling a petrol container in the rear of a panel van when it burst into flames. The source of ignition was evidently a gas refrigerator which was installed inside the van.

### *Tank Wagon out of Control*

A petrol tank wagon rolled down an inclined driveway at a service station in Palmyra and proceeded uncontrolled across a road median strip and footpath before its course was halted by a large tree near a house. Fortunately there was no fire or spillage of fuel and no person was injured.

### *Starting a Fire with Petrol*

At Meekatharra two boys aged 9 and 10 suffered facial burns when they threw petrol onto the fire while lighting a water heater. Petrol is a dangerous commodity and small containers or bottles should not be left around the home where they can be a source of danger to those who may use them for unorthodox purposes.

### *Lack of Proper Labelling*

#### Case 1—

The Chief Inspector of Shops and Factories reported an accident in which a man was injured while washing machine parts with a solvent in a Belmont factory. Apparently the fire occurred when he lit a cigarette and since the drum of solvent carried no warning of its contents being a flammable liquid he had assumed it was non-flammable. The lack of proper labelling was brought to the attention of the Oil Company who supplied the solvent and prompt action was then taken by the Company to advise all customers using the product. The product concerned will, in future, be adequately labelled with the prescribed warning.

#### Case 2—

Under similar circumstances to those mentioned in Case 1, two men in a Perth electrical workshop suffered burns to the body when flammable vapours from a cleaning solvent was ignited by a nearby welding operation. Once again the cleaning fluid was not properly labelled and action was taken to ensure future supplies will be labelled in accordance with the Regulations.

### *Fire at Tank Depot*

Fire occurred in a tank depot at Dampier when fuel oil was being pumped from a storage tank to rail and road tankers. The Company concerned provided a detailed report which indicated that with prompt use of water spray and foam the fire was under control in about an hour. Investigation by the Company indicated that removal of one pump for repair had placed undue mechanical stress on the remaining pump which resulted in fracture of the fuel line and mechanical failure of the pump. Escaping fuel was ignited by heat and friction of the overheated pump components.

### *Depot Untouched by Factory Fire*

After an extensive fire, which occurred at a furniture factory in Osborne Park, the flammable liquids, stored in a licensed internal depot constructed in accordance with Explosives Branch specifications, were found to be undamaged although there had been intense fire around the depot.

### *Country Depot destroyed by Fire*

An Oil Company depot was destroyed by fire at Kellerberrin. The depot did not comply with the Flammable Liquids Regulations and at the time the fire occurred arrangements were being made with the Company for necessary alterations and improvements to the storage. Although the Company concerned

and the local Police provided full reports of the occurrence, the cause of the fire could not be determined.

#### COMMITTEES, LECTURES AND PUBLICATIONS

##### *Advisory Committee on Transport of Dangerous Goods*

No general meeting of this Committee was held in 1971 but the Model Code for Transport of Dangerous Goods by Road was adopted by the Australian Transport Advisory Council at its meeting in Adelaide in February. The Drafting Sub-Committee held a meeting in Melbourne on 3rd September when special consideration was given to the preparation of information cards and to the details for packaging of dangerous goods.

##### *Australian Port Authorities Association*

The Dangerous Goods Sub-Committee held a meeting in Sydney which was attended by the Harbour Master of the Fremantle Port Authority but the Chief Inspector of Explosives was unable to attend this year.

##### *Committee of Flammable Liquids Statutory Authorities*

The Chief Inspector of Inflammable Liquids in New South Wales invited all other State Authorities to attend a meeting in Sydney for the purpose of preparing a Code for Conveyance in Tank Wagons. The Chief Inspector attended the meetings which were held from 5th to 7th May, 1971. This is the first occasion on which there has been direct discussion on flammable liquids between all Australian States. The business was restricted to preparation of a uniform Code for construction and operation of tank wagons and a draft was prepared for further study by all States. Subsequently the delegates met again from 20th to 22nd October, 1971 in Sydney for consideration of comments received from the oil industry and transport companies. The final amended draft was then prepared for circulation before being printed. Copies should then be available for distribution during 1972.

##### *Port Hedland Port Authority*

During 1971 Port Hedland established its independence from the Harbour and Light Department to become a separate port authority having its own regulations. Under these regulations the Chief Inspector of Explosives is the prescribed authority on handling of explosives at the Port, and acts as adviser to the Port Authority. In this capacity the Chief Inspector visited Port Hedland to attend a meeting which resulted in some further limitations being placed on the handling of explosives within the Port. The importing Companies were represented at the meeting and agreement was reached on quantities which could meet the needs of the mining industry and at the same time make a contribution to greater safety of the town and port facilities.

##### *Information for Primary Producers*

Two short articles for information of farmers and country town dwellers were accepted for publication in the *Journal of Agriculture*. One was "Blasting with Ammonium Nitrate" and the other was "Farm Storage of Fuels" which dealt with safety in storage and the exemptions from licence granted under the Flammable Liquids Regulations.

##### *Training of Shot Firers*

Two courses of lectures and general instruction, each of three days duration, were given to Shot Firers employed by Government Departments. These courses did not constitute a complete training for shot firers but were given with the intention of supplementing the experience of practical men with some information relating to the properties of explosives and recommended safe methods of handling and using explosives. Sixteen men attended each course and all of them showed a keen interest in the work and expressed their satisfaction with the information given.

It has been arranged with Department of Labour that a complete training course for Shot Firers will be conducted under control of the Technical Education Branch during 1972. An examination will be held and those who pass the tests will be issued with a Shot Firer's Permit. It will be clearly understood and endorsed on the Permit that it applies only to places other than mines and that the Permit does not in any way prejudice the Mines Regulations nor will it qualify the holder to use explosives in a mine.

##### *Lecture to Trainee Detectives*

A Technical Officer was requested to repeat the lecture on explosives which was delivered to a similar training class last year.

##### *Plastics Institute of Australia*

A Technical Officer delivered a lecture with the title "Fire Hazards and Prevention" to a meeting held at the University of Western Australia in June, 1971. This meeting was attended by a number of visitors including insurance assessors and Officers of the Fire Brigade.

#### POLICE INVESTIGATIONS

Detectives of the Police Department continue to request assistance from the technical officers of the Branch when investigating causes of fires in industrial premises or in suspected cases of arson. Following one investigation Mr. H. Douglas gave evidence in the Coroner's Court concerning the presence of flammable liquid in the vicinity of a house which had burned.

#### CONCLUSION

The Explosives Branch is well established in its new activities and the small group of new inspectors are now experienced in their work. Co-operation with the public and with all sections of industry continues to be very satisfactory and all members of the staff have shown a keen interest in their duties together with a genuine desire to serve the public to the best of their ability. The Branch also continues to receive good co-operation from the Fire Brigade Officers and from other Government Departments and I would in conclusion express my thanks to all those who have assisted with the work of the Branch.

H. DOUGLAS,  
Acting Chief Inspector of Explosives.

# DIVISION VIII

## Report of Superintendent, Mine Workers' Relief Act, and Chairman, Miners' Phthisis Board 1971

Under Secretary for Mines,

1. I submit for the information of the Honourable Minister for Mines my report of this Branch of the Mines Department for the year, 1971.

### 2. General

The State Public Health Department, under arrangements made with this Department, continued the periodical examination of mine workers throughout the year and mines at Kalgoorlie, Norseman, Widgiemooltha, Marvel Lock, Koolyanobbing, Coolgardie, Mount Magnet, Kumarina, Mount Newman, Mount Tom Price, Marble Bar, Port Hedland, Mount Goldsworthy, Dampier, Lake McLeod, Carnarvon and Morawa were visited by the mobile X-Ray unit.

### 3. Mine Workers' Relief Act

#### 3.1 Total Examinations

The examinations under the Mine Workers' Relief Act during the year totalled 4,265 and compared with 4,281 for the previous year; a decrease of 16. The results of examinations are as follows:—

Normal	3,915
Silicosis early previously normal	15
Silicosis early, previously silicosis early	323
Silicosis advanced, previously normal	.....
Silicosis advanced, previously silicosis early	5
Silicosis advanced, previously silicosis advanced	2
Silico-tuberculosis, previously normal	.....
Silico-tuberculosis, previously silicosis early	.....
Silico-tuberculosis, previously silicosis advanced	.....
Silico-tuberculosis, previously tuberculosis	.....
Tuberculosis, previously normal	1
Asbestosis early, previously normal	.....
Asbestosis early, previously asbestosis early	.....
Asbestosis advanced, previously normal	.....
Asbestosis advanced, previously asbestosis early	.....
Silico-asbestosis early, previously normal	.....

Silico-asbestosis early, previously asbestosis early	.....
Silico-asbestosis early, previously silicosis early	.....
Silico-asbestosis early, previously silico-asbestosis early	4
Silico-asbestosis advanced, previously silico-asbestosis early	.....
Silico-asbestosis advanced, previously silicosis early	.....
Silico-asbestosis plus tuberculosis, previously normal	.....
Silico-asbestosis advanced plus tuberculosis, previously silico-asbestosis early	.....
Total	4,265

The 1971 figures, together with figures for previous years are shown on the table annexed hereto. Graphs are also attached illustrating the trend of examinations since 1940.

#### 3.2 Analyses of Examinations

In explanation of the examination figures, I desire to make the following comments:—

##### 3.2.1 Normal, etc.

These numbered 3,915 or 91.80 per cent. of the men examined and include men having first class lives or suffering from fibrosis only. The figures for the previous year being 3,841 or 89.73 per cent. of the men examined.

##### 3.2.2 Early Silicosis

These numbered 338 of which 15 were new cases and 323 had previously been reported; the figures for 1970 being 424 and 30 respectively. Early silicotics represent 7.93 per cent. of the men examined, the percentage for the previous year was 9.90 per cent.

##### 3.2.3 Advanced Silicosis

There were 7 cases reported all of which advanced from early silicosis. Advanced silicotics represent 0.16 per cent. of the men examined, the percentage for the previous year being 0.14 per cent.

##### 3.2.4 Silicosis plus Tuberculosis

There were no cases reported. This compares with one for 1970.

3.2.5 *Tuberculosis only*

One case was reported compared with three in 1970.

3.2.6 *Asbestosis*

There were no new cases reported.

3.2.7 *Silico Asbestosis*

Four cases were reported of which none were new cases.

4. *Mines Regulation Act*

4.1 *Total Examinations*

Examinations under the Mines Regulation Act totalled 6,418. There was an increase of 40 under this Act in 1971 as compared with 1970.

Of the total of 6,418 examined, 5,989 were new applicants and 429 were re-examinees. In addition, Provisional Certificates were issued to 811 persons in isolated country areas.

4.2 *Analyses of Examinations*

Particulars of examinations are as follows:—

4.2.1 *New Applicants*

Normal	.....	.....	.....	.....	5,982
Silicosis early	.....	.....	.....	.....	2
Silicosis early with tuberculosis	.....	.....	.....	.....	.....
Tuberculosis	.....	.....	.....	.....	1
Other conditions	.....	.....	.....	.....	4
<b>Total</b>	.....	.....	.....	.....	<b>5,989</b>

4.2.2 *Re-examinees*

Normal	.....	.....	.....	.....	.....	428
Silicosis early	.....	.....	.....	.....	.....	.....
Silicosis early with tuberculosis	.....	.....	.....	.....	.....	.....
Tuberculosis	.....	.....	.....	.....	.....	1
Other conditions	.....	.....	.....	.....	.....	.....
<b>Total</b>	.....	.....	.....	.....	.....	<b>429</b>

These men had previously been examined and some were in the industry prior to this examination.

4.3 *Health Certificates Issued to New Applicants and Re-examinees*

The following health certificates were issued under the Mines Regulation Act:—

Initial Certificates (Form 2)	.....	.....	.....	.....	6,404
Temporary Rejection Certificates (Form 3)	.....	.....	.....	.....	.....
Rejection Certificates (Form 4)	.....	.....	.....	.....	8
Re-admission Certificates (Form 5)	.....	.....	.....	.....	6
Special Certificate (Form 9)	.....	.....	.....	.....	.....
<b>Total</b>	.....	.....	.....	.....	<b>6,418</b>

5. *Miners' Phthisis Act*

The amount of compensation paid during the year was \$9,712 compared with \$9,462 for the previous year.

The number of beneficiaries under the Act as on 31/12/1971 was 42 being 3 ex-miners and 39 widows.

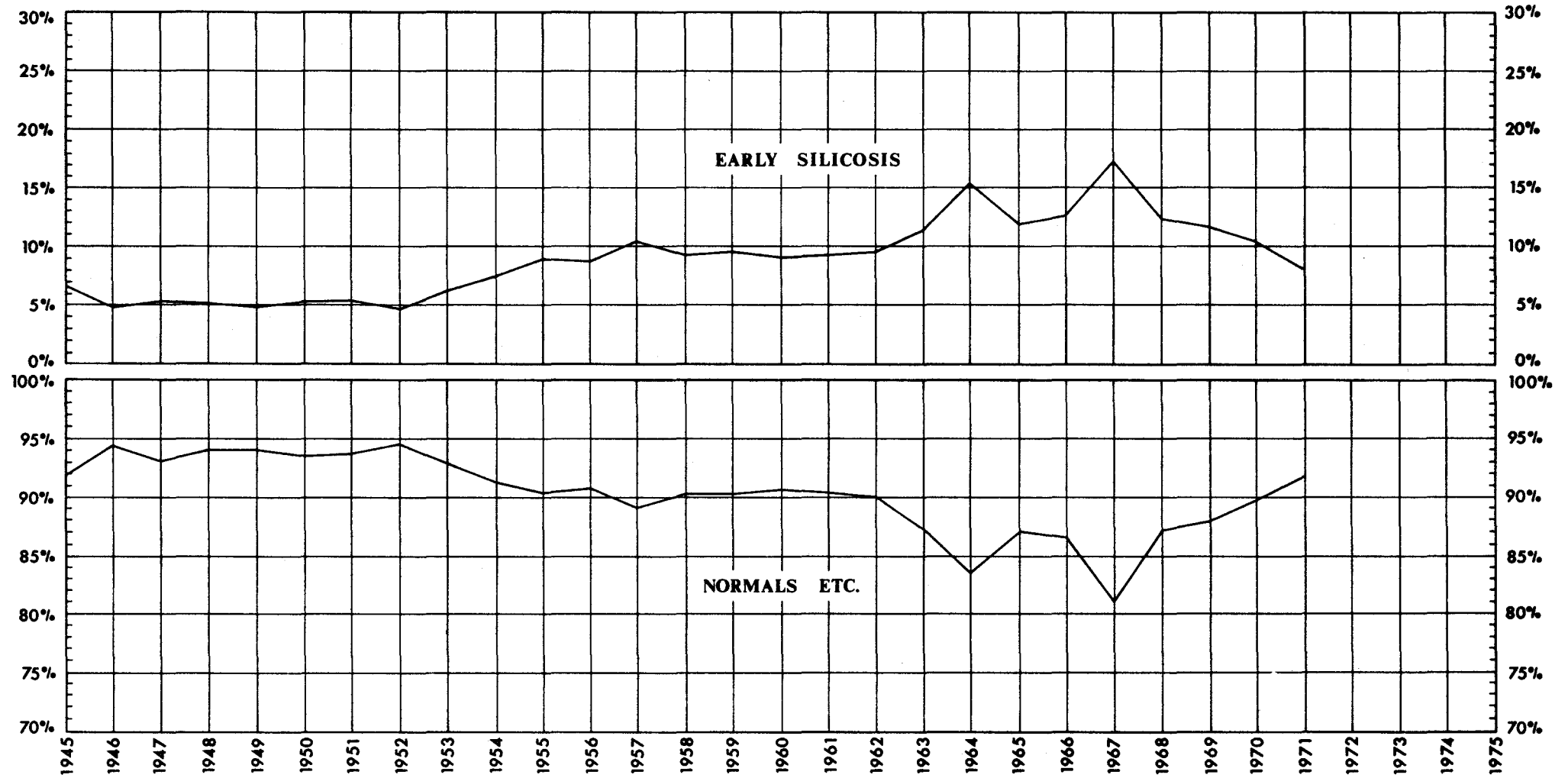
6. *Administrative*

There were no administrative changes during the year.

A. L. DAY,  
Superintendent, Mine Workers Relief Act  
and  
Chairman, Miners' Phthisis Board.

# PERIODICAL EXAMINATION OF MINE WORKERS GRAPH No 1

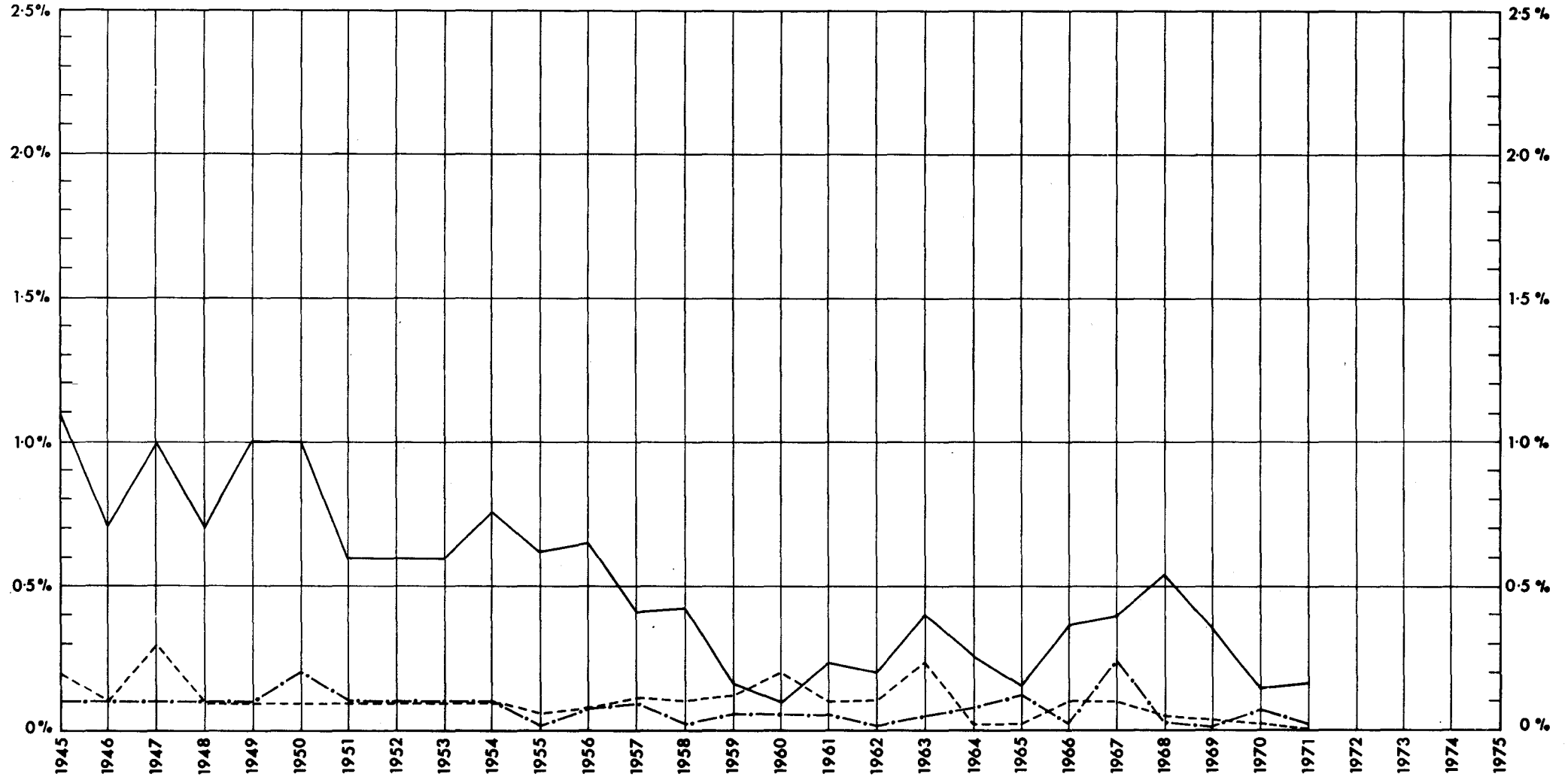
SHOWING PERCENTAGES OF NORMALS AND EARLY SILICOTICS FROM 1945 ONWARDS





# PERIODICAL EXAMINATION OF MINE WORKERS GRAPH N<sup>o</sup>2

SHOWING PERCENTAGES OF SILICOSIS ADVANCED, SILICOSIS PLUS TUBERCULOSIS AND TUBERCULOSIS ONLY, FROM 1945 ONWARDS



SILICOSIS ADVANCED ——— SILICOSIS PLUS TUBERCULOSIS - - - - - TUBERCULOSIS ONLY - · - · - ·

TABLE SHOWING RESULTS OF PERIODICAL EXAMINATION OF MINE WORKERS FROM INCEPTION OF EXAMINATIONS (1925).

Year	Normal		Silicosis Early		Silicosis Advanced		Silicosis plus Tuberculosis			Tuberculosis Only		Asbestosis							Total	Per Cent.	Total															
	Total	Per Cent.	Previously reported as Normal etc.	Previously reported as Silicosis Early	Total	Per Cent.	Previously reported as Normal etc.	Previously reported as Silicosis Early	Previously reported as Silicosis Advanced	Total	Per Cent.	Total	Per Cent.	Asbestosis early previously normal	Asbestosis early previously asbestosis early	Asbestosis advanced previously normal	Asbestosis advanced previously asbestosis early	Asbestosis plus tuberculos previously normal				Asbestosis plus tuberculos previously asbestosis	Total	Per Cent.												
1925	3,239	80.5	....	....	459	11.4	....	....	....	183	4.5	....	....	....	131	3.3	11	0.3	....	....	....	....	....	....	....	....	....	....	....	....	....	....	....	4,023		
1926	2,977	85.5	59	308	362	10.4	....	16	85	93	2.5	39	27	62	123	3.4	10	0.3	....	....	....	....	....	....	....	....	....	....	....	....	....	....	....	3,728		
1927	2,977	85.5	59	308	362	10.4	....	16	85	93	2.5	39	27	62	123	3.4	10	0.3	....	....	....	....	....	....	....	....	....	....	....	....	....	....	....	3,483		
1928	2,120	81.9	102	224	326	12.6	....	34	60	94	3.6	8	14	10	42	1.2	4	0.1	....	....	....	....	....	....	....	....	....	....	....	....	....	....	....	2,588		
1929	2,785	81.9	136	247	383	11.3	....	22	43	67	2.0	8	60	46	114	3.3	50	1.5	....	....	....	....	....	....	....	....	....	....	....	....	....	....	....	3,399		
1930	2,530	84.0	94	252	346	11.5	....	18	35	53	1.8	4	35	19	58	1.9	25	.8	....	....	....	....	....	....	....	....	....	....	....	....	....	....	....	3,012		
1931	3,835	89.5	35	338	373	8.7	....	6	47	53	1.2	3	9	4	16	.4	8	.2	....	....	....	....	....	....	....	....	....	....	....	....	....	....	....	4,285		
1932	2,920	86.5	57	322	379	11.2	....	1	15	24	1.8	2	9	4	15	.4	3	.1	....	....	....	....	....	....	....	....	....	....	....	....	....	....	....	3,377		
1933	5,140	92.4	64	315	369	6.6	....	1	24	44	1.8	7	6	6	37	.7	6	.1	....	....	....	....	....	....	....	....	....	....	....	....	....	....	....	4,808		
1934	4,437	92.3	35	303	338	7.0	....	1	24	2	.6	....	....	....	12	.2	5	.1	....	....	....	....	....	....	....	....	....	....	....	....	....	....	....	5,563		
1935	6,972	94.7	29	323	352	4.8	....	1	15	4	.3	....	....	....	5	.1	2	.0	....	....	....	....	....	....	....	....	....	....	....	....	....	....	....	4,808		
1936	7,487	95.4	15	319	334	4.3	....	1	14	4	.2	....	....	....	11	.1	8	.1	....	....	....	....	....	....	....	....	....	....	....	....	....	....	....	7,883		
1937	6,833	95.7	13	266	279	3.9	....	....	15	2	.2	....	....	....	11	.1	2	.0	....	....	....	....	....	....	....	....	....	....	....	....	....	....	....	7,852		
1938	6,670	95.6	18	264	282	4.0	....	....	7	3	.1	....	....	....	10	.1	3	.0	....	....	....	....	....	....	....	....	....	....	....	....	....	....	....	7,141		
1939	7,023	96.2	12	245	257	3.5	....	....	10	1	.2	....	....	....	11	.2	2	.0	....	....	....	....	....	....	....	....	....	....	....	....	....	....	....	6,975		
1940	6,840	95.8	32	248	280	3.9	....	....	11	3	.2	....	....	....	4	.0	4	.0	....	....	....	....	....	....	....	....	....	....	....	....	....	....	....	7,299		
1941	5,469	93.9	61	264	325	5.6	....	....	20	5	.4	....	....	....	....	....	....	....	....	....	....	....	....	....	....	....	....	....	....	....	....	....	....	7,141		
1942	3,932	91.5	63	262	325	7.6	....	....	25	7	.7	....	....	....	2	.0	3	.1	....	....	....	....	....	....	....	....	....	....	....	....	....	....	....	5,824		
1943	4,079	91.5	70	270	340	7.5	....	....	21	14	.8	....	....	....	5	.1	4	.1	....	....	....	....	....	....	....	....	....	....	....	....	....	....	....	4,298		
1944	3,071	92.1	54	166	220	6.6	....	....	26	10	.6	....	....	....	5	.2	6	.1	....	....	....	....	....	....	....	....	....	....	....	....	....	....	....	4,468		
1945	5,294	94.4	89	172	261	4.7	....	....	36	2	.7	....	....	....	6	.1	2	.0	....	....	....	....	....	....	....	....	....	....	....	....	....	....	....	3,334		
1946	6,021	93.3	101	237	338	5.2	....	....	49	9	.5	....	....	....	25	.3	8	.1	....	....	....	....	....	....	....	....	....	....	....	....	....	....	....	5,606		
1947	4,827	94.0	24	239	263	5.1	....	....	18	17	.7	....	....	....	4	.1	5	.1	....	....	....	....	....	....	....	....	....	....	....	....	....	....	....	6,450		
1948	5,162	94.0	24	239	263	4.8	....	....	20	31	1.0	....	....	....	6	.1	7	.1	....	....	....	....	....	....	....	....	....	....	....	....	....	....	....	5,134		
1949	5,077	93.6	14	269	283	5.2	....	....	14	41	1.0	....	....	....	3	.1	8	.2	....	....	....	....	....	....	....	....	....	....	....	....	....	....	....	5,489		
1950	4,642	93.9	13	248	261	5.3	....	....	9	20	.6	....	....	....	6	.1	4	.1	....	....	....	....	....	....	....	....	....	....	....	....	....	....	....	....	5,426	
1951	5,073	94.6	8	234	242	4.5	....	....	4	31	.6	....	....	....	2	.1	7	.1	....	....	....	....	....	....	....	....	....	....	....	....	....	....	....	....	4,942	
1952	4,474	93.03	74	225	299	6.22	....	....	8	24	.6	....	....	....	2	.1	2	.1	....	....	....	....	....	....	....	....	....	....	....	....	....	....	....	....	5,359	
1953	5,142	91.33	154	275	429	7.62	....	....	22	21	.43	....	....	....	9	.1	7	.1	....	....	....	....	....	....	....	....	....	....	....	....	....	....	....	....	4,809	
1954	4,559	90.40	63	386	449	8.90	....	....	9	22	.31	....	....	....	3	.06	1	.02	....	....	....	....	....	....	....	....	....	....	....	....	....	....	....	....	5,830	
1955	4,600	90.78	25	401	426	8.41	....	....	8	25	.33	....	....	....	4	.08	4	.08	....	....	....	....	....	....	....	....	....	....	....	....	....	....	....	....	5,043	
1956	3,925	89.08	30	424	454	10.30	....	....	8	10	.41	....	....	....	5	.12	4	.09	....	....	....	....	....	....	....	....	....	....	....	....	....	....	....	....	5,067	
1957	5,154	90.20	46	483	529	9.26	....	....	15	9	.42	....	....	....	6	.10	1	.02	....	....	....	....	....	....	....	....	....	....	....	....	....	....	....	....	4,406	
1958	5,242	90.10	66	485	551	9.47	....	....	9	....	.15	....	....	....	7	.12	3	.05	....	....	....	....	....	....	....	....	....	....	....	....	....	....	....	....	5,714	
1959	5,214	90.54	50	473	523	9.08	....	....	5	....	.09	....	....	....	11	.19	3	.05	....	....	....	....	....	....	....	....	....	....	....	....	....	....	....	....	5,818	
1960	5,188	90.18	54	479	533	9.26	....	....	13	....	.23	....	....	....	5	.09	3	.05	....	....	....	....	....	....	....	....	....	....	....	....	....	....	....	....	5,759	
1961	5,183	89.98	50	499	549	9.53	....	....	10	....	.19	....	....	....	6	.10	1	.02	....	....	....	....	....	....	....	....	....	....	....	....	....	....	....	....	5,753	
1962	4,795	87.21	188	451	639	11.62	....	....	22	....	.40	....	....	....	13	.24	3	.05	....	....	....	....	....	....	....	....	....	....	....	....	....	....	....	....	5,760	
1963	3,484	83.85	84	561	625	15.04	....	....	9	....	.24	....	....	....	1	.02	2	.05	....	....	....	....	....	....	....	....	....	....	....	....	....	....	....	....	5,498	
1964	3,770	87.89	53	459	512	11.87	....	....	6	....	.14	....	....	....	1	.02	5	.12	....	....	....	....	....	....	....	....	....	....	....	....	....	....	....	....	4,155	
1965	3,411	86.56	26	469	495	12.56	....	....	14	....	.36	....	....	....	4	.10	1	.02	....	....	....	....	....	....	....	....	....	....	....	....	....	....	....	....	4,814	
1966	1,644	81.03	19	332	351	17.30	....	....	7	....	.39	....	....	....	2	.10	5	.24	....	....	....	....	....	....	....	....	....	....	....	....	....	....	....	....	3,941	
1967	3,364	86.93	39	431	470	12.14	....	....	18	....	.54	....	....	....	2	.05	1	.03	....	....	....	....	....	....	....	....	....	....	....	....	....	....	....	....	2,029	
1968	3,406	87.77	36	412	448	11.55	....	....	13	....	.36	....	....	....	1	.03	1	.01	....	....	....	....	....	....	....	....	....	....	....	....	....	....	....	....	3,870	
1969	3,841	89.73	30	400	430	10.04	....	....	6	....	.14	....	....	....	1	.02	3	.07	....	....	....	....	....	....	....	....	....	....	....	....	....	....	....	....	3,581	
1970	3,915	91.80	15	327	342	8.02	....	....	5	....	.16	....	....	....	....	....	1	.02	....	....	....	....	....	....	....	....	....	....	....	....	....	....	....	....	4,265	
1971																																				

Segregation of asbestosis diagnoses commenced in 1959

# MINING STATISTICS

## to 31st December, 1971

•

### *Table of Contents*

•

	Page
Table I.—Tonnage of Ore Treated and Yield of Gold and Silver, in fine ounces, reported to the Mines Department, from operating mines during 1971, and Total Production recorded to 31st December, 1971, from those mines	172
Table II.—Total Alluvial, Dotted and Specimen Gold, Tonnage of Ore Treated, Yield of Gold and Silver therefrom, reported to Mines Department from each respective Goldfield and District during 1971	178
Table III.—Total Production of Alluvial, Dotted and Specimen Gold, Tonnage of Ore Treated, Yield of Gold and Silver therefrom, since inception to 31st December, 1971	179
Table IV.—Total Output of Gold Bullion, Concentrates, etc., entered for Export, and received at Perth Branch of the Royal Mint from 1st January, 1886	180

#### MINERALS OTHER THAN GOLD

Table V.—Quantity and Value of Minerals, other than Gold, as reported to the Mines Department during 1971	181
Table VI.—Total Mineral output of Western Australia, showing for each mineral, the progressive quantity produced and value thereof as reported to the Mines Department to 31st December, 1971	186
Table VII.—Showing average number of Men Employed above and underground in the larger mining companies operating in Western Australia during the Years 1970 and 1971	188

**TABLE I**

**PRODUCTION OF GOLD AND SILVER AS REPORTED TO THE MINES DEPARTMENT DURING 1970.**

(For details concerning Mines and Centres not listed see Annual Report for 1966 or previous Reports.)

(Note.—Lease numbers in brackets indicate that the holding was voided during the year.)

(Note.—\* Denotes mainly derived from treatment of tailings. † Denotes mainly derived from Lead Ore. ‡ Denotes mainly derived from Copper Ore. § Concentrates.)

Mining Centre	Number of Lease	Registered Name of Company or Lease	Total for 1971					Total Production				
			Alluvial	Dollied and Specimens	Ore treated	Gold therefrom	Silver	Alluvial	Dollied and Specimens	Ore treated	Gold therefrom	Silver
			Fine ozs.	Fine ozs.	Tons (2,240 lb.)	Fine ozs.	Fine ozs.	Fine ozs.	Fine ozs.	Tons (2,240 lb.)	Fine ozs.	Fine ozs.

**Pilbara Goldfield.**

**MARBLE BAR DISTRICT.**

172	Bamboo Creek	G.M.L. 1118	Kitchener	.....	154.00	56.69	.....	.....	1,135.50	1,469.55	3.53
		1203	Mt. Prophecy	.....	388.00	84.66	2.98	.....	4,698.55	2,442.43	113.70
	North Pole	1254	Normay	.....	105.00	26.07	.....	.....	105.00	26.07	.....
			State Battery, Marble Bar	.....	.....	*135.10	10.57	.....	12.00	*14,680.52	475.35

**Nullagine District**

Middle Creek	231L, etc.	Metramar Minerals Limited	.....	13.00	3.75	.....	.....	.....	13.00	3.75	.....
		Prior to transfer to present holders	.....	.....	.....	.....	.....	.....	63,173.48	38,183.23	10.99

**West Pilbara Goldfield**

Yule River	M.C. 572WP	F. R. Sack	.....	19.71	.....	§25.32	.....	19.71	.....	§62.28	.....
------------	------------	------------	-------	-------	-------	--------	-------	-------	-------	--------	-------

**Peak Hill Goldfield.**

Peak Hill	.....	Sundry Claims	.....	20.23	.....	.....	.....	61.51	430.45	35,365.35	9,030.99	5.35
-----------	-------	---------------	-------	-------	-------	-------	-------	-------	--------	-----------	----------	------

**East Murchison Goldfield.**

**LAWLERS DISTRICT.**

Lawlers	G.M.L. 1400	Waroonga	.....	19.30	.....	.....	.....	19.30	.....	.....	.....
---------	-------------	----------	-------	-------	-------	-------	-------	-------	-------	-------	-------

**BLACK RANGE DISTRICT.**

Barrambie	G.M.L. 1117B	Scheelite Leases	.....	87.00	16.77	.....	.....	.....	1,527.00	949.39	19.60
-----------	--------------	------------------	-------	-------	-------	-------	-------	-------	----------	--------	-------

### Murchison Goldfield.

#### CUE DISTRICT.

Cuddingwarra		Sundry Claims			18-00	4-84		18-46	384-38	10,538-39	5,766-04	18-42
--------------	--	---------------	--	--	-------	------	--	-------	--------	-----------	----------	-------

#### MEEKATHARRA DISTRICT.

Meekatharra	G.M.L. 2015N 2062N	Haveluck			3,652-00	208-50				6,883-00	450-40	
		Haveluck West			1,638-00	106-97				1,638-00	106-97	
		Sundry Claims		38-81				279-84	1,392-22	32,599-46	11,760-85	13-10
		(L.T.T. 2/69 (1709H) A. Cella)					4-26				4-26	

#### MOUNT MAGNET DISTRICT.

Lennonville		Sundry Claims			68-50	2-50		26-00	116-97	15,624-27	6,067-50	11-07
Mt. Magnet	G.M.L. (1673M, 1238M, etc.)	Don			4-25	3-54				20-00	4-66	
		Hill 50 Gold Mine N.L.			58,404-00	14,207-84	1,174-35			3,010,623-40	1,307,795-02	65,588-40
		Sundry Claims			18-50	33-06		157-95	2,629-26	62,257-67	30,314-72	29-52

#### YALGOO GOLDFIELD.

Goodingnow	G.M.L. 1063 1243	Ark			44-00	11-40			12-49	2,408-50	1,968-92	
		Threybit			30-00	5-32				502-00	29-31	

### Mt. Margaret Goldfield.

#### MT. MORGANS DISTRICT.

Linden	G.M.L. 576F	Olympic			35-00	4-95				35-00	4-95	
--------	-------------	---------	--	--	-------	------	--	--	--	-------	------	--

#### MOUNT MALCOLM DISTRICT.

Diorite	G.M.L. (1908C 1905C)	Jasper Hills			87-75	32-76				127-75	39-52	
		King of the Hills		14-83					14-83			
Lake Darlot		Sundry Claims			188-00	46-18		129-92	914-83	13,032-87	7,019-26	45-18
Leonora	G.M.L. 1897C 1906C	Bon Boo			471-25	157-49				1,138-55	551-46	
		Sons of Gwalia			111-75	57-03				111-75	57-03	
		Sundry Claims			50-75	2-23		37-73	377-26	23,835-95	13,059-55	26-77
Wilson's Patch		Sundry Claims			33-00	14-99		4-68	54-46	1,799-16	1,470-89	1-12
		State Battery, Leonora				*408-29	7-54			91-00	*685-31	31-88

### North Coolgardie Goldfield.

#### MENZIES DISTRICT.

Menzies	G.M.L. 5816Z	Black Jack			72-75	7-98				72-75	7-98	
Mt. Ida	5537Z, etc.	Lake View & Star Ltd.				8-85				100-50	50-03	3-22
		Prior to transfer to present holders							40-77	487,579-36	248,250-96	8,505-69

Table I.—Production of Gold and Silver from all sources, etc.—continued.

Mining Centre	Number of Lease	Registered Name of Company or Lease	Total for 1970					Total Production				
			Alluvial	Dollied and Specimens	Ore treated	Gold therefrom	Silver	Alluvial	Dollied and Specimens	Ore treated	Gold therefrom	Silver
			Fine ozs.	Fine ozs.	Tons (2,240 lb.)	Fine ozs.	Fine ozs.	Fine ozs.	Fine ozs.	Tons (2,240 lb.)	Fine ozs.	Fine ozs.
<b>ULARRING DISTRICT.</b>												
Mulline		Sundry Claims			26.75	11.10		10.82	296.42	12,282.39	10,019.37	1.14
<b>YERILLA DISTRICT.</b>												
Yarri	G.M.L. (1347R) 1126R, etc.	Dawn			8.00	1.39				198.50	29.02	
		Porphyry (1939) G.M. N.L.			712.00	73.05				68,005.00	10,008.26	
		Prior to transfer to present holders								30,344.50	5,448.82	507.51
		Sundry Claims			46.00	7.43		.87	5.93	18,428.05	6,399.83	1.40
<b>Broad Arrow Goldfield.</b>												
Bardoc		Sundry Claims			450.00	5.62		54.95	1,218.09	18,981.18	8,589.00	
Broad Arrow	G.M.L. 2346W 2357W	Sunday Eve			52.25	59.56				195.75	248.27	
		V.M.P.			40.00	25.69				40.00	25.69	
		Sundry Claims			1,750.50	51.21		1,008.56	3,166.58	40,950.15	17,821.78	1.42
Grants Patch	2278W	Prince of Wales		1.99					1.99	1,531.00	2,186.61	56.51
		Sundry Claims		3.11			4.42	356.66	7,829.62	3,402.86	4.28	
Ora Banda		Sundry Claims			37.50	18.02			467.18	17,501.05	5,246.39	
Paddington	2339W 2298W	Paddington Consuls South			77.00	50.97				285.00	163.37	
		Rona Lucille			218.50	40.98				1,162.25	855.21	17.97
Riches Find	2358W	Pole			96.00	19.53				96.00	19.53	
<b>North-East Coolgardie Goldfield.</b>												
<b>KANOWNA DISTRICT.</b>												
Gindalbie	G.M.L. 1594X	Binti Binti			23.50	2.55				43.00	7.46	
		Sundry Claims			44.75	4.14			716.52	5,924.02	3,319.69	.01
Kalpini	1591X 1599X	Bank of Kalpini			3,021.00	225.56				15,924.00	1,507.48	
		Kalpini Main Lode			278.25	29.26				278.25	29.26	
Kanowna	1586X 1585X	Kanowna Red Hill			181.00	13.64				10,047.75	1,486.91	1.94
		New Kanowna			187.25	27.67				309.25	194.46	
		Sundry Claims			19.75	4.12		125.32	2,169.07	28,881.57	12,310.52	1.71

**East Coolgardie Goldfield.**  
**EAST COOLGARDIE DISTRICT.**

Boorara	G.M.L. 6671E	Waterfall North	141.00	121.35				141.00	121.35	
Boulder	5345E, etc.	Gold Mines of Kalgoorlie (Aust.) Ltd.	137,580.00	34,603.66	26,987.92		849.95	6,286,011.75	1,591,835.64	494,639.03
	5780E, etc.	Prior to transfer to present holders						15,916,923.07	6,416,710.17	819,123.27
	5708E, etc.	Great Boulder Gold Mines Ltd.		357.50	129.14		1.53	16,772,306.97	7,054,763.33	1,885,164.36
		Lake View & Star Ltd.	387,244.00	92,299.15	11,298.69			22,331,478.30	6,226,406.10	701,091.28
		Prior to transfer to present holders					8.49	15,792,500.38	9,149,223.80	1,348,055.82
	5431E, etc.	North Kalgurli (1912) Ltd.	234,701.00	44,227.45	22,497.41		127.55	9,500,795.24	2,339,900.14	696,273.39
	5405E, etc.	North Kalgurli (1912) Ltd. (Croesus Pty. Group)								
		Prior to transfer to present holders					43.99	51.20	90,159.00	19,261.22
								4,018,629.01	2,815,959.95	97,625.03
Hampton Plains	P.P.L. 277, Loc. 50	Lake View & Star Ltd. (Pernatty)	2,468.50	402.05				27,539.00	2,175.87	
		Prior to transfer to present holders						14,868.75	1,445.70	2.06
	P.P.L. 175A, Loc. 48	S. Shackleton	5.16				5.16	503.75	91.94	.27
Kalgoorlie	G.M.L. 6563E, etc.	Gold Mines of Kalgoorlie (Aust.) Limited (Mt. Charlotte)	688,013.00	100,863.00				3,678,019.00	514,778.05	
		Prior to transfer to present holders					5.72	85,723.60	18,167.21	171.56
	6694E	Inkerman	33.00	29.77				33.00	29.77	
	6091E	Lesanben	33.25	45.48			251.79	1,479.60	1,077.57	3.88
	6485E	Maritana Hill	89.75	2.57				4,679.50	562.68	
	6615E	Middle Hannans	207.06	368.63			207.06	2,309.00	493.44	
	6639E	Old Hincheliffe	112.00	24.66				1,428.75	172.82	
		Sundry Claims	8.50	4.22		232.41	1,127.64	64,022.87	23,497.08	.20
Wombola	5497E, 5500E	Daisy Leases	702.50	1,592.22				25,289.95	24,197.20	884.76
	5497E	Daisy						6,282.25	5,031.93	
	5500E	Happy-Go-Lucky						2,075.25	1,675.85	
	6698E	Eastern Return	387.75	19.89				387.75	19.89	
	5689E, etc.	Haoma Leases	287.00	37.36				7,429.50	7,889.11	1,011.58
		Prior to transfer to present holders					.25	60,201.00	57,932.14	827.18
	6635E	Hodad	37.00	25.15				3,512.50	503.08	51.81
	6413E	Kingsmill	2,713.00	726.82				3,405.00	1,062.29	
	6487E	Leslie	305.75	53.59				846.75	460.11	1.17
	6681E	Two of a Kind	49.00	6.67				49.00	6.67	
		Sundry Claims	109.25	11.38			718.13	26,939.18	14,765.31	.20
		State Battery, Kalgoorlie		*287.43	28.93			390.70	*41,365.43	701.30

**BULONG DISTRICT.**

Bulong	G.M.L. 1338Y	Annabelle	361.72	83.83				361.72	83.83	
Morelands		Sundry Claims	7.25	3.81			.13	316.00	85.65	

Table I.—Production of Gold and Silver from all sources, etc.—continued.

Mining Centre	Number of Lease	Registered Name of Company or Lease	Total for 1970					Total Production				
			Alluvial	Dolled and Specimens	Ore treated	Gold therefrom	Silver	Alluvial	Dolled and Specimens	Ore treated	Gold therefrom	Silver
			Fine ozs.	Fine ozs.	Tons (2,240 lb.)	Fine ozs.	Fine ozs.	Fine ozs.	Fine ozs.	Tons (2,240 lb.)	Fine ozs.	Fine ozs.
<b>Coolgardie Goldfield.</b>												
<b>COOLGARDIE DISTRICT.</b>												
Bonnievale	G.M.L. 6151	Melva Maie			195.00	11.41				327.00	36.58	
	5890	Rayjax			10.75	21.12				1,136.75	1,515.11	5.12
		Sundry Claims			12.00	4.08			388.21	11,610.63	5,861.97	1.11
Bulla Bulling	6173	May Joy			25.00	9.39				25.00	9.39	
Coolgardie	(6043)	Dryden		2.26					.88	2.26		
	6167	Fly Tox			204.00	208.95				204.00	208.95	
	6158	Tindals East			19.00	3.78				19.00	3.78	
		Sundry Claims			5.00	17.15			236.14	3,044.77	90,301.94	30,193.90
Hampton Plains	P.P.L. 484, Loc. 59	T. R. Baker			62.00	4.89				108.00	11.52	
Larkinsville		Sundry Claims			2.25	10.36				147.20	528.28	1,116.50
Ryans Find	G.M.L. 5999	Consolidated Gold Mining Areas N.L.			77.00	45.15				77.00	45.15	
		Prior to transfer to present holders								241.75	2,469.56	
		State Battery, Coolgardie				*97.50			3,126.84	771.01	*43,245.84	29.28
		Powell, W. D. L.T.T. 6/70 (1823H)				*15.39					*15.39	
<b>Yilgarn Goldfield.</b>												
Bullfinch	G.M.L. 4535	Casas			23.75	8.76				84.75	57.43	2.21
Edwards Find	4548PP	Edwards Reward			54.50	9.60				54.50	9.60	
Eenuin	4540	North End			30.00	4.10				55.00	7.48	.20
Golden Valley	4427	W.A. Gold Development N.L.			426.00	372.56	4.85			3,529.10	1,111.78	45.02
		Prior to transfer to present holders							2.70	46,599.80	66,913.71	2,004.72
Hopes Hill	4576	Irene Betty			5.00	1.51	.05			5.00	1.51	.05
Marvel Loch	3724	Frances Firness			177.75	18.83			591.90	23,956.00	10,526.32	306.81
	4618	Mary Lena			767.00	284.63				767.00	284.63	
Parkers Range	4508	Buffalo			183.50	38.13			10.36	1,276.00	233.45	5.62
	4512	Constance Una			1,629.75	701.86				7,745.75	5,623.78	84.50
	4589	King of the Range			38.25	4.49				60.00	6.64	
	4621	The Dollar			30.25	11.88				30.25	11.88	
	4574	White Horseshoe			316.25	57.86				316.25	57.86	
		Sundry Claims			196.00	16.78			6.59	303.93	14,193.30	5,686.23
Southern Cross	4510	Three Boys				5.19				.50	74.88	6.03
		State Battery, Marvel Loch				*344.27	31.17			147.00	*4,892.46	2,649.45



### Dundas Goldfield.

Beete	....	G.M.L. 2044	....	Beete	....	....	....	8·85	20·00	88·73	13·35	....	178·30	82·00	156·57	51·98
Dundas	....	2054	....	Abbotshall	....	....	....	....	190·00	7·69	-18	....	....	190·00	7·69	-18
				Sundry Claims	....	....	....	....	41·00	9·59	-82	-76	413·85	2,330·75	1,177·22	21·07
Norseman	....	1936, etc.	....	Central Norseman Gold Corporation N.L.	....	....	....	....	140,634·00	48,958·67	39,711·60	....	....	4,974,938·20	2,292,010·79	1,578,773·41
				Prior to transfer to present holders	....	....	....	....	....	....	....	....	1,663·32	69,819·83	47,892·08	16,508·85
				State Battery, Norseman	....	....	....	....	....	*86·53	18·44	....	....	427·89	*26,434·38	1,153·39

### Phillips River Goldfield.

Ravensthorpe	....	M.C. 35, etc.	....	Ravensthorpe Copper Mines N.L.	....	....	....	....	....	\$729·73	1,033·71	....	....	....	\$21,583·58	64,877·91
				Prior to transfer to present holders	....	....	....	....	....	....	....	....	....	....	\$1·99	....

**TABLE II**

Production of Gold and Silver from all Sources, showing in fine ounces the output, as reported to the Mines Department during the year 1971.

Goldfield	District	District						Goldfield					
		Alluvial	Dolled and Specimens	Ore Treated	Gold Therefrom	Total Gold	Silver	Alluvial	Dolled and Specimens	Ore Treated	Gold Therefrom	Total Gold	Silver
		Fine ozs.	Fine ozs.	Tons (2,240 lb.)	Fine ozs.	Fine ozs.	Fine ozs.	Fine ozs.	Fine ozs.	Tons (2,240 lb.)	Fine ozs.	Fine ozs.	Fine ozs.
Kimberley	.....	.....	.....	.....	.....	.....	.....	.....	.....	.....	.....	.....	.....
West Kimberley	.....	.....	.....	.....	.....	.....	.....	.....	.....	.....	.....	.....	.....
West Pilbara	.....	.....	.....	.....	.....	.....	.....	.....	.....	.....	.....	.....	.....
Pilbara	Marble Bar	.....	.....	647.00	302.52	302.52	13.55	19.71	.....	.....	25.32	45.03	.....
	Nullagine	.....	.....	13.00	3.75	3.75	.....	.....	.....	660.00	306.27	306.27	13.55
Ashburton	.....	.....	.....	.....	.....	.....	.....	.....	.....	.....	.....	.....	.....
Gascoyne	.....	.....	.....	.....	.....	.....	.....	.....	.....	.....	.....	.....	.....
Peak Hill	.....	.....	.....	.....	.....	.....	.....	.....	.....	20.23	.....	20.23	.....
East Murchison	Lawlers	19.30	.....	.....	.....	.....	.....	.....	.....	.....	.....	.....	.....
	Wiluna	.....	.....	.....	.....	.....	.....	.....	.....	.....	.....	.....	.....
	Black Range	.....	.....	87.00	16.77	16.77	.....	19.30	.....	87.00	16.77	36.07	.....
Murchison	Cue	.....	.....	18.00	4.84	4.84	.....	.....	.....	.....	.....	.....	.....
	Meekatharra	.....	38.81	5,290.00	319.73	358.54	.....	.....	38.81	63,803.25	14,571.51	14,610.32	1,174.35
	Day Dawn	.....	.....	.....	.....	.....	.....	.....	.....	.....	.....	.....	.....
	Mt. Magnet	.....	.....	58,495.25	14,246.94	14,246.94	1,174.35	.....	.....	.....	.....	.....	.....
Yalgoo	.....	.....	.....	.....	.....	.....	.....	.....	.....	74.00	16.72	16.72	.....
Mt. Margaret	Mt. Morgans	.....	.....	35.00	4.95	4.95	.....	.....	.....	.....	.....	.....	.....
	Mt. Malcolm	.....	14.83	942.50	718.97	733.80	7.54	.....	14.83	977.50	723.92	738.75	7.54
	Mt. Margaret	.....	.....	.....	.....	.....	.....	.....	.....	.....	.....	.....	.....
North Coolgardie	Menzies	.....	.....	72.75	16.83	16.83	.....	.....	.....	.....	.....	.....	.....
	Ularring	.....	.....	26.75	11.10	11.10	.....	.....	.....	865.50	109.80	109.80	.....
	Niagara	.....	.....	.....	.....	.....	.....	.....	.....	.....	.....	.....	.....
	Yerilla	.....	.....	766.00	81.87	81.87	.....	.....	.....	.....	.....	.....	.....
Broad Arrow	.....	.....	.....	.....	.....	.....	.....	3.11	1.99	2,721.75	271.58	276.68	.....
North-East Coolgardie	Kanowna	.....	.....	3,755.50	306.94	306.94	.....	.....	.....	3,755.50	306.94	306.94	.....
	Kurnalpi	.....	.....	.....	.....	.....	.....	.....	.....	.....	.....	.....	.....
East Coolgardie	East Coolgardie	.....	212.72	1,456,421.00	276,110.00	276,322.22	60,942.09	.....	212.22	1,456,789.97	276,197.64	276,409.86	60,942.09
	Bulong	.....	.....	.....	.....	.....	.....	.....	.....	.....	.....	.....	.....
Coolgardie	Coolgardie	.....	2.26	612.00	449.17	451.43	.02	.....	2.26	612.00	449.17	451.43	.02
	Kunanalling	.....	.....	.....	.....	.....	.....	.....	.....	.....	.....	.....	.....
Yilgarn	.....	.....	.....	.....	.....	.....	.....	.....	.....	3,878.00	1,880.45	1,880.45	36.07
Dundas	.....	.....	.....	.....	.....	.....	.....	.....	8.85	140,885.00	49,151.21	49,160.06	39,744.39
Phillips River	.....	.....	.....	.....	.....	.....	.....	.....	.....	.....	729.73	729.73	1,033.71
South-West Mineral Field	.....	.....	.....	.....	.....	.....	.....	.....	.....	.....	.....	.....	.....
Northampton Mineral Field	.....	.....	.....	.....	.....	.....	.....	.....	.....	.....	.....	.....	.....
State Generally	.....	.....	.....	.....	.....	.....	.....	.....	.....	.....	.....	.....	.....
Outside Proclaimed Goldfield	.....	.....	.....	.....	.....	.....	.....	.....	.....	.....	.....	.....	.....
<b>Total</b>	.....	.....	.....	.....	.....	.....	.....	<b>42.12</b>	<b>299.19</b>	<b>1,875,109.47</b>	<b>344,757.03</b>	<b>345,098.34</b>	<b>102,951.72</b>

178

**TABLE III**

Return showing total production reported to the Mines Department, and respective Districts and Goldfields from whence derived, to 31st December, 1971.

Goldfield	District	District						Goldfield					
		Alluvial	Dollied and Specimens	Ore Treated	Gold Therefrom	Total Gold	Silver	Alluvial	Dollied and Specimens	Ore Treated	Gold Therefrom	Total Gold	Silver
		Fine ozs.	Fine ozs.	Tons (2,240 lb.)	Fine ozs.	Fine ozs.	Fine ozs.	Fine ozs.	Fine ozs.	Tons (2,240 lb.)	Fine ozs.	Fine ozs.	Fine ozs.
West Kimberley	....	....	....	....	....	....	....	1-30	24-68	1-00	2-49	28-47	37,317-55
Kimberley	....	....	....	....	....	....	....	9,086-26	3,035-43	22,931-90	17,292-01	29,413-70	128-76
West Pilbara	....	....	....	....	....	....	....	6,359-08	374-74	24,900-96	24,379-30	31,113-12	1,910-66
Pilbara	Marble Bar	15,530-82	4,581-71	350,009-27	337,014-09	357,126-62	33,420-51	} 26,040-35	} 7,491-40	} 500,260-94	} 472,521-29	} 506,053-04	} 34,501-43
	Nullagine	10,509-53	2,909-69	150,251-67	135,507-20	148,926-42	1,080-92						
Ashburton	....	....	....	....	....	....	....	9,268-52	482-46	6,807-10	2,913-43	12,664-41	41,971-38
Gascoyne	....	....	....	....	....	....	....	698-49	121-33	3,988-50	6,299-40	7,119-22	127-75
Peak Hill	....	....	....	....	....	....	....	3,387-79	5,434-88	783,070-73	322,738-34	331,561-01	3,794-07
East Murchison	Lawlers	7,122-81	2,362-05	2,022,688-17	827,881-22	837,366-08	27,268-77	} 9,032-39	} 22,226-13	} 12,629,009-08	} 3,655,924-39	} 3,687,182-91	} 60,324-41
	Wiluna	236-48	1,254-11	8,873,653-69	1,872,323-07	1,873,813-66	10,322-32						
	Black Range	1,673-10	18,609-97	1,732,667-22	955,720-10	976,003-17	22,733-32						
Murchison	Cue	5,145-34	9,109-95	6,815,630-31	1,403,613-40	1,417,868-69	274,844-04	} 25,789-49	} 59,689-54	} 15,360,310-43	} 6,021,090-17	} 6,106,569-20	} 522,022-32
	Meekatharra	14,705-91	18,758-87	2,334,169-57	1,312,093-82	1,345,558-60	5,278-85						
	Day Dawn	3,291-61	11,341-80	2,037,710-13	1,375,648-23	1,390,281-64	169,447-42						
	Mt. Magnet	2,646-63	20,478-92	4,172,800-42	1,929,734-72	1,952,860-27	72,452-01						
Yalgoo	....	....	....	....	....	....	....	1,815-77	3,263-38	444,960-08	264,393-31	269,472-46	1,523-06
Mt. Margaret	Mt. Morgans	3,574-87	9,401-98	1,218,186-31	718,019-63	730,996-48	5,831-33	} 11,790-63	} 35,467-19	} 11,506,215-32	} 4,967,388-77	} 5,014,646-59	} 262,843-92
	Mt. Malcolm	4,067-66	16,710-86	7,759,855-77	3,075,325-58	3,096,104-10	190,821-89						
	Mt. Margaret	4,148-10	9,354-35	2,528,173-24	1,174,043-56	1,187,546-01	66,190-70						
North Coolgardie	Menzies	1,696-69	7,039-71	1,954,836-23	1,434,078-10	1,442,814-50	39,179-65	} 4,858-70	} 19,978-13	} 3,737,641-48	} 2,589,081-71	} 2,613,918-54	} 72,529-03
	Ularring	129-66	7,299-53	539,222-45	447,570-08	454,999-27	22,286-97						
	Niagara	1,718-48	1,821-77	944,525-02	528,605-23	532,145-48	5,716-17						
	Yerilla	1,313-87	3,817-12	299,057-78	178,828-30	183,959-29	5,346-24						
Broad Arrow	....	....	....	....	....	....	....	22,002-94	28,152-94	1,421,216-24	755,385-00	805,540-88	5,703-32
North-East Coolgardie	Kanowna	106,549-25	13,635-61	1,038,041-86	631,353-51	751,538-37	3,051-22	} 119,386-73	} 21,942-62	} 1,052,880-68	} 650,599-19	} 791,928-54	} 3,063-93
	Kurnalpi	12,837-48	8,307-01	14,838-82	19,245-68	40,390-17	12-71						
East Coolgardie	East Coolgardie	33,741-51	41,472-41	98,933,521-24	38,667,257-29	38,742,471-21	6,491,084-02	} 61,147-04	} 57,509-18	} 99,122,499-79	} 38,800,530-55	} 38,919,186-77	} 6,491,183-78
	Bulong	27,405-53	16,036-77	188,978-55	133,273-26	176,715-56	99-76						
Coolgardie	Coolgardie	17,212-95	22,154-31	3,018,754-97	1,549,027-71	1,588,394-97	54,478-99	} 18,734-84	} 28,038-13	} 3,387,149-92	} 1,803,062-38	} 1,849,835-35	} 55,252-05
	Kunanalling	1,521-89	5,883-82	368,394-95	254,034-67	261,440-38	773-06						
Yilgarn	....	....	....	....	....	....	....	2,198-76	6,414-14	8,300,768-22	2,447,375-56	2,455,988-46	216,511-16
Dundas	....	....	....	....	....	....	....	2,256-21	16,676-50	7,021,757-62	3,264,854-45	3,283,787-16	1,996,793-46
Phillips River	....	....	....	....	....	....	....	607-11	823-32	131,222-24	125,786-44	127,216-87	81,020-99
South-West Mineral Field	....	....	....	....	....	....	....	313-08	48-66	4,938-33	2,522-84	2,833-98	15-18
Northampton Mineral Field	....	....	....	....	....	....	....	....	....	....	....	....	5,236-31
State Generally	....	....	....	....	....	....	....	1,200-86	1,111-85	27-00	10,203-49	12,516-20	32,662-66
Outside Proclaimed Goldfield	....	....	....	....	....	....	....	....	....	....	....	....	1,259-58
<b>Total</b>	....	....	....	....	....	....	....	<b>335,976-34</b>	<b>318,306-63</b>	<b>165,462,557-56</b>	<b>66,204,343-91</b>	<b>66,858,626-88</b>	<b>9,927,746-76</b>

178

TABLE IV

Total output of Gold Bullion, Concentrates, etc., entered for export and received at the Perth Mint from 1st January, 1886.

Year	Export		Mint		Total	Estimated Value
	Fine ozs.		Fine ozs.		Fine ozs.	\$A
1886	270-17	.....	.....	.....	270-17	2,294
1887	4,359-37	.....	.....	.....	4,359-37	37,036
1888	3,124-82	.....	.....	.....	3,124-82	26,546
1889	13,859-52	.....	.....	.....	13,859-52	117,742
1890	20,402-42	.....	.....	.....	20,402-42	173,328
1891	27,116-14	.....	.....	.....	27,116-14	230,364
1892	53,271-65	.....	.....	.....	53,271-65	452,568
1893	99,202-50	.....	.....	.....	99,202-50	842,770
1894	185,298-73	.....	.....	.....	185,298-73	1,574,198
1895	207,110-20	.....	.....	.....	207,110-20	1,759,498
1896	251,618-69	.....	.....	.....	251,618-69	2,137,616
1897	603,846-44	.....	.....	.....	603,846-44	5,129,954
1898	939,489-49	.....	.....	.....	939,489-49	7,981,394
1899	1,233,360-25	.....	187,244-41	.....	1,470,604-66	12,493,464
1900	894,387-27	.....	519,923-59	.....	1,414,310-86	12,015,220
1901	923,686-96	.....	779,729-56	.....	1,703,416-52	14,471,308
1902	707,039-75	.....	1,163,997-60	.....	1,871,037-35	15,895,322
1903	833,685-78	.....	1,231,115-62	.....	2,064,801-40	17,541,438
1904	610,616-04	.....	1,172,614-03	.....	1,983,230-07	16,848,452
1905	655,089-88	.....	1,300,226-00	.....	1,955,315-88	16,611,303
1906	562,250-59	.....	1,232,296-01	.....	1,794,546-60	15,245,498
1907	431,803-14	.....	1,265,750-45	.....	1,697,553-59	14,421,500
1908	356,353-96	.....	1,291,557-17	.....	1,647,911-13	13,999,762
1909	386,370-58	.....	1,298,898-83	.....	1,595,269-41	13,552,548
1910	233,970-34	.....	1,236,661-68	.....	1,470,632-02	12,493,696
1911	160,422-28	.....	1,210,445-24	.....	1,370,867-52	11,646,150
1912	83,577-12	.....	1,199,080-87	.....	1,282,657-99	10,896,770
1913	86,255-13	.....	1,227,788-15	.....	1,314,043-28	11,163,402
1914	51,454-65	.....	1,181,522-17	.....	1,232,976-82	10,474,704
1915	17,340-47	.....	1,192,771-23	.....	1,210,111-70	10,280,456
1916	26,742-17	.....	1,034,655-87	.....	1,061,398-04	9,017,064
1917	9,022-49	.....	961,294-67	.....	970,317-16	8,243,292
1918	15,644-12	.....	860,867-03	.....	876,511-15	7,446,366
1919	6,445-89	.....	727,619-90	.....	734,065-79	7,237,018
1920	5,261-13	.....	612,581-00	.....	617,842-13	7,197,862
1921	7,170-74	.....	546,559-92	.....	553,730-66	5,885,052
1922	5,320-16	.....	532,926-12	.....	538,246-28	5,051,624
1923	5,933-82	.....	498,577-59	.....	504,511-41	4,464,372
1924	2,585-20	.....	432,449-78	.....	435,034-98	4,511,854
1925	3,910-59	.....	437,341-56	.....	441,252-15	3,748,640
1926	3,188-22	.....	434,154-98	.....	437,343-20	3,715,430
1927	3,359-10	.....	404,993-41	.....	408,352-51	3,469,144
1928	3,339-30	.....	390,069-19	.....	393,408-49	3,342,186
1929	3,037-12	.....	374,138-96	.....	377,176-08	3,204,284
1930	1,753-09	.....	415,765-00	.....	417,518-09	3,728,884
1931	1,726-66	.....	508,345-36	.....	510,072-02	5,996,274
1932	3,887-07	.....	601,674-33	.....	605,561-40	8,807,284
1933	2,446-97	.....	634,760-40	.....	637,207-37	9,772,598
1934	3,520-40	.....	647,317-95	.....	651,338-35	11,117,746
1935	9,868-71	.....	639,180-38	.....	649,049-09	11,404,298
1936	55,024-58	.....	791,183-21	.....	846,207-79	14,747,078
1937	71,646-91	.....	928,999-84	.....	1,000,646-75	17,487,510
1938	113,620-06	.....	1,064,171-13	.....	1,177,791-19	20,726,046
1939	98,739-88	.....	1,115,497-76	.....	1,214,237-64	23,685,928
1940	71,680-47	.....	1,119,801-08	.....	1,191,481-55	25,393,006
1941	65,925-94	.....	1,048,391-96	.....	1,109,317-90	23,702,890
1942	15,676-48	.....	832,503-97	.....	848,180-45	17,730,990
1943	6,408-34	.....	540,067-08	.....	546,475-42	11,421,338
1944	1,824-99	.....	464,439-76	.....	466,264-75	9,799,994
1945	5,029-38	.....	463,521-34	.....	468,550-72	10,021,082
1946	6,090-14	.....	610,873-52	.....	616,963-66	13,280,133
1947	5,220-09	.....	698,366-29	.....	703,586-38	15,151,143
1948	4,653-72	.....	600,332-07	.....	604,985-79	14,313,818
1949	4,173-14	.....	644,252-48	.....	648,425-62	15,925,616
1950	4,161-53	.....	606,171-88	.....	610,333-41	18,932,540
1951	5,589-45	.....	622,189-64	.....	627,779-09	19,450,686
1952	9,608-62	.....	720,366-44	.....	729,975-06	23,695,834
1953	5,396-30	.....	818,515-65	.....	823,911-95	26,598,184
1954	3,089-08	.....	847,451-09	.....	850,540-17	26,627,236
1955	4,091-51	.....	837,913-72	.....	842,005-23	26,351,118
1956	2,331-10	.....	810,048-68	.....	812,379-78	25,411,162
1957	2,042-27	.....	894,638-71	.....	896,680-98	23,076,370
1958	1,810-69	.....	865,376-80	.....	867,187-49	27,109,863
1959	2,321-99	.....	864,286-87	.....	866,608-86	27,083,858
1960	2,068-66	.....	858,690-02	.....	855,758-68	26,743,322
1961	2,942-58	.....	868,902-39	.....	871,844-97	27,413,780
1962	4,539-02	.....	854,829-18	.....	859,368-20	26,871,460
1963	4,665-37	.....	795,546-34	.....	800,211-71	25,035,372
1964	3,070-91	.....	709,776-09	.....	712,847-00	22,299,886
1965	2,996-56	.....	656,440-42	.....	659,436-98	20,722,164
1966	1,462-05	.....	627,314-65	.....	628,776-70	19,765,287
1967	2,743-28	.....	573,277-73	.....	576,021-01	18,071,924
1968	918-86	.....	510,784-17	.....	511,703-03	16,785,723
1969	1,413-06	.....	463,998-56	.....	465,411-62	17,707,219
1970	1,578-25	.....	340,029-82	.....	341,608-07	11,069,049
1971	938-24	.....	347,071-08	.....	348,009-32	11,921,570
		11,606,290-78	56,804,217-43		68,410,508-21	\$1,105,007,682

Estimated Mint value of above production	.....	.....	1970	1,080,609,126	1971	1,091,212,847
Overseas Gold Sales Premium distributed by Gold Producers Association, 1920-1924	.....	.....	\$A	5,179,204	\$A	5,179,204
Overseas Gold Sales Premium distributed by Gold Producers Association from 1952	.....	.....		7,297,782		8,615,631
Estimated Total	.....	.....		\$A1,093,086,112		\$A1,105,007,682
Bonus paid by Commonwealth Government under Commonwealth Bounty Act, 1930	.....	.....		322,896		322,896
Subsidy paid by Commonwealth Government under Gold Mining Industry Assistance Act, 1954, from 1955	.....	.....		26,262,838		28,086,614
Gross estimated value of gold won	.....	.....		\$A1,119,671,846		\$A1,133,417,192

**TABLE V**

*Quantity and Value of Minerals, other than Gold, Reported during the year 1971*

Number of Lease, Claim or Area	Goldfield or Mineral Field	Registered Name of Producer	Quantity Long Tons	Metallic Content	Value \$A
<b>ALUMINA</b>					
ISA	South-West	Alcoa of Australia (W.A.) Ltd.	1,255,209·00	...	80,333,200·00 (l)
<b>ASBESTOS (Chrysotile)</b>					
L.T.T. 1454H	Pilbara	Hancock L. G.	50·60	...	(b) 2,125·20
<b>BERYL (g) (h)</b>					
			BeO Units		
M.C. 27	Yalgoo	Zamen Pty. Ltd.	4·60	52·90	1,247·00
M.L. 80, etc.	Coolgardie	Australian Glass Manufacturers Co.	8·50	88·00	2,520·00
M.C. 874	Yalgoo	R. R. Taylor	40·13	461·52	11,173·47
M.C. 2163 B	East Murchison	M. A. Seivwright	·29	2·90	80·50
P.A. 2757	Yalgoo	A. Little	8·00	88·00	2,160·00
P.A. 322	Northampton	L. J. Dunn	·77	8·47	207·00
	Pilbara	Sundry Producers Moolyella	1·13	11·30	315·00
			63·42	713·09	(b) 17,702·97
<b>BUILDING STONE (Quartzite)</b>					
M.C. 1158H, etc.	South-West	House, R. P.	1,269·00	...	(c) 5,490·00
<b>BUILDING STONE (Quartz)</b>					
M.C. 2110H	South-West	Snowstone Pty. Ltd.	9,838·00	...	117,076·55 (a) (b)
<b>BUILDING STONE (Granite-facing stone)</b>					
M.C. 719H	South-West	Crawford Quarries Pty. Ltd.	638·00	...	(c) 18,016·00
<b>BUILDING STONE (Sandstone)</b>					
M.C. 1036H	South-West	Caporn, C. A.	12·00	...	72·00
M.C. 990H	South-West	Caporn, C. A.	18·00	...	108·00
			30·00	...	(a) 180·00
<b>BUILDING STONE (Spongolite)</b>					
M.C. 726H	South-West	Universal Milling Co. Pty Ltd.	8·00	...	80·00
M.C. 1062H	South-West	Worth, H.	137·00	...	1,885·00
			145·00	...	(a) (c) 1,965·00
<b>CLAYS (Bentonite)</b>					
M.C. 1042H, etc.	South-West	Scott, M. E., W. T., & R. J.	20·00	...	(a) 120·00
<b>CLAYS (White Clay—Ball Clay)</b>					
M.C. 109H	South-West	H. L. Brisbane & Wunderlich Ltd.	656·00	...	(c) 7,432·00
<b>CLAYS (Cement Clay)</b>					
M.C. 1018H	South-West	Swan Portland Cement Ltd.	5,679·23	...	5,276·40
M.C. 788H	South-West	Bell Bros. Pty. Ltd.	2,052·00	...	5,745·60
			7,731·23	...	(c) 11,022·00
<b>CLAYS (Fireclay)</b>					
M.C. 436H	South-West	Midland Brick Co. Pty Ltd.	968·00	...	484·00
M.C. 435H	South-West	Midland Brick Co. Pty Ltd.	47,440·00	...	23,720·00
M.C. 685H	South-West	Kargotich, T. J., P. & S.	4,000·00	...	3,000·00
M.C. 522H	South-West	Bridge, J. S. & T. D.	13,131·00	...	13,131·00
M.C. 1302H	South-West	Bridge, J. S.	23,962·00	...	23,962·00
	South-West	†Unspecified Producers	1,539·00	...	1,825·00
			91,040·00	...	(c) 66,122·90
<b>CLAYS (*Brick Pipe &amp; Tile Clay)</b>					
L.T.T. 1774H	Yilgarn	Nichols, R. A.	49·25	...	742·50
	South-West	†Unspecified Producers	65,372·00	...	32,804·11
			65,421·25	...	(c) 33,546·61

\* Incomplete.

† From private property not held under mining Act.

TABLE V.—Quantity and Value of Minerals, other than Gold, Reported during the Year 1971—continued

Number of Lease, Claim or Area	Goldfield or Mineral Field	Registered Name of Producer	Quantity Long Tons	Metallic Content	Value \$A
<b>COAL</b>					
C.M.L. 448, etc.	Collie	Griffin Coal Mining Co. Ltd.	611,753·94	....	2,572,231·14
C.M.L. 437 etc.	Collie	Western Collieries Ltd.	559,869·70	....	3,162,121·77
			1,171,623·64	....	5,734,352·91 (e)
<b>COBALT (Metallic By-Product Nickel Mining)</b>					
M.C. 150, etc.	Coolgardie	Western Mining Corporation Ltd.	....	Cobalt Tons 167·68	664,060·00
M.C. 39W	Broad Arrow	Great Boulder Mines Limited and North Kalgurli Mines Ltd.	....	34·75	137,500·00
			....	202·43	(f) 801,560·00
<b>COPPER (Metallic By-Product Nickel Mining)</b>					
M.C. 150, etc.	Coolgardie	Western Mining Corporation Ltd.	....	Copper Tons 939·04	(f) 998,400·00
<b>COPPER ORE &amp; CONCENTRATES (g) (h)</b>					
M.C. 35, etc.	Phillips River	Ravensthorpe Copper Mines N.L.	1,370·00	Copper Units 21,920·00	180,352·00
M.C. 68P, etc.	Peak Hill	Thaduna Copper Mines Co. Pty. Ltd.	263·54	3,036·00	26,207·00
M.C. 494	Pilbara	Baker, J. C.	7·38	135·87	528·00
M.C. 97P	Peak Hill	Group Explorations Pty. Ltd.	334·00	8,350·00	72,235·00
M.C. 94P	Peak Hill	Group Explorations Pty. Ltd.	16·00	400·00	4,000·00
			1,990·92	33,841·87	(b) 283,322·00
Gold content transferred to respective item		Also contained:	Gold	Fine ozs. 340·13	11,708·00
<b>CUPREOUS ORE AND CONCENTRATES (Fertiliser)</b>					
M.L. 416	Phillips River	Wehr, W.	30·00	Assay Cu% 8·63	2,468·32
M.C. 68P, etc.	Peak Hill	Thaduna Copper Mines	398·13	11·95	50,175·00
			428·13	11·72	(a) 52,643·32
<b>FELSPAR</b>					
M.L. 80, etc.	Coolgardie	Australian Glass Manufacturers Co.	414·50	....	(a) 6,217·50
<b>GLASS SAND</b>					
M.C. 1827H	South-West	Oma, R. C.	182·00	....	1,365·00
M.C. 417H, etc.	South-West	Australian Glass Manufacturers Co.	16,167·14	....	22,918·23
M.C. 365H	South-West	Leach, R. J.	183·00	....	556·00
M.C. 1074H	South-West	Ready Mix Concrete (W.A.) Pty. Ltd.	6,938·00	....	N.A.
M.C. 521H	South-West	Bell Bros. Pty. Ltd.	31,808·00	....	32,823·85
M.C. 1267H	South-West	Bell Bros. Pty. Ltd.	580·00	....	290·00
M.C. 619H	South-West	Westralian Sands Limited	555·00	....	1,664·00
M.C. 1191H	South-West	Silicon Quarries Pty.	116,550·00	....	23,310·40
			172,963·14	....	(c) 82,927·48
<b>GYPSUM</b>					
M.C. 30, etc.	Yilgarn	Ajax Plaster Co. Pty. Ltd.	18,295·00	....	35,799·00
M.C. 50, etc.	Yilgarn	H. B. Brady Co. Pty. Ltd.	15,663·00	....	39,157·50
M.C. 9, etc.	Yilgarn	West Australian Plaster Mills	21,530·00	....	45,213·00
M.C. 12, etc.	Dundas	McDonald & Whitfield	200·00	....	200·00
M.C. 1419H	South-West	Forsyth, V.	40·00	....	80·00
M.C. 612H, etc.	South-West	Gypsum Industries of Australia Pty. Ltd.	411·50	....	2,741·18
M.C. 485H	South-West	Swan Portland Cement	1,203·28	....	3,017·48
M.C. 43, etc.	Gascoyne	Garrick Agnew Pty. Ltd.	109,427·00	....	389,048·00
			166,769·78	....	(a) 515,256·16
Plaster of Paris reported as manufactured during the year being 35,093 tons from 49,740 tons of Gypsum by four companies.					
Gypsum used in the manufacture of cement = 14,384·28 tons.					
<b>IRON ORE (Pig Iron)</b>					
T.R. 1258H	Yilgarn	Charcoal Iron & Steel Industry	Ore Treated Tons 93,774·00	Pig Iron Recovered Tons 59,245·00	3,697,908·00 (c) (d)

TABLE V.—Quantity and Value of Minerals, other than Gold, Reported during the Year 1971—continued

Number of Lease, Claim or Area	Goldfield or Mineral Field	Registered Name of Producer	Quantity Long Tons	Metallic Content	Value \$A
<b>IRON ORE (ore Railed to Kwinana)</b>					
M.L. 2SA	Yilgarn	Dampier Mining Co. Ltd.	*1,811,523·00	Av. Assay Fe % 61·11	13,554,126·00 (n)
* Includes 541,306 W.L. Tons shipped to Eastern States and 385,509 W.L. Tons exported overseas.					
<b>IRON ORE (Ore Shipped to Eastern States)</b>					
M.L. 10, etc.	West Kimberley	Dampier Mining Co. Ltd.	1,393,994·00	65·43	9,757,958·00 (n)
M.L. 244SA	Peak Hill	Mt. Newman Mining Co. Pty. Ltd.	763,872·00	64·00	5,177,765·63 (b)
			2,157,866·00	....	14,935,723·63
<b>IRON ORE (Ore Exported Overseas)</b>					
M.L. 50, etc.	West Kimberley	Dampier Mining Co. Ltd.	2,388,331·00	Av. Assay Fe % 66·35	15,574,417·38
M.L. 10, etc.	West Kimberley	Dampier Mining Co. Ltd.	38,823·00	67·12	251,076·00
M.L. 235SA	Pilbara	Goldsworthy Mining Ltd.	6,574,008·00	63·78	49,786,984·00
M.L. 4SA	West Pilbara	Hamersley Iron Pty. Ltd.	17,763,605·71	64·16	135,762,669·00
M.L. 244SA	Peak Hill	Mt. Newman Mining Co. Pty. Ltd.	17,522,354·00	63·00	126,555,704·84
M.C. 878H	South-West	Western Mining Corporation Ltd.	663,671·00	59·97	5,166,433·00
			44,950,792·71	....	333,097,284·22 (b)
<b>IRON ORE—Pellets (Exported Overseas)</b>					
M.L. 4SA	West Pilbara	Hamersley Iron Pty. Ltd.	2,283,818·42	62·96	23,421,905·92 (b)
<b>LEAD ORE &amp; CONCENTRATES (g) (h)</b>					
M.C. 76	Northampton	Mitchell, G. H.	*40·16	Lead Tons 20·86	(b) 3,899·00
Silver content transferred to Silver item. * Contained 16·59 fine oz. Silver valued at \$23·55					
<b>* LIMESTONE (For Building, Burning Purposes, etc.)</b>					
M.C. 1662H	South-West	Bell Bros. Pty. Ltd.	37,882·00	....	30,305·60
M.C. 874H	South-West	Brambles Holdings Ltd.	14,862·00	....	7,689·20
M.C. 1290H	South-West	Caroleo, R. D. & Bellombra, V.	1,094·00	....	3,446·40
M.C. 989H	South-West	Casella, S. & M. & Ioppolo, G. J.	680·00	....	1,700·00
M.C. 1298H	South-West	Cable, D. K.	1,900·00	....	1,900·00
M.C. 1237H	South-West	Cooper Plant Hire Pty. Ltd.	7,773·00	....	3,109·00
M.C. 1826H	South-West	Essex, S. S.	150·00	....	150·00
M.C. 1596H	South-West	Hall, H. K.	3,947·00	....	986·75
M.C. 2133H	South-West	List & Sons Pty. Ltd.	4,799·00	....	2,018·60
M.C. 1386H	South-West	Marks, H. O.	68,410·00	....	34,405·00
M.C. 1105H	South-West	Moore, F. W. & E. M. Pty. Ltd.	1,434·00	....	2,868·00
M.C. 1093H	South-West	Multari, N.	72·00	....	251·20
M.C. 1284H	South-West	Panizza, P.	80,302·00	....	120,454·00
M.C. 1660H	South-West	Swan Portland Cement Ltd.	280,256·05	....	354,426·21
	South-West	†Unspecified Producers	780,725·00	....	806,083·00
			1,284,286·05	....	1,369,792·96 (c)
<b>* LIMESTONE (For Agricultural Purposes)</b>					
M.C. 50	Dundas	Esperance Lime Supply	319·00	....	3,125·00
M.C. 1220H	South-West	Steer, E. J.	75·00	....	300·00
			394·00	....	(c) 3,425·00
*Incomplete † From Private Property not held under the Mining Act.					
<b>LITHIUM ORES (Petalite) (h)</b>					
M.L. 80, etc.	Coolgardie	Australian Glass Manufacturers Co.	1,647·50	Li <sub>2</sub> O Units 6,919·50	(a) 26,189·85
<b>MAGNESITE</b>					
M.C. 76, etc.	Phillips River	Magnesite (W.A.) Pty. Ltd.	60·00	....	(b) 900·00
<b>MANGANESE (Metallurgical Grade)</b>					
M.C. 244L	Pilbara	Westralian Ores Pty. Ltd.	91,557·00	Av. Assay Mn % 46·88	1,590,513·00
M.C. 247	Pilbara	Dampier Mining Co. Ltd.	19,494·00	40·66	317,244·00
M.C. 110L, etc.	Pilbara	Dampier Mining Co. Ltd.	6,978·00	50·00	144,979·00
M.C. 24P	Peak Hill	Westralian Ores Pty. Ltd.	10,279·00	35·00	86,237·60
			128,308·00	45·01	2,138,973·60 (b)

TABLE V.—Quantity and Value of Minerals, other than Gold, Reported during the Year 1971—continued

Number of Lease, Claim or Area	Goldfield or Mineral Field	Registered Name of Producer	Quantity Long Tons	Metallic Content	Value \$A
MINERAL BEACH SANDS (Ilmenite)					
Sussex Loc. 7	South-West	Cable (1956) Ltd.	13,820.99	Av. Assay TiO <sub>2</sub> % 54.26	N.A.
M.C. 746H	South-West	Ilmenite Minerals Pty. Ltd.	81,994.79	54.33	N.A.
M.C. 389H, etc.	South-West	Western Mineral Sands Pty. Ltd.	206,106.00	54.00	N.A.
M.C. 619H, etc.	South-West	Westralian Sands Pty. Ltd.	136,659.39	56.59	N.A.
M.C. 516H, etc.	South-West	Western Titanium N.L.	241,913.90	54.55	N.A.
			680,495.07	54.76	7,940,866.11
MINERAL BEACH SANDS (Upgraded Ilmenite) (g)					
M.C. 516H, etc.	South-West	Western Titanium N.L.	10,000.00	90.10	
MINERAL BEACH SANDS (Rutile) (g) (h)					
M.C. 516H, etc.	South-West	Western Titanium N.L.	200.75	TiO <sub>2</sub> Tons 194.02	26,938.50
M.C. 619H, etc.	South-West	Westralian Sands Ltd.	18.00	15.80	2,070.00
			218.75	209.82	(b) 29,008.50
MINERAL BEACH SANDS (Leucoxene) (g) (h)					
M.C. 746H, etc.	South-West	Ilmenite Minerals Pty. Ltd.	3,173.48	TiO <sub>2</sub> Tons 2,777.69	349,785.41
Sussex Loc. 7	South-West	Cable (1956) Ltd.	1,057.82	925.89	116,594.74
M.C. 516H, etc.	South-West	Western Titanium N.L.	1,223.00	1,092.04	87,330.00
M.C. 619H, etc.	South-West	Westralian Sands Ltd.	5,482.00	4,846.45	458,294.00
			10,936.30	9,642.07	1,012,004.15 (b)
MINERAL BEACH SANDS (Monazite) (g) (h)					
M.C. 746H, etc.	South-West	Ilmenite Minerals Pty. Ltd.	30.00	ThO <sub>2</sub> Tons 210.00	4,200.00
Sussex Loc. 7	South-West	Cable (1956) Ltd.	10.00	70.00	1,400.00
M.C. 516H, etc.	South-West	Western Titanium N.L.	1,755.28	11,836.09	230,193.58
M.C. 619H, etc.	South-West	Westralian Sands Ltd.	1,295.00	8,417.50	212,082.00
			3,090.28	20,533.59	(b) 447,875.58
MINERAL BEACH SANDS (Zircon) (g) (h)					
M.C. 746H, etc.	South-West	Ilmenite Minerals Pty. Ltd.	1,196.85	ZrO <sub>2</sub> Tons 778.83	35,704.63
Sussex Loc. 7	South-West	Cable (1956) Ltd.	393.95	259.61	11,901.61
M.C. 516H, etc.	South-West	Western Titanium N.L.	8,893.85	5,846.34	216,762.00
M.C. 619H, etc.	South-West	Westralian Sands Ltd.	20,285.66	13,287.09	662,498.00
			30,775.31	20,171.87	(b) 926,866.24
MINERAL BEACH SANDS (g) (h) (Xenotime)					
M.C. 516H, etc.	South-West	Western Titanium N.L.	56.00	Y <sub>2</sub> O <sub>3</sub> lb. 29,429.12	(b) 73,920.57
NICKEL CONCENTRATES					
M.C. 39W	Coolgardie	Western Mining Corporation Ltd.	278,843.49	Av. Assay Ni% 11.49	86,219,100.00
M.L. 150, etc.	Broad Arrow	Great Boulder Mines Ltd. and North Kalgurli Mines Ltd.	19,108.72	10.91	5,681,800.00
			297,952.21	....	91,900,900.00 (c)
NICKEL ORE					
M.C. 1288, etc.	Coolgardie	Metal Exploration N.L.	82,219.17	Av. Assay Ni% 2.23	2,998,040.50 (c)
PEAT					
C.M.L. 19H	South-West	Burns, A. R.	1,284.00	....	16,012.00
			206.00	....	(c) 13,019.00
PETALITE (See Lithium Ores)					
PETROLEUM (Crude Oil)					
1H	Ashburton	West Australian Petroleum Pty. Ltd.	Barrels 16,352,920.00	....	36,466,885.73 (m)
PETROLEUM (Natural Gas)					
Lic. 1	South-West	West Australian Petroleum Pty. Ltd.	M.C.F. 1,221,221.00	....	(p) 158,758.73



TABLE V.—Quantity and Value of Minerals, other than Gold, Reported during the Year 1971—continued

Number of Lease, Claim or Area	Goldfield or Mineral Field	Registered Name of Producer	Quantity Long Tons	Metallic Content	Value \$A
<b>SALT</b>					
		State Total (Reported to Mines Department)	2,370,378·00	....	7,622,123·00 (f)
<b>SEMI PRECIOUS STONES (Amethyst)</b>					
M.C. 444	Gascoyne	Soklich, F.	lb. 741·00	....	478·50
<b>SEMI PRECIOUS STONES (Moss Opal)</b>					
M.C. 60	Dundas	Soklich, F.	lb. 77,686·00	....	13,000·10
<b>SEMI PRECIOUS STONES (Chalcedony)</b>					
M.C. 498	Gascoyne	Soklich, F.	lb. 51,437·00	....	12,105·80
<b>SEMI PRECIOUS STONES (Chrysoprase)</b>					
M.C. 5 OP	Outside Proclaimed	Wingelinna Nickel Aust. Ltd.	lb. 102,636·00	....	48,277·00
M.C. 5 OP	Outside Proclaimed	Cronulla Minerals Pty. Ltd.	44,800·00	....	17,899·00
			147,436·00	....	65,976·00
<b>SILVER</b>					
		By-Product Gold Mining	Fine oz. 445,834·13	....	635,485·58
		By-Product Lead Mining	16·59	....	23·55
			445,850·72	....	635,509·13
<b>TALC</b>					
M.L. 433H	South-West	Three Springs Talc Pty. Ltd.	28,617·00	....	(b) 747,281·00
<b>TANTO COLUMBITE ORES &amp; CONCENTRATES (g) (h)</b>					
M.C. 27	Yalgoo	Zamen Pty. Ltd.	3·83	Ta <sub>2</sub> O <sub>5</sub> Units 134·18	14,409·88
M.C. 35	Yalgoo	Zamen Pty. Ltd.	·27	7·45	792·52
M.L. 657, etc.	Greenbushes	Greenbushes Tin N.L.	33·41	1,735·40	258,427·22
M.L. 647, etc.	Greenbushes	Vultan Minerals Ltd.	35·66	862·20	104,753·00
M.L. 707	Greenbushes	Austin, H. J.	·28	11·13	4,297·00
	Pilbara	Crown Lands—District Generally	·40	8·80	970·00
			73·85	2,759·16	(b) 383,649·62
<b>TIN CONCENTRATES (g) (h)</b>					
M.L. 657, etc.	Greenbushes	Greenbushes Tin N.L.	246·54	Tons 169·88	523,965·00
M.L. 647, etc.	Greenbushes	Vultan Minerals Limited	82·08	53·50	166,799·00
M.L. 707	Greenbushes	Austin & Huitson	4·86	3·32	9,591·00
D.C. 493	Pilbara	Moolyella Tin Pty. Ltd.	13·15	9·10	27,361·00
D.C. 195, etc.	Pilbara	Pilbara Tin Pty. Ltd.	294·47	210·46	630,290·00
D.C. 585	Pilbara	Edwards, M.	2·59	1·70	4,919·00
D.C. 497	Pilbara	Henderson, J. M. & Sons	2·46	1·72	5,181·00
D.C. 281, etc.	Pilbara	J. A. Johnston & Sons Pty. Ltd.	96·43	69·21	202,694·00
M.C. 1457	Pilbara	D. W. McLeod	10·99	7·83	22,901·00
M.C. 2158	Pilbara	Westos Minerals Pty. Ltd.	20·06	15·02	44,775·00
D.C. 53, etc.	Pilbara	Marshall, W. (Cooglegong Tin Pty. Ltd.)	38·48	26·97	77,793·00
	Pilbara	Crown Lands—District Generally	5·69	4·02	12,243·24
	Pilbara	Crown Lands—District Generally	13·93	9·88	29,254·00
M.C. 305 WP	West Pilbara	Yule River Mining Pty. Ltd.	16·56	11·85	36,315·00
			848·29	594·46	1,794,081·24 (b)
<b>VERMICULITE</b>					
M.C. 965	Yilgarn	Mineral By-Products Pty. Ltd.	54·10	....	(a) 324·60

REFERENCES

N.A.—Not available for publication.

(a) Est. F.O.R. value. (b) Est. F.O.B. value. (c) Value at Works. (d) Value of Mineral recovered. (e) Value at Pit-head. (f) Estimated value based on prices shown in monthly bulletins published by the Bureau of Mineral Resources. (g) Only results of shipments realised during the period under review. (h) Metallic content calculated on Assay basis. (i) Concentrates. (j) By-product of Gold Mining. (k) By-product of Tin mining. (l) Value of Alumina as computed by the Dept. of Mines based on prices for Alumina F.O.B. Jamaica. (m) Value based on the price per barrel as assessed by the Tariff Board for Barrow Island Crude Oil at Kwinana. (n) Nominal value. (o) Estimated nominal value F.O.B. based on the price of Nickel Cathodes as published from time to time in the publication "Metals Week". (p) Nominal value at well-head.

NOTE—If utilised for publication please acknowledge release from the Hon. Minister for Mines.

**TABLE VI**  
**TOTAL MINERAL OUTPUT OF WESTERN AUSTRALIA**

Recorded mineral production of the State to 31st December, 1971, showing for each mineral the progressive quantity produced and value thereof, as reported to the Department of Mines ; including Gold (Mint and Export) as from 1886, and Other Minerals as from commencement of such records in 1899.

Mineral	Quantity	Value
		\$A
Abrasive Silica Stone ....	1.50	18.00
Alumina (From Bauxite) ....	4,359,596.00	275,351,240.00
Alunite (Crude Potash) ....	9,073.05	431,729.44
Antimony Concentrates (a) ....	9,829.69	484,994.00
Arsenic (a) ....	38,674.08	1,494,410.00
Asbestos—		
Anthophyllite ....	509.35	13,547.42
Chrysotile ....	11,239.38	989,397.40
Crocidolite ....	152,466.74	33,496,644.98
Tremolite ....	1.00	50.00
Barytes ....	8,800.20	125,551.90
Bauxite (Crude Ore) (g) ....	36,741.00	187,069.50
Beryl ....	3,735.38	973,051.91
Bismuth ....	16,259.70	14,495.67
Building Stone (g)—		
Chrysotile—Serpentine ....	4.45	106.00
Granite (Facing Stone) ....	982.00	33,504.00
Lepidolite ....	8.35	146.00
Prase ....	9.50	275.00
Quartz (Dead White) ....	1,592.23	33,914.00
Quartz ....	15,041.23	183,051.55
Quartzite ....	8,018.00	35,089.00
Sandstone ....	654.00	3,924.00
Sandstone (Donnybrook) ....	83.00	3,486.00
Slate ....	235.00	2,115.00
Spongolite ....	3,617.00	39,499.00
Tripolite ....	264.00	264.00
Calcite ....	5.00	50.00
Chromite ....	14,419.05	416,593.50
Clays—		
Bentonite ....	12,074.83	77,224.52
Brick, Pipe and Tile Clays (g) ....	767,175.95	1,195,314.16
Cement Clays ....	412,609.42	693,647.95
Fireclay ....	953,729.16	1,302,124.31
Fullers Earth ....	459.40	3,821.00
White Clay—		
Ball Clay ....	28,080.60	187,273.60
Kaolin ....	6,408.99	24,739.97
Coal ....	41,515,561.43	137,600,937.71
Cobalt (Metallic By-Product Nickel Mining) ....	712.54	2,254,485.00
Copper (Metallic By-Product Nickel Mining) ....	4,683.52	4,028,738.00
Copper (Metallic By-Product) (a) ....	(i) 191.50	65,375.10
Copper Ore and Concentrates ....	307,414.72	10,528,236.03
Corundum ....	63.15	1,310.00
Cupreous Ore and Concentrates (Fertiliser) ....	87,120.72	3,311,561.30
Diamonds ....	(e) .....	48.00
Diatomaceous Earth (Calcined) ....	520.00	15,991.00
Dolomite ....	3,046.82	26,118.20
Emeralds (cut and rough) ....	18,799.68	4,642.00
Emery ....	21.15	750.00
Felspar ....	71,385.11	535,977.56
Fergusonite ....	.30	782.80
Gadolinite ....	1.00	224.00
Glass Sand ....	534,029.75	(g) 378,862.50
Glauconite ....	(h) 6,467.00	(f) 300,769.00
Gold (Mint and Export) ....	68,410,508.21	1,105,007,682.00
Graphite ....	153.20	2,608.40
Gypsum ....	1,420,406.76	3,314,658.13
Iron Ore—		
Pig Iron Recovered ....	787,576.08	38,519,407.12
Ore Exported ....	148,740,030.18	1,023,911,590.38
Pellets Exported ....	6,985,515.49	72,330,615.47
Locally used Ore ....	6,192,743.00	30,861,936.00
For Flux ....	58,064.35	74,096.00
Jarosite ....	9.54	75.00
Kyanite ....	4,215.69	43,562.00
Lead Ores and Concentrates ....	481,841.25	10,618,881.56
Limestone (g) ....	6,825,762.17	7,145,565.57
Lithium Ores—		
Petalite ....	6,642.48	103,869.95
Spodumene ....	106.58	3,627.20
Magnetite ....	30,825.64	334,972.86
Manganese—		
Metallurgical Grade ....	1,744,036.56	38,895,620.08
Battery Grade ....	2,218.25	90,860.20
Low Grade ....	5,054.36	81,538.20
Mica ....	32,930.00	7,968.48

TABLE VI.—Total Mineral Output of Western Australia—continued

Mineral	Quantity	Value
		\$A
Mineral Beach Sands—		
Ilmenite Concentrates .... .. tons	4,792,948·69	48,416,848·32
Monazite Concentrates .... .. "	21,281·80	2,480,172·51
Rutile .... .. "	9,937·67	733,380·06
Leucoxene .... .. "	35,865·75	2,184,203·64
Zircon .... .. "	274,943·64	7,750,678·18
Xenotime .... .. "	123·00	153,323·58
Crude Concentrates (Mixed) .... .. "	155·95	1,553·00
Molybdenite .... .. "	77·50	1,730·00
Nickel Concentrates .... .. "	678,564·80	204,352,714·00
Nickel Ore .... .. "	122,335·22	4,890,920·11
Ochre—		
Red .... .. "	11,560·93	237,847·25
Yellow .... .. "	447·60	5,955·50
Peat .... .. "	3,987·55	62,633·00
Petroleum (Crude Oil) .... .. bbls.	61,445,746·00	187,155,362·73
(Natural Gas) .... .. m.c.f.	1,221,221·00	(l) 158,753·73
Palladium (By-Product Nickel Mining) .... .. troy ozs.	320·75	9,656·00
Platinum (By-Product Nickel Mining) .... .. "	1,921·87	192,385·00
Phosphatic Guano .... .. tons	11,857·06	145,420·90
Pyrites Ore and Concentrates (For Sulphur) (b) .... .. "	1,353,268·24	16,309,423·52
Quartz Grit .... .. "	829·50	1,400·70
Salt .... .. "	4,769,143·62	15,997,699·00
Semi-Precious Stones—		
Amethyst .... .. lb.	42,159·90	16,184·79
Beryl (Coloured) .... .. "	200·00	100·00
Chalcedony .... .. "	116,857·00	20,105·80
Chrysoprase .... .. "	226,289·00	103,986·00
Dravite .... .. "	19,048·00	15,593·78
Moss Opal .... .. "	81,967·00	13,741·60
Opaline .... .. "	25·00	7·50
Prase .... .. "	8,720·00	729·50
Tiger Eye Opal .... .. "	120·00	194·00
Topaz (Blue) .... .. "	7·00	3·50
Sillimanite .... .. tons	2·00	26·00
Silver (c) .... .. fine ozs.	13,279,901·46	8,420,442·28
Soapstone .... .. tons	565·40	3,855·70
Talc .... .. "	193,178·21	4,719,451·65
Tanto/Columbite Ores and Concentrates .... .. "	1,410·13	2,544,128·84
Tin .... .. "	27,833·40	20,813,265·76
Tungsten Ore and Concentrates—		
Scheelite .... .. "	169·18	143,424·24
Wolfram .... .. "	304·96	125,810·16
Vermiculite .... .. "	2,186·48	25,782·32
Zinc (Metallic By-Product) (d) .... .. "	2,887·75	(j)
Zinc Ore (Fertiliser) .... .. "	20·00	200·00
Total Value to 31st December, 1971 .... ..		\$3,336,411,404·73

(a) By-Product from Gold Mining.

(b) Part By-Product from Gold Mining.

(c) By-Product from Gold, Copper and Lead Mining.

(d) By-Product from Lead Mining.

(e) Quantity not recorded.

(f) Value of mineral or concentrate recovered.

(g) Incomplete.

(h) Mineral Recovered.

(i) Assayed Metallic Content.

(j) Value included in Lead Value.

(k) Based on the price assessed by the Tariff Board for Barrow Island crude oil at Kwinana.

(l) Nominal well-head value.

Footnote.—Comprehensive mineral production records maintained in the Statistical Branch of the Department of Mines show locality, producers, period, quantity, assayed or metallic content, and value of the various minerals listed above.

## TABLE VII

Showing average number of men employed above and below ground in the larger mining companies operating in Western Australia during 1970 and 1971.†

Company	1970			1971		
	Above	Under	Total	Above	Under	Total
<b>Gold*—</b>						
Central Norseman Gold Corporation N.L. ....	127	124	251	126	100	226
Gold Mines of Kalgoorlie (Aust.) Ltd. (Boulder) ....	320	145	465	316	137	453
Hill 50 Gold Mine N.L. ....	64	51	115	64	52	116
Lake View & Star Ltd. ....	278	277	555	257	250	507
Gold Mines of Kalgoorlie (Aust.) Ltd. (Mt. Charlotte)	12	117	129	12	113	125
North Kalgurli (1912) Ltd. ....	163	172	335	143	135	278
All other operators ....	63	29	92	37	33	70
State Average ....	1,027	915	1,942	955	820	1,775
<b>Alumina (from Bauxite)—</b>						
Alcoa of Australia (W.A.) N.L. ....	1,165	....	1,165	1,374	....	1,374
<b>Coal—</b>						
Griffin Coal Mining Co. Ltd. ....	177	....	177	177	....	177
Western Collieries Ltd. ....	123	335	458	129	317	446
<b>Copper—</b>						
§Ravensthorpe Copper Mines N.L. ....	62	60	122	....	....	....
<b>Iron Ore—</b>						
Charcoal Iron & Steel ....	7	....	7	8	....	8
Dampier Mining Co. Ltd. ....	413	....	413	422	....	422
Goldsworthy Mining Ltd. ....	386	....	386	438	....	438
Hamersley Iron Pty. Ltd. ....	791	....	791	971	....	971
Mt. Newman Mining Co. Pty. Ltd. ....	494	....	494	821	....	821
Western Mining Corporation ....	92	....	92	94	....	94
<b>Mineral Beach Sands—</b>						
Cable (1956) Ltd. ....	14	....	14	14	....	14
Ilmenite Minerals Pty. Ltd. ....	95	....	95	102	....	102
Western Mineral Sands Pty. Ltd. ....	40	....	40	43	....	43
Westralian Sands Ltd. ....	62	....	62	62	....	62
Western Titanium N.L. ....	161	....	161	178	....	178
<b>Nickel—</b>						
Great Boulder Mines Limited ....	83	53	136	304	108	412
Metals Exploration N.L. ....	48	37	85	56	94	150
Western Mining Corporation ....	672	488	1,160	783	516	1,299
<b>Petroleum—Crude Oil—</b>						
West Australian Petroleum Pty. Ltd. ....	166	....	166	106	....	106
<b>Salt—</b>						
Lefroy Salt Pty. Ltd. ....	13	....	13	15	....	15
Leslie Salt Co. ....	43	....	43	47	....	47
Texada Mines Pty. Limited ....	164	....	164	197	....	197
All other minerals ....	319	7	326	336	15	351
State Total (Other than Gold) ....	5,590	980	6,570	6,677	1,050	7,727

\* For details of individual years prior to 1967—see Annual Report for 1966 or previous reports.

† Effective workers only and totally excluding non-workers for any reason whatsoever.

§ Ceased production February, 1971.